

**C. T. BRANDON.**  
**MACHINES FOR PLANING AND GROOVING WASHBOARD-LEGS.**

No. 195,204.

Patented Sept. 18, 1877.

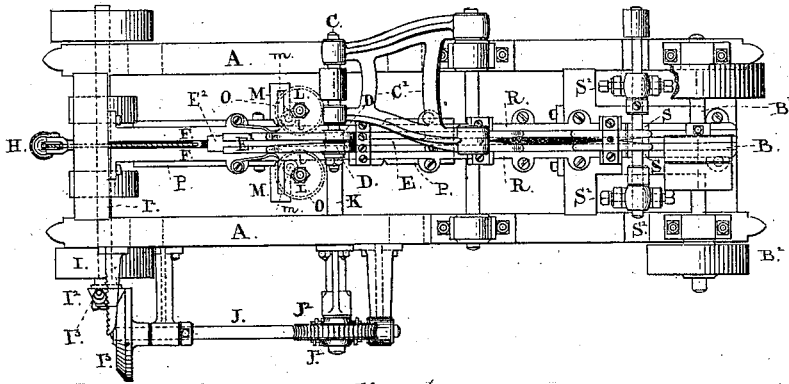

*Fig. 1.*

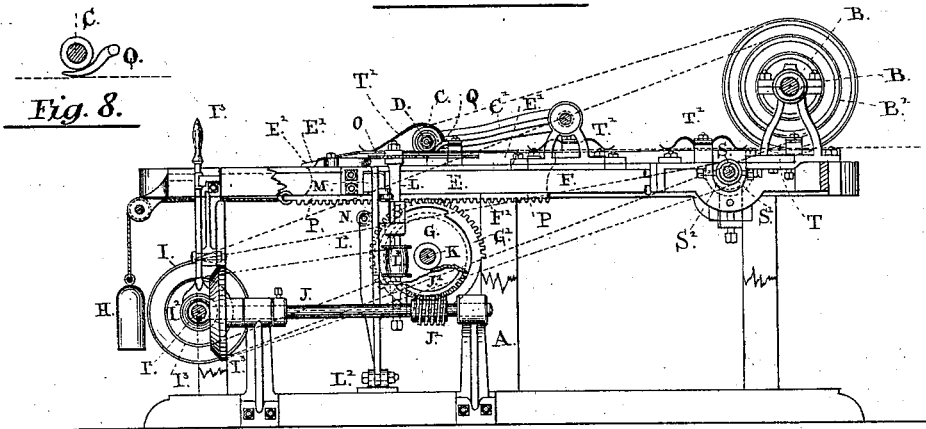

*Fig. 2.*

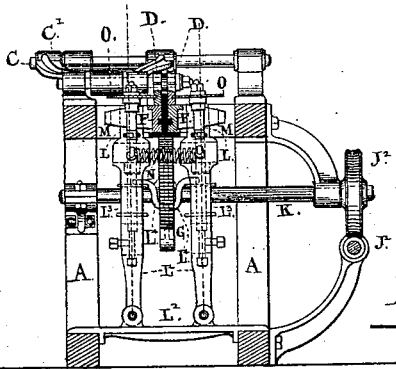

*Fig. 3.*

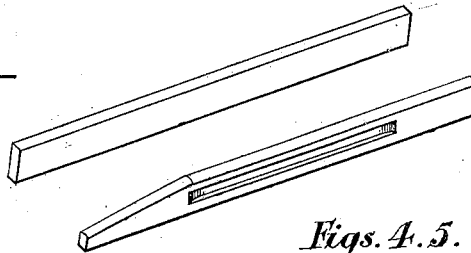

*Figs. 4 & 5.*

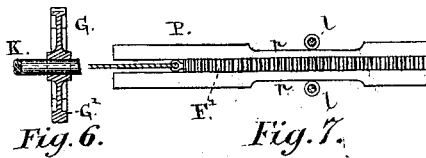

*Fig. 6.*

*Fig. 7.*

**WITNESSES:**

*H. H. Warren*  
*L. Whitehead*

**INVENTOR:**

*C. T. Brandon*  
*by Ridout & Birat Co*  
*attys*

# UNITED STATES PATENT OFFICE.

CHARLES T. BRANDON, OF TORONTO, ONTARIO, CANADA, ASSIGNOR OF ONE-HALF HIS RIGHT TO JAMES SAURIN McMURRAY AND THOMAS RICHARD FULLER, OF SAME PLACE.

## IMPROVEMENT IN MACHINES FOR PLANING AND GROOVING WASH-BOARD LEGS.

Specification forming part of Letters Patent No. 195,204, dated September 18, 1877; application filed May 22, 1877.

*To all whom it may concern:*

Be it known that I, CHARLES THOMAS BRANDON, of the city of Toronto, in the county of York, in the Province of Ontario, Canada, mechanical engineer, have invented a new and useful Wash-Board-Leg Planing and Grooving Machine; and I do hereby declare that the following is a full, clear, and exact description of the same, reference being had to the accompanying drawing, and to the letters of reference marked thereon, and forming part of this specification.

My invention has relation to a machine which is arranged to plane round, taper, and groove the legs of wash-boards at one operation, finishing the legs so perfectly that they can be used at once in the construction of wash-boards without any further hand or machine work being put upon them.

In the accompanying drawing, Figure 1 is a plan, Fig. 2 a longitudinal sectional elevation, and Fig. 3 a cross-section, of a machine constructed according to my invention. Figs. 4, 5, 6, 7, and 8 are details.

A is the frame of the machine, constructed of any durable material, arranged substantially in the manner shown. B is the driving-pulley, with loose pulley keyed to the driving-shaft B<sup>1</sup>, placed at one end of the frame. From this shaft, by means of the pulley B<sup>2</sup>, motion is communicated to the shaft C, placed near the center of the frame. This shaft C is mounted in bearings upon the end of a pivoted frame, C', in such manner that the shaft may rise and fall, as required, vertically. On the shaft C are secured two sets of planer-knives, D D, the cutting-edges of which are concave, and are, in width, left a little larger than the width of a wash-board leg. The finish these knives will give in cutting, it is evident, must be convex.

E is a traveling carriage, fitted between and supported upon a pair of metal bars, F F. This carriage, on its under face, is provided with a toothed rack, F', into which is geared a wheel, G. A portion only of the periphery of the wheel G is toothed, in order that the carriage may be moved forward a certain fixed distance only. The balance of the periphery

is cut down below the bottom of the teeth, and permits the carriage to be returned to a starting-point by the weight H. A continuous rotary motion in one direction is thus permitted to be given to the wheel G, which motion is communicated from the driving-shaft B<sup>1</sup> by the pulleys B<sup>2</sup> and I, shaft I<sup>1</sup>, friction-wheels I<sup>2</sup> and I<sup>3</sup>, shaft J, worm J<sup>1</sup>, and worm-wheel J<sup>2</sup>, and shaft K, on which shaft the wheel G is keyed. The friction-wheel I<sup>2</sup> is fitted on a feather, and is, for starting and stopping purposes, thrown in and out of gear by the lever I<sup>3</sup>.

L L are upright shafts, supported in bearings upon frames L' L', which frames are hinged at the lower end to a base-piece, L<sup>2</sup>, and at the upper end are held in slotted brackets M M, the slots *m m* in which brackets permit the shafts to be moved to and from the center of the machine, as required.

N is a spiral spring, connecting the two upright shafts controlling the movement. The shafts are driven from the shaft I<sup>1</sup> by the pulleys I<sup>2</sup> and L<sup>2</sup>. To the upper end of these shafts saws O O, of a thickness equal to the width of the groove to be cut in the leg, are fastened.

P is a form-plate, fastened to the under side of the carriage E. The edges of this plate are recessed for an interval, *p p*, equal to the length of the groove required in the wash-board leg; and the position of the former and the wash-board legs of the carriage is so arranged in relation to the saws O O that when the saws, by means of the recesses *p p*, are permitted to approach the center of the machine and cut away the wood, a groove will be formed in the legs of the length of the recess, and in a position on the legs which can never vary.

To facilitate the movement of the shafts L L in and out of the recesses *p p*, friction-rollers *l l* are fastened to the frames L' L', and the ends of the recesses are rounded; and, in order that the carriage may return freely without interfering with the saws, finger-pieces L<sup>4</sup> are attached to the frames L' and project toward the center, engaging with a filling-piece, G<sup>1</sup>, on each side of the web of

the wheel G. These filling-pieces keep the saws clear of the form on the return-stroke of the carriage.

The carriage E is provided with a midfeather, E<sup>1</sup>, projecting a suitable distance above the face of the bars F. One end of the midfeather is tapered to correspond with the required taper on the legs. On this midfeather the frame and shaft C C' are supported by the tapered bearing-block Q, in such manner that the top of the midfeather becomes a "form," to the shape of which the knives D D cut the face of the legs. The tapered end of the form finishes with a block, E<sup>2</sup>, which block engages with the ends of the legs and drives them forward.

From the shaft C to the end of the bars F raised side guide-pieces R R are fitted in the bars F, for the purpose of guiding the legs to the next or bottom planing-knives S and out of the machine.

The knives S are attached to a head on a shaft, S<sup>1</sup>, which shaft is supported in adjustable bearings S<sup>2</sup> S<sup>2</sup>, in order that the cut may be regulated, and a section, T, of the face of the bars F, beyond the shaft C, is made adjustable, being mounted on set-screws, by which the face may be raised to compensate for the thickness of the cut of the knives, and thus allow the legs to be turned out with parallel faces.

T' are springs, placed at intervals over the line of the bars F F, for the purpose of guiding and steadying the legs in their passage through the machine.

In addition to the springs, one or more rubbing-blocks may be inserted, as a further guide.

In operation, the blanks (see Fig. 4) are received of the right length and placed on the face of the bars F F in pairs, one on each side of the midfeather. The ends of the blanks are firmly pressed against the block E<sup>2</sup>, which block, when the wheel G engages with the rack of the carriage, drives them forward under and past the knives D D.

Immediately after the partly-toothed wheel G has turned the distance of its toothed face the carriage is freed, and is, by the weight H, returned to its starting-point, when the operation is repeated. During the forward progress of the carriage the saws O O are drawn inwardly at the proper interval by the spring N, cutting the side grooves. The next movement of the carriage forces the preceding pair of legs forward over the under cutting-knives, and the following movement pushes them out of the machine completed and ready to be worked into the wash-board.

It will be evident from an inspection of the drawings that, although the machine is a double machine, turning out two distinct sets, one for the right-hand and the other for the

left-hand side of the wash-board, at one operation, its capacity could be largely and cheaply increased, using the same driving-gearing throughout, by a duplication of the carriage and attachments and side saws on a slightly modified construction of frame.

I am aware that the movements of the different essential working parts of my machine could be effected by other mechanical means and motions than those given. Therefore I do not limit my claim to the exact construction shown; but

I claim as new and desire to secure by Letters Patent—

1. In combination with the horizontally-moving carriage E, provided with form E<sup>1</sup>, the pivoted frame C', provided with the rounding and tapering cutters D, arranged and operating substantially in the manner and for the purpose set forth.

2. The combination, with a horizontally-moving carriage, provided with form P, of the right and left side grooving-saws O, arranged and operating substantially as described.

3. In combination with the horizontally moving and feeding carriage E, provided with forms E<sup>1</sup> and P, the rounding and tapering cutters D, the right and left grooving-saws O, and the adjustable under-cutting-knives S, substantially as shown and described.

4. The hinged frame C', provided with the cutters D D and tapered bearing-block Q, in combination with the carriage E, provided with the form E<sup>1</sup>, substantially as shown and described.

5. In combination with the continuously-revolving partly-toothed wheel G, carriage E, with rack F' and weight H, substantially as shown and described.

6. In combination with the partly-toothed revolving wheel G, provided with the sectional filling web pieces G', the hinged frames L<sup>1</sup>, provided with the projecting finger-pieces L<sup>4</sup>, substantially as shown and described.

7. The adjustable sectional bars T, arranged to receive the legs after they have passed the knives S, substantially in the manner and for the purpose set forth.

8. The guiding and supporting bars F, in combination with the carriage E, cutters D, and saws O, substantially as shown and described.

9. The combination of the driving-shaft B<sup>1</sup>, pulleys B<sup>2</sup> and I, shaft I<sup>1</sup>, friction-wheels I<sup>2</sup> I<sup>3</sup>, shaft J, worm J<sup>1</sup>, worm-wheel J<sup>2</sup>, shaft K, and sectionally-toothed wheel G, with the carriage E, arranged and operating substantially in the manner and for the purpose set forth.

C. T. BRANDON.

Witnesses:

DONALD C. RIDOUT,  
GEO. A. AIRD.