

H. E. LIGHT.
STEAM RADIATORS.

No. 195,221.

Patented Sept. 18, 1877.

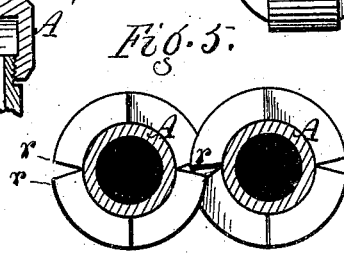
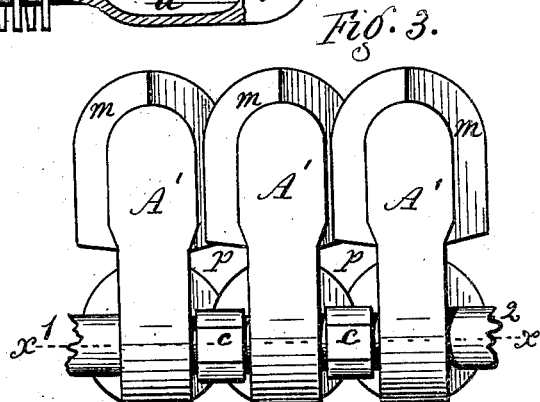
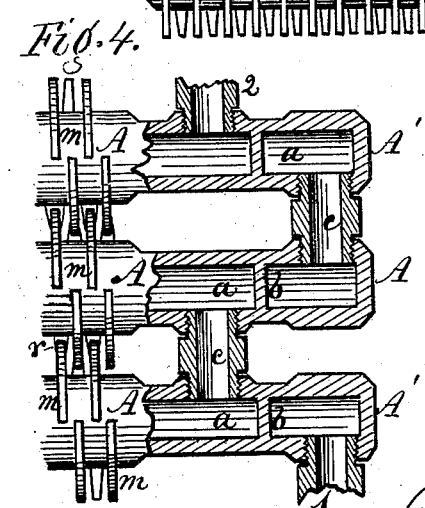
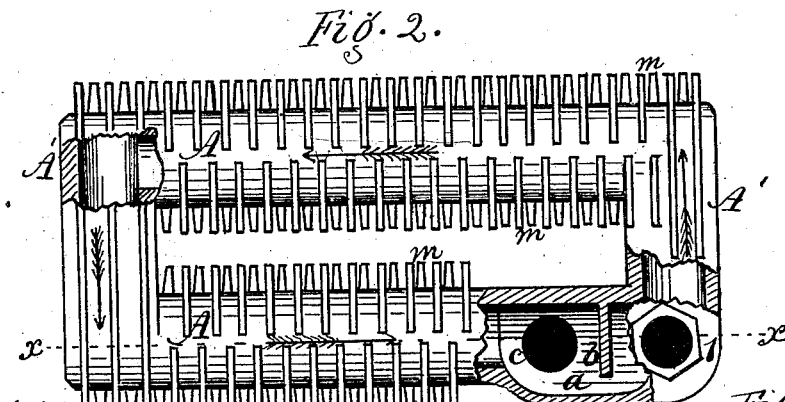
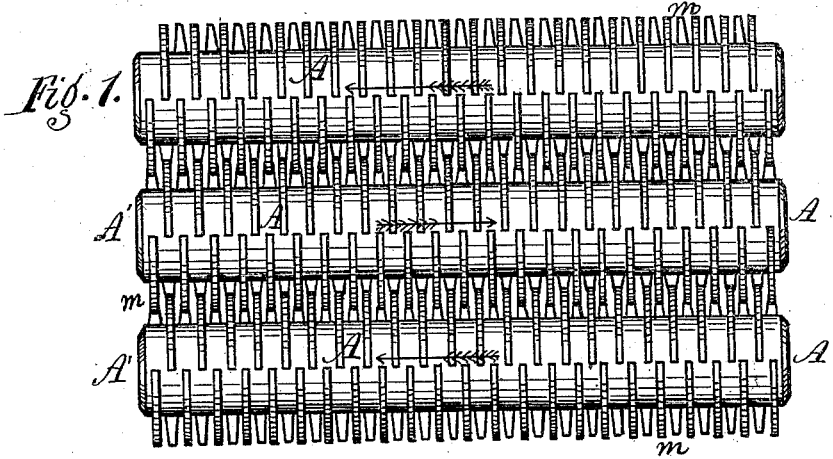

Attest.
Jacob Spahn
Louis D. Spahn

Inventor.
Harvey E. Light,
per R. L. Osgood,
Atty

UNITED STATES PATENT OFFICE.

HARVEY E. LIGHT, OF ROCHESTER, NEW YORK.

IMPROVEMENT IN STEAM-RADIATORS.

Specification forming part of Letters Patent No. **195,221**, dated September 18, 1877; application filed June 20, 1877.

To all whom it may concern:

Be it known that I, HARVEY E. LIGHT, of the city of Rochester, in the county of Monroe and State of New York, have invented a certain new and useful Improvement in Radiators; and I do hereby declare that the following is a full, clear, and exact description of the construction and operation of the same, reference being had to the accompanying drawings, in which—

Figure 1 is a plan, showing three of the radiators nested together. Fig. 2 is a side elevation. Fig. 3 is an end elevation. Fig. 4 is a horizontal section in line *xx* of Figs. 2 and 3. Fig. 5 is a cross-section of the connecting-pipes of two contiguous radiators. Fig. 6 is a view of one of the right and left threaded nipples.

My improvement relates to what is known as "pipe-radiators," used for heating by steam, and by the method known as "indirect radiation."

The invention consists in the construction and arrangement of parts, hereinafter more fully described and definitely claimed.

Each radiator is composed of two pipes, A A, and two ends, A' A', forming a circuit. The pipes are circular in cross-section, and the ends, except where connected, are circular on their edges, but flat on their sides. The diameters of the pipes and ends are the same, and, except where connected, are covered by radial flanges, as will be hereinafter described.

The radiators are used singly, or in stacks of two or more nested together, usually in basements of buildings, at an elevation from the floor, and, when so used, are sustained in their place by bars of iron set edgewise, and running crosswise underneath the radiators, one bar being set near the back side of the stack, the other just in front of the flanges or extended surfaces on the lower pipes, and in rear of the nipples connecting the radiators together. Each radiator, in its lower pipe, at one end, is constructed with flat sides, dropping down to a point below the bottom level of the passage through said pipe, forming a pocket or reservoir, *a*. Midway in the length of this pocket is a diaphragm or wing, *b*, depending from the top of the pipe, being

closed on the top and sides, and extending to a point below the passages or conduits between the several radiators, hereinafter described, but not extending to the bottom of the pocket, leaving thereby a passage under the bottom of the diaphragm from one end to the other of the pocket. This is so arranged that, the pocket holding the water of condensation, the diaphragm will form a cut-off to the circulation of the steam, forcing it to make a full circuit of one radiator before it goes into the next, also preventing the steam, when it has so made the circuit, from coming back to the place of beginning. This construction admits the water of condensation either way under the diaphragm, as may be necessary in use.

On the opposite sides of the lower pipe of each radiator, and on opposite sides of the diaphragms, and at the proper height above the bottom of the pockets, openings are cast in the pipes, the opening on one side being for the induction, and on the other for the eduction of the steam as it passes through the radiators. These openings are threaded, and in them are screwed right and left threaded nipples *cc*, which are hollow, to allow the passage of the steam. The operation of the radiators is such that the steam entering at 1 passes up, as indicated by the arrow, Fig. 2; thence horizontally through the upper pipe; thence down through the opposite end into the lower pipe; thence back through the lower pipe, whence it escapes through the hollow nipple into the next radiator, where the same circuit is made, but in the reverse direction, and from that into the third radiator, and so on, when it finally escapes through the eduction opening at 2. The water of condensation standing in the several pockets above the bottom of the diaphragms serves as cut-offs to the steam, compelling a full circuit through each radiator before escaping into the next, and at the end of each circuit preventing the steam from coming back to the point of induction, but forcing it into the next radiator. The radiators, when set in place, are so fixed that there will be an incline from the rear to the front or working end sufficient to admit of a ready escape of the waters of condensation from the

pipes to the working end, at the bottom of which it passes underneath the diaphragm either way, as may be necessary to enable it to discharge in the pipes on either side of the diaphragm connecting it to the next radiator, and so successively for the entire stack. The stack is also set at a proper incline, so that the waters of condensation will readily pass through from one radiator to another from the point of induction to the point of eduction, whence they are returned to the boiler.

pp are enlarged openings between the heads of the several radiators, formed by contracting or drawing in the lower ends of said heads to such a degree as to allow the entrance and proper working of the pipe-tongs which operate the nipples. These openings are made only at the end where the nipples are located. Were it not for these enlarged openings the tongs could not be inserted between the radiators, and the latter would have to be placed so far apart as to materially interfere with their proper action.

By constructing the radiators so that the parts containing the pockets, the diaphragms, and the inlet and outlet openings between the radiators are in the lower pipes and at the outer end thereof, and outside the bar supporting the front of the stack, I can readily get at said working ends for operating the nipples, without having to get underneath the stack, as in ordinary radiators of this class; and with the contraction in each head, (shown at *pp*, Fig. 3,) together with the proper openings between the plain faces, I am enabled to use nipples with plain faces, and of such length as to easily connect the radiators, while they can be operated by ordinary pipe-tongs, which rest in the ends in the enlarged openings *pp*. With the working-faces of the radiators made as shown, and the supporting-bar setting back of the same, as before described, the tongs can work easily on the nipples, having a swing of one hundred and twenty degrees, or more. The connection is also easily reached at any time for repairs, without having to raise the radiators from the bars or to get beneath them. I thus avoid the difficulties arising from locating the nipples midway of the radiators, in which case other devices than tongs—such as **S** wrenches—are required, the sweep being very small and the space contracted, being surrounded by the flanges, and the point of operation under the radiator.

The bodies of the radiators are covered by extended surfaces consisting of vertical flanges *mm*, which extend circumferentially around the pipes. These flanges are quadrangular, such forming a quarter of a circle, and they alternate so as to break joints as usual, resting between each other, as shown. Each space between the flanges is preferably about three-eighths of an inch wide, each flange about one-fourth of an inch wide at the base, one-sixteenth of an inch wide at the apex, and having a projection of about three-fourths of an inch. At top and bottom of

each pipe the ends of the flanges all come in line vertical to the axis, as shown in Fig. 1; but at the sides, horizontal with the axis, the points of the flanges are shortened or beveled off each one-eighth of an inch, so that the two sets will be one-fourth of an inch apart, forming thereby beveled shoulders *rr*, Fig. 5. By this means the upper flanges of one radiator rest upon the lower flanges of the next, as shown in Fig. 5, and as the radiators are drawn together or forced apart by the nipples, these flanges ride upon each other and form guides to keep the radiators in proper place.

This construction enables me to thoroughly stratify the air passing through or between the radiators, so that it shall be evenly heated, and cannot pass to the apartments above in strong gusts or unbroken columns. It also enables me to increase or decrease the size of the individual openings between the flanges, so that more or less air may pass between the flanges. The passages may be graded according to the strength of the current or to the work to be done. The adjustability of the sizes of the passages enables the radiators to be gaged to the force of the air where set or the differences in mechanical structure necessary in many instances to force air through radiators. It also enables me to form a lock-joint between the several radiators in the stack, the flanges meshing into and resting upon each other, so that no one radiator in the series can drop out of line with the others, which is often the case in radiators where the supporting-bars are too short, or get out of place, producing a water-log. The flanges are so interlocked in my invention that they can never get out of place.

The diaphragms and contiguous parts are capable of various modifications—for instance, locating them in other positions in the lower pipes.

I do not claim, broadly, radiators having flanges projecting from their surfaces; nor do I claim, broadly, pockets and diaphragms forming water-traps; neither do I claim, broadly, nipples connecting the radiators; but

I claim—

1. The radiators consisting of the pipes **A A** and ends **A' A'**, forming circuits, constructed with the enlarged openings or spaces *pp* at the front, for the purpose of inserting nipples and allowing the use of ordinary pipe-tongs for operating the nipples, without throwing the radiators too far apart, as herein shown and described.

2. In radiators such as described, the pockets *aa* and diaphragms *bb*, located at the front end of the radiators, with right and left nipples *cc* connecting the radiators on alternate sides of the diaphragms, and the enlarged openings or spaces *pp* at the ends of the radiators, the whole combined to operate in the manner and for the purpose specified.

3. In pipe-radiators such as described, the combination, with the pipes **A A**, of the

quadrangular or segment flanges *m m*, provided with the beveled shoulders *r r*, resting one upon another, as shown and described, and for the purpose specified.

4. A series of radiators each consisting of a complete pipe-circuit, provided with pockets and diaphragms forming water-traps at one end, connected by right and left nipples on opposite sides of the diaphragms, and the flanges of the several radiators interlocking or resting upon each other to prevent displacement of any one of the radiators, as shown and described, and for the purpose specified.

5. A steam-radiator section, consisting of

a complete circuit constructed with the depressed pocket *a* in the lower pipe, with a single diaphragm or wing, *b*, extending from the top of the pipe downward to the level of, or below the bottom of, the steam-passage from the radiator, as shown and described, and for the purpose specified.

In witness whereof I have hereunto signed my name in the presence of two subscribing witnesses.

HARVEY E. LIGHT.

Witnesses:

R. F. OSGOOD,

F. A. HITCHCOCK.