

T. C. CHURCHMAN.  
HORSE-POWERS.

No. 195,258

Patented Sept. 18, 1877.

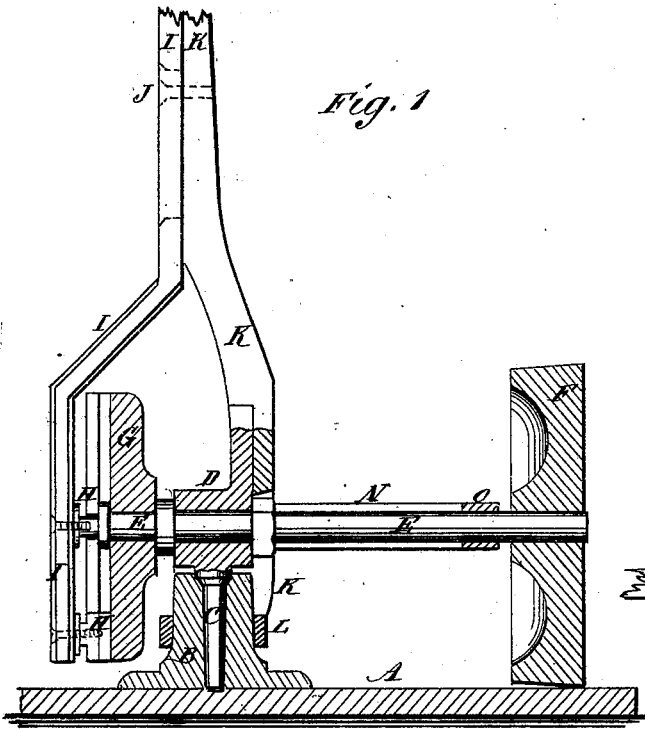

Fig. 1

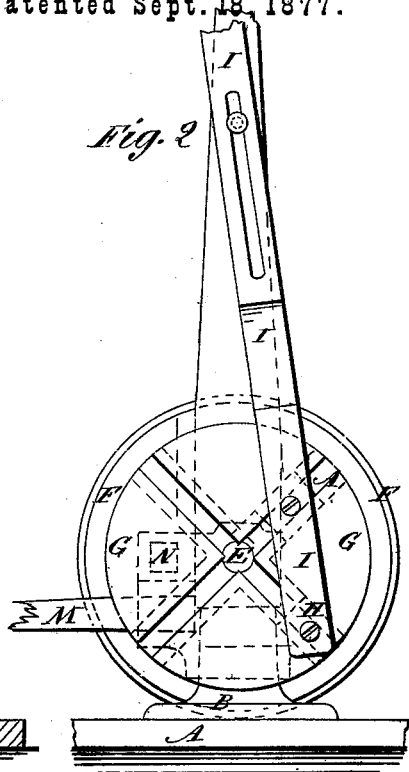
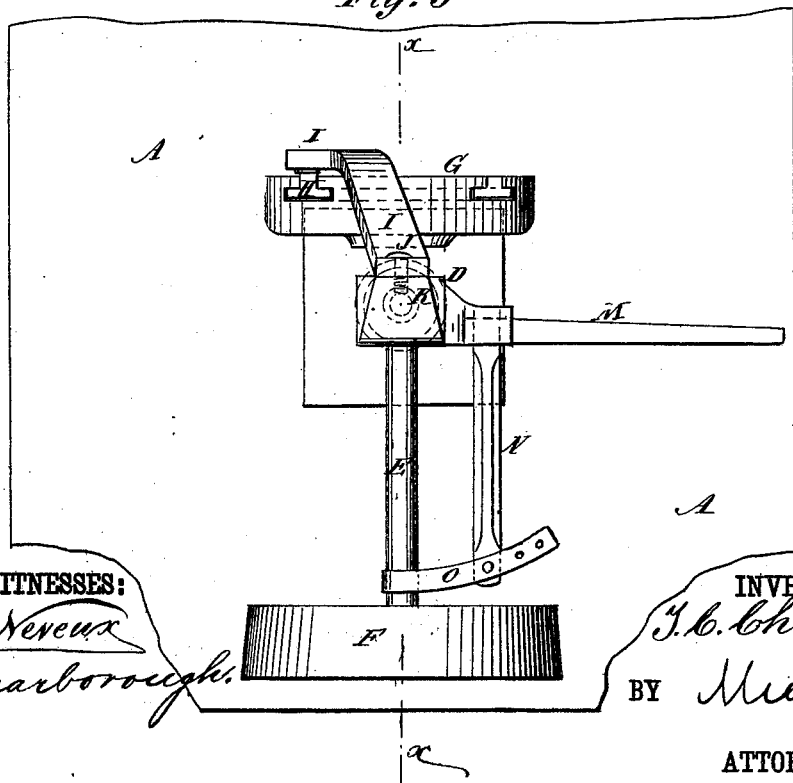

Fig. 2

Fig. 3



WITNESSES:

*C. Neveux*  
*J. Scarborough*

INVENTOR:

*T. C. Churchman*  
BY *Merrill & Co*

ATTORNEYS.

# UNITED STATES PATENT OFFICE.

THOMAS C. CHURCHMAN, OF SACRAMENTO, CALIFORNIA.

## IMPROVEMENT IN HORSE-POWERS.

Specification forming part of Letters Patent No. **195,258**, dated September 18, 1877; application filed August 3, 1877.

### *To all whom it may concern:*

Be it known that I, THOMAS C. CHURCHMAN, of Sacramento, in the county of Sacramento and State of California, have invented a new and useful Improvement in Horse-Powers, of which the following is a specification:

Figure 1 is a vertical section of my improved horse-power, taken through the line *xx*, Fig. 3. Fig. 2 is a side view of the same. Fig. 3 is a top view of the same.

Similar letters of reference indicate corresponding parts.

The object of this invention is to furnish an improved horse-power for working pumps and other machinery, which shall be so constructed as to give two motions at each revolution of the traction-wheel, which shall be free from the jerking motion which always accompanies the action of a crank, and which shall be simple in construction and convenient in use.

The invention consists in an improved horse-power, formed by the combination of the step, the spindle having a bearing or box upon its upper end, the guide-standard provided with a ring at its lower end, the grooved disk, the sliding T-blocks, and the pitman bent twice at an angle, with each other and with the shaft and the traction-wheel, as hereinafter fully described.

A represents the platform or surface upon which the machine stands and upon which the traction-wheel rolls. B is a step, in which revolves a spindle, C. To the upper end of the spindle C is attached a box or bearing, D, in which the shaft E works. To the outer end of the shaft E is attached the traction-wheel F, and to its inner end is attached a disk or wheel, G.

The disk or wheel G is made of a less diameter than the traction-wheel F, so that its rim will not come in contact with the platform A, and in its outer side are formed two T-grooves, crossing each other at right angles, and in which are placed two sliding T-blocks, H. The T-blocks H are pivoted to the pitman

I, which is bent twice at an angle, or is made with an offset, to bring its upper part directly over the spindle C.

The upper part of the pitman I is slotted to receive the guide-pin J, attached to the standard K, to keep it in proper position while moving up and down.

By this construction the pitman I will have two up-and-down movements for each revolution of the traction-wheel F, and will move steadily and without the jerking movement always produced by a crank.

The lower part of the guide-standard K is attached to the bearing D, and to its lower end, which projects downward at the side of the step B, is attached a ring, L. The ring L passes around the said step B, and keeps the guide-standard K in an erect position.

With the bearing D is also connected the lead-bar M, to which the lead-rein of the horse is attached, and the brace-bar N, the outer end of which is attached to the draft-bar O to keep the said draft-bar O in proper position. The rear end of the draft-bar O is connected with, and rides upon, the shaft E at the inner side of the traction-wheel F, and is at such a height that the draft-strain will be downward, to hold the traction-wheel F down upon the platform A and insure its revolving.

Having thus described my invention, I claim as new and desire to secure by Letters Patent—

An improved horse-power, formed by the combination of the step B, the spindle C, having a bearing, D, upon its upper end, the guide-standard K, provided with a ring, L, at its lower end, the grooved disk G, the T-blocks H, and the pitman I bent twice at an angle, as described, with the shaft E and the traction-wheel F, substantially as herein shown and described.

THOMAS CURTIS CHURCHMAN.

Witnesses:

A. C. SWEETZER,  
A. LEONARD.