

S. M. HARRIS.
WHEEL-PLOWS.

No. 195,272.

Patented Sept. 18, 1877.

Fig: 1.

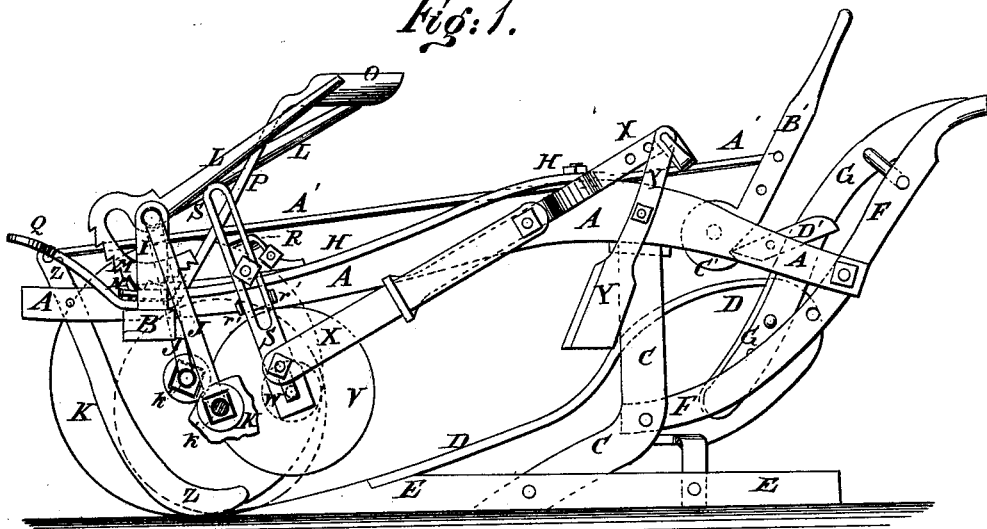

Fig: 2.

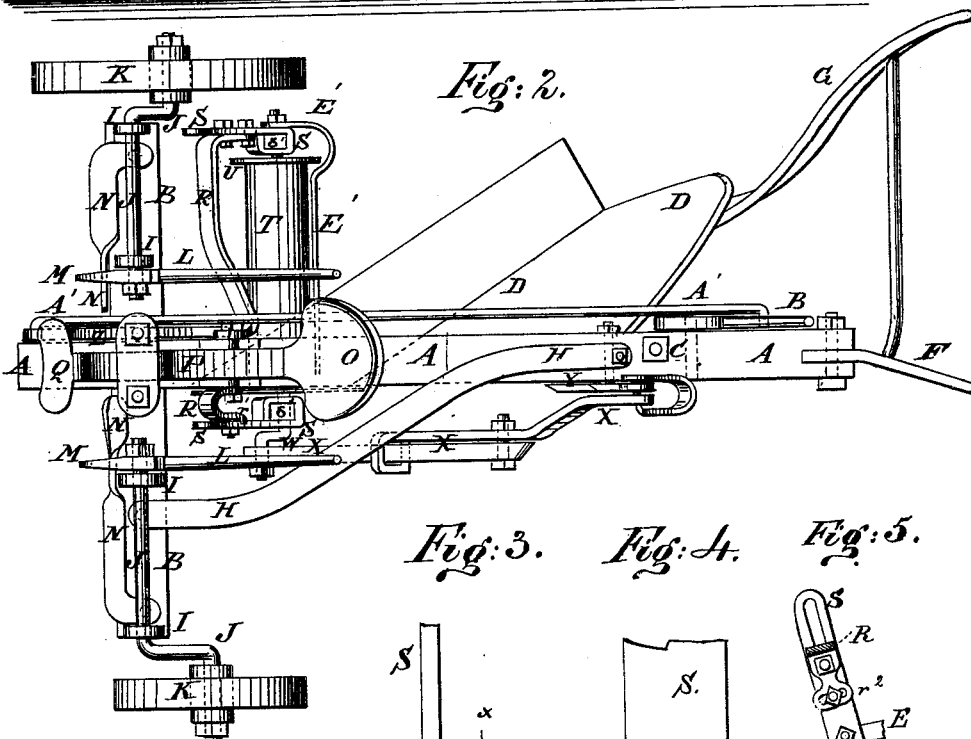
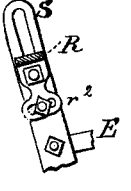
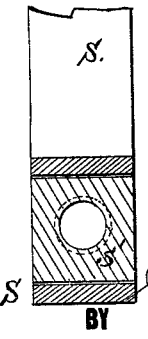
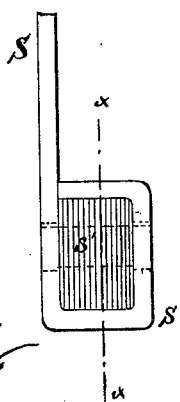

Fig: 3.

Fig: 4.

Fig: 5.



WITNESSES:

Chas. Nida
J. H. Scarborough.

INVENTOR:

S. M. Harris.

Wm. H. [Signature]

ATTORNEYS.

UNITED STATES PATENT OFFICE.

STEPHEN M. HARRIS, OF FOREST GROVE, OREGON.

IMPROVEMENT IN WHEEL-PLOWS.

Specification forming part of Letters Patent No. 195,272, dated September 18, 1877; application filed May 28, 1877.

To all whom it may concern:

Be it known that I, STEPHEN M. HARRIS, of Forest Grove, in the county of Washington and State of Oregon, have invented a new and useful Improvement in Plows, of which the following is a specification:

Figure 1 is a side view of my improved plow, part being broken away to show the construction. Fig. 2 is a top view of the same. Fig. 3 is a detail view of a bearing for the cutter and roller. Fig. 4 is a section of the same, taken through the line *x x*. Fig. 5 is a detail view of the device for adjusting the cutter to take and leave land.

Similar letters of reference indicate corresponding parts.

The object of this invention is to furnish an improved plow, which shall be so constructed that either wheel may be raised and lowered, as required; which will turn under and thoroughly cover stubble; which will clear itself of vines and weeds, and may be readily thrown out of the ground when desired.

The invention will first be described in connection with the drawing, and then pointed out in the claim.

A is the plow-beam, C is the standard, D is the mold-board, E is the land-side, F is the land-side handle, and G is the mold-board handle, about the construction of which parts there is nothing new. B is a cross-bar, which is securely clamped to the forward part of the plow-beam A and is strengthened by the brace H, one end of which is secured to the land-side part of the said cross-bar B, and its other end is secured to the plow-beam A, near its standard.

To the upper side of the end parts of the cross-bar B are attached the middle parts of U-bars I, in bearings in the ends of which work the inner arms of the crank-axles J. Upon the outer arms of the crank-axles J revolve the wheels K, which are unequal in size, the furrow-wheel being the larger.

To the inner ends of the axles J are attached levers L, upon the lower ends of which are formed segmental ratchet-wheels M. To the cross-bar B are attached spring-pawls N, in such positions as to engage with the teeth of the ratchet-wheels M, and thus hold the

wheels K securely in any position into which they may be adjusted.

O is the driver's seat, the standard P of which is attached to the beam A, and has a cross-head, Q, formed upon its upwardly-projecting end, to serve as a foot-rest. The wheels K are made of cast-iron, and are cast with square bores through their hubs, to receive square blocks *k'* of hard wood, in which are formed the bearings for the journals of the axles J. The blocks *k'*, when worn, can be readily removed and replaced with new ones.

R is a cross-bar, upon which is formed a bow, which passes around and is secured to the beam A, a little in the rear of the cross-bar B. The ends of the cross-bar R project upon the opposite sides of the beam A, and their ends are bent downward into a vertical position, and to them are bolted the upright bars S, which are slotted longitudinally to receive the fastening-bolts, so that the said bars S may be conveniently raised and lowered, as may be required.

The land-side end of the cross-bar R has lips *r'* formed upon it, which overlap the side edges of the bar S, to keep it from turning upon its bolt. The plowed-land end of the cross-bar R has a slotted cross-head, *r''*, formed upon it, to receive a bolt which passes through the slot of the bar S, so that the said bar S can be inclined forward or rearward, to adjust the cutter to take or leave land, as may be required.

In the lower ends of the bars S are formed square sockets to receive square blocks *s'*, of hard wood, in which are formed the bearings for the journals of the roller T, by which the weeds and stubble are pressed down, so that they may be covered by the furrow-slice.

To the furrow end of the roller T is attached a flange, U, which projects over the edge of the furrow, so as to bend down the projecting weeds and stubble into said furrow, and thus insure their being fully covered.

To the land-side end of the roller T is attached the cutter V, by which the sod of the furrow-slice is separated from the sod of the land. The journal of the roller T projects beyond the cutter V, and has a crank, W, formed

upon or attached to it, to which is pivoted the forward end of the connecting-rod X. The rod X is made in two parts, the adjacent parts of which overlap and are bolted to each other, so that by adjusting the said bolt the said rod may be lengthened and shortened, as desired. The rear end of the rod X has several holes formed in it to receive the bolt by which it is pivoted to the upper end of the shank of the clearer Y. Several holes are formed in the clearer Y to receive the bolt by which it is pivoted to the beam A, so that it may be adjusted higher or lower, as required. The lower part of the clearer Y passes down upon the land-side side of the standard C, and has its forward edge sharpened, so that as it swings forward it may cut off all vines, weeds, or rubbish that may collect upon the said standard and thus clog the plow.

To the forward part of the beam A is pivoted a bar, Z, the lower part of which is curved to the rearward, as shown in Fig. 1.

The roller T is kept clean by the scraper E' placed parallel with and close to its face, and the outer end of which is curved to pass around the flange U, and is bolted to the upright bar S.

To the upper end of the bar Z is pivoted the forward end of the connecting-rod A', the rear end of which is pivoted to the lever B'. The lever B' is pivoted to the plow-beam, and with its lower end are connected, or upon it are formed, ratchet-teeth C', with which engages a pawl, D', pivoted to the beam A.

The lever B' may be placed near the handles F G, or near the driver's seat O, as may be desired.

With this construction, by operating the lever B', the lower end of the bar Z may be lowered to rest and slide upon the ground, raising the forward end of the plow-beam and causing the plow to run out of the ground.

Having thus described my invention, I claim as new and desire to secure by Letters Patent—

The combination, with the crank-axles J arranged in bearings supported on cross-bar B, of the rack-levers L and spring-pawls N, as shown and described.

STEPHEN M. HARRIS.

Witnesses:

S. HUGHES,
R. T. ROBISON.