

R. HENEAGE.
 AUTOMATIC HATCHWAY-DOORS.

No. 195,276.

Patented Sept. 18, 1877.

Fig. 1.

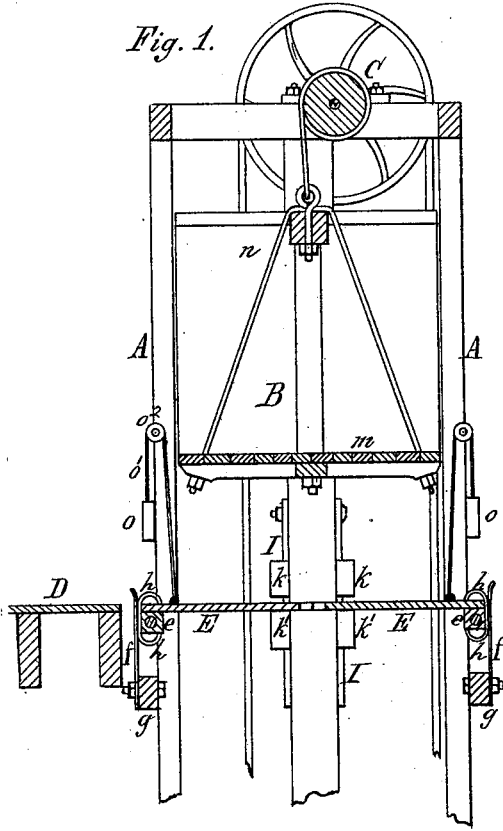

Fig. 2.

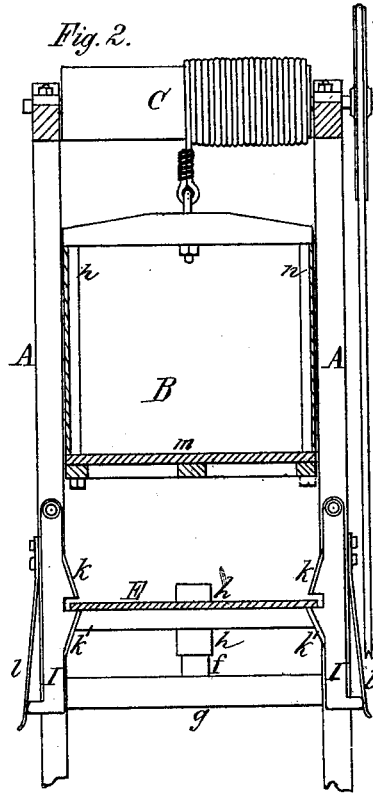

Fig. 3.

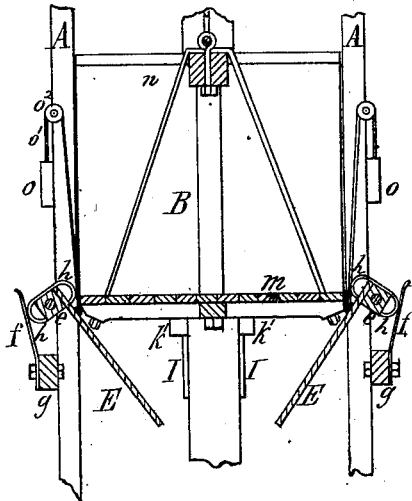
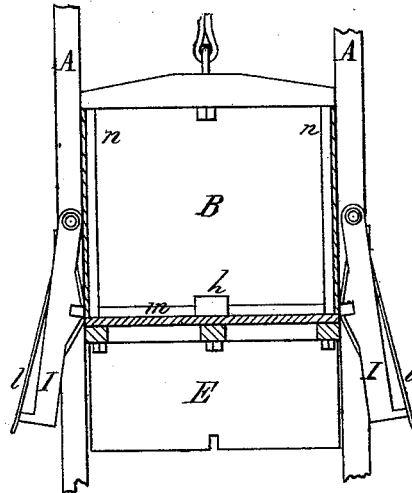

Fig. 4.



Chas. J. Buchheit.
 George H. Sykes. Witnesses

Robert Heneage, Inventor
 by Edward K. Helms, Attorney

UNITED STATES PATENT OFFICE.

ROBERT HENEAGE, OF BUFFALO, NEW YORK, ASSIGNOR OF ONE-HALF HIS RIGHT TO ALBERT C. STEVENS, OF SAME PLACE.

IMPROVEMENT IN AUTOMATIC HATCHWAY-DOORS.

Specification forming part of Letters Patent No. 195,276, dated September 18, 1877; application filed July 5, 1877.

To all whom it may concern:

Be it known that I, ROBERT HENEAGE, of the city of Buffalo, in the county of Erie and State of New York, have invented certain new and useful Improvements in Automatic Doors for Elevator-Hatchways, which improvements are fully set forth in the following specification, reference being had to the accompanying drawing.

My invention relates more particularly to that class of elevator-hatchway doors which are employed in warehouses, hotels, and other buildings for closing the hatches or openings through which the elevator cage or platform passes in the different floors, and which are provided with suitable catches for holding the door in a closed position against vertical movement in either direction, which catches are released automatically as the elevator-cage approaches the doors, so as to permit the cage to open the doors and pass through the hatch.

My invention consists of the particular construction and arrangement of the parts, as hereinafter fully set forth.

In the accompanying drawings, Figure 1 is a sectional elevation of an elevator provided with my improvements, the doors being in a closed position. Fig. 2 is a sectional elevation at right angles to Fig. 1. Fig. 3 is a sectional elevation with the doors partially open. Fig. 4 is a sectional elevation at right angles to Fig. 3.

Like letters of reference designate like parts in each of the figures.

A represents the vertical posts or guides; B, the elevator-cage, traveling between the same; C, the hoisting mechanism, and D one of the floors of the building. E E represent two horizontal doors, arranged in line with the floor D, for closing the hatchway through which the elevator-cage passes. The doors E E are hinged or pivoted at *e*, so as to swing vertically both above and below the level of the floor D. *f* is a spring, secured with its lower end to a cross-piece, *g*, of the elevator-frame, or to any other suitable support, and bearing with its free end against the outer end of each door E, which latter is provided, both on its upper and lower sides, with cams or projections *h*, arranged adjacent to the spring

f, so that the spring is strained or deflected when the door is swung out of a horizontal position in either direction, thereby giving the spring *f* a tendency to close the door. I represents spring-catches arranged on the elevator-frame, so as to support the inner ends of the doors E E, holding the latter in a horizontal position in line with the floor D. The catches I are pivoted with their upper ends to the elevator-frame, and provided with two inclines, K K', arranged, respectively, above and below the door E, and leaving a rectangular recess between the inclines, in which the door is held, as shown in Fig. 2. The catches I are held in engagement with the doors E by springs *l*.

In lowering the elevator-cage B, the floor or platform *m* thereof comes in contact with the upper inclines K of the catches I, forcing the same aside, so as to release the doors, as shown in Fig. 4. The platform *m* next comes in contact with the doors E, swinging the same downwardly and out of the way, as shown in Fig. 3, until the cage has passed through the hatchway and cleared the doors, when the latter are swung back into their horizontal position by the reaction of the springs *f*, in which position they are automatically locked by the catches I. In raising the elevator-cage the side pieces *n* of the cage come in contact with the lower inclines K' of the catches I, forcing the same aside, so as to release the doors, which latter are then swung upwardly, and returned to their horizontal position after the cage has cleared the doors, in the above-described manner.

By this means the doors are always kept closed, excepting when the elevator-cage passes through the hatchway, thereby preventing accidents, from falling through the open hatchway, and also the spreading of a fire from one story into the other, which frequently occurs from neglect to close the hatchways.

When the doors are very heavy, so as not to be easily closed by the springs *f*, they may be counterbalanced by weights *o*, connected to the doors by a rope, *o*¹, running over a sheave, *o*², or in any other suitable manner.

Having thus fully described my invention,

what I claim as new, and desire to secure by Letters Patent, is—

The combination, with the swinging hatchway-door E, provided with spring *f* and elevator-cage B, of a spring-catch lever, I, pivoted at its upper end, and provided near its lower end with a notch for holding the door, and two releasing-inclines, K K', arranged,

respectively, above and below this notch, all constructed and operating as shown and described.

ROBERT HENEAGE.

Witnesses:

EDWARD WILHELM,
CHAS. J. BUCHHEIT.