

G. M. CONOVER.
MITER-BOXES.

No. 195,347.

Patented Sept. 18, 1877.

Fig. 1.

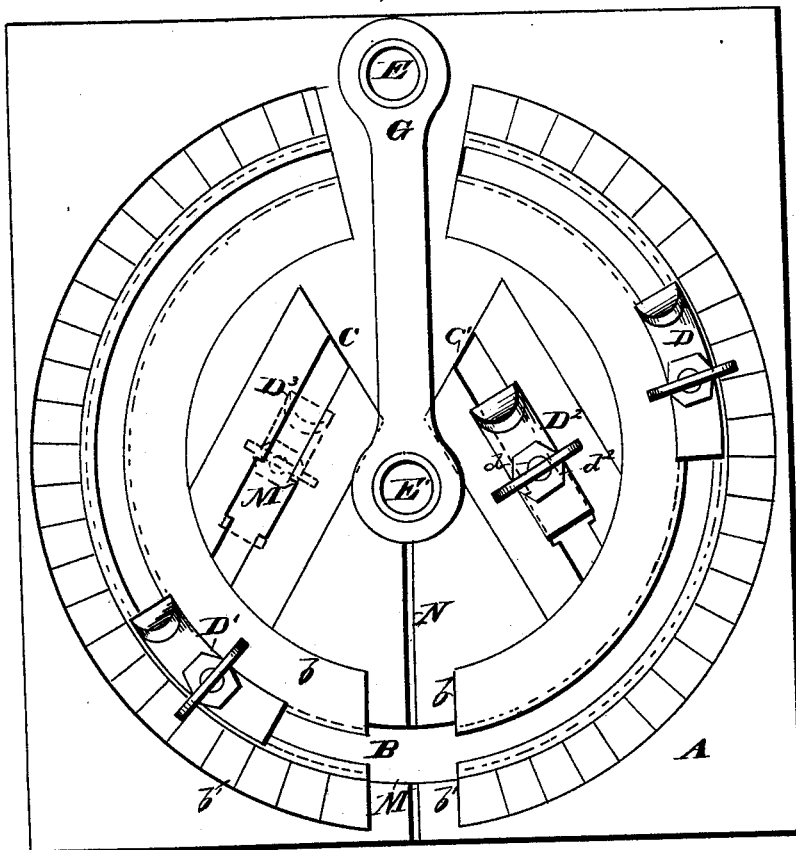

WITNESSES,
Ed. J. Nottingham.
A. Wright.

INVENTOR
George M. Conover.
By Siggelt and Siggelt
ATTORNEYS

G. M. CONOVER.
MITER-BOXES.

No. 195,347.

Patented Sept. 18, 1877.

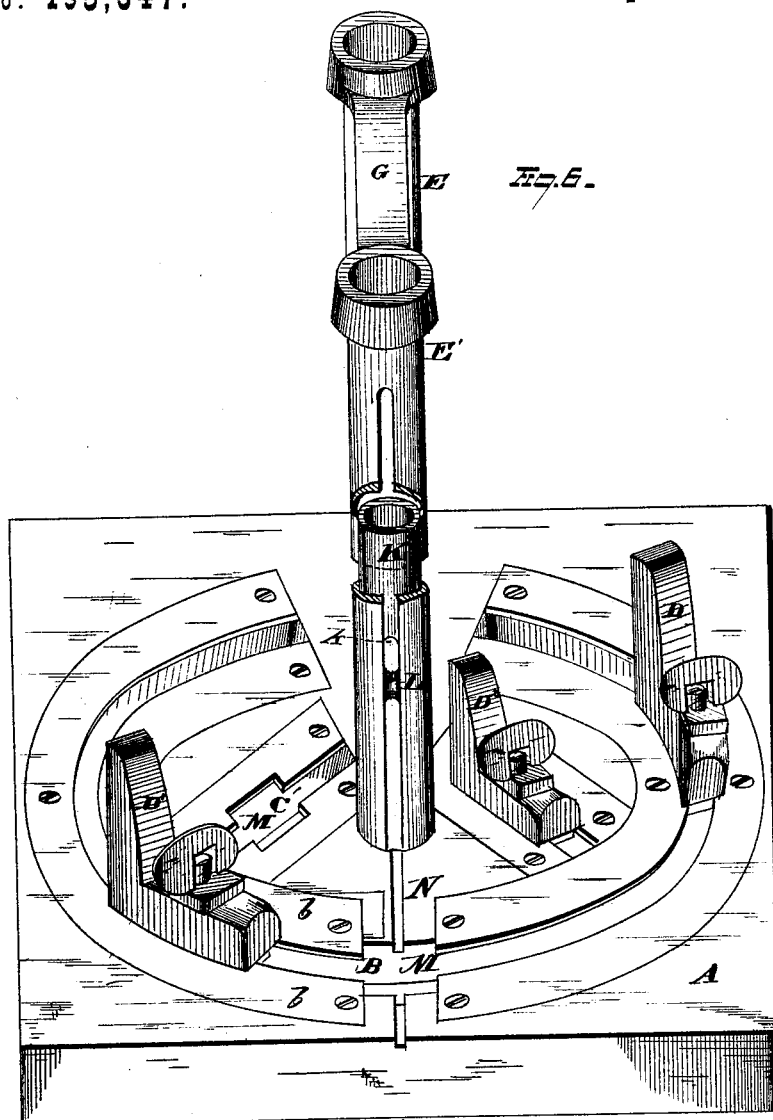

WITNESSES
C. S. Nottingham
F. O. McCleary

INVENTOR
George M. Conover,
By *Seagrett and Seagrett,*
ATTORNEYS

G. M. CONOVER.
MITER-BOXES.

No. 195,347.

Patented Sept. 18, 1877.

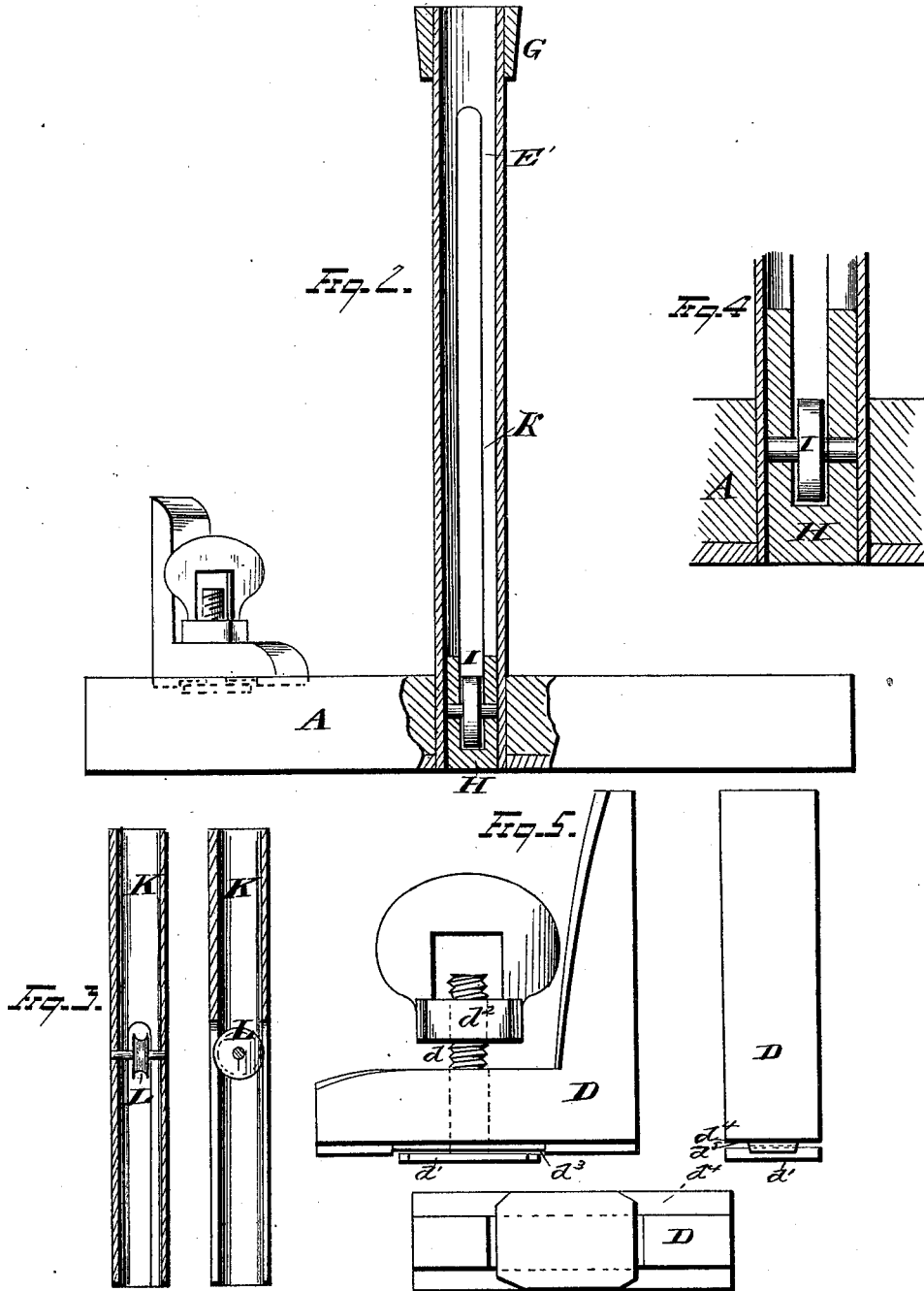

WITNESSES
Ed. J. Nottingham
A. Wright

INVENTOR
George M. Conover.
By *Segett & Segett*
ATTORNEYS

UNITED STATES PATENT OFFICE.

GEORGE M. CONOVER, OF CLEVELAND, OHIO, ASSIGNOR OF ONE-HALF HIS
RIGHT TO GEORGE R. TUTTLE, OF SAME PLACE.

IMPROVEMENT IN MITER-BOXES.

Specification forming part of Letters Patent No. 195,347, dated September 18, 1877; application filed
April 13, 1877.

To all whom it may concern:

Be it known that I, GEORGE M. CONOVER, of Cleveland, in the county of Cuyahoga and State of Ohio, have invented certain new and useful Improvements in Miter-Boxes; and I do hereby declare the following to be a full, clear, and exact description of the invention, such as will enable others skilled in the art to which it pertains to make and use it, reference being had to the accompanying drawings, which form part of this specification.

My invention relates to miter-boxes; and consists in the parts and combinations, as hereinafter specified and claimed.

In the drawing, Figure 1 represents a plan view of a miter-box embodying my invention. Fig. 2 is a side view of the same, showing one of the saw-guide supports and gages. Fig. 3 represents two sectional views of the saw-guide, taken at right angles to each other. Fig. 4 is a sectional view of the lower part of one of the saw-guide standards. Fig. 5 represents a side, end, and bottom view of one of the gages. Fig. 6 represents a view, in perspective, of my improved miter-box.

The base A of the device may be of any suitable material and form. It is provided with a circular groove, B, partly covered by the semicircular plates *b b'*. Said groove may be formed, however, in any other manner; for instance, they may be cast in any suitable metal.

The base A is further provided with the straight grooves *O O'*, similarly formed to the groove B. The outer plate *b'* has formed on it a graduated scale, by which to determine the position in which the gages D are to be placed.

E E' are the saw-guide supports or standards, which fit snugly into suitable openings in the base A, and can be readily removed therefrom when necessary. They are connected together at their upper ends by the bar G, which can also be readily detached when desired.

These standards E, represented in cross-section in Fig. 4, are of tubular form, and are each provided with two slots, opposite each other, through which the saw may pass.

In the lower portion of each standard is secured a plug or short cylinder, H, preferably constructed of wood, which carries a small wheel or roll, I, of hard rubber or soft metal, over which the saw can pass after it has cut through the wood to be mitered.

By means of this device the deepening of the groove in the base is prevented, and the teeth of the saw remain uninjured.

Within the hollow standards E are placed the tubular saw-guides K, provided with suitable slots *k* for the admission of the saw. Said slots extend from the lower end of the guides to about their middle, at which point a sheave or grooved wheel, L, is placed. Said wheel is placed on a spindle or shaft, which is journaled in the sides of the guide. The groove in the wheel may be omitted if desired.

In the drawing the wheel or sheave is represented as projecting into the slot of the guide, by which it is kept in position; but that is not essential, as the wheel might be made of smaller diameter and greater width, and, instead of the wheel revolving on its spindle, the two might be firmly secured together, and the spindle be made to revolve in its bearings. When the saw is introduced into the slots of the said guides, the back of the same bears against these wheels or sheaves L, and, as it moves forward and backward, the sheaves revolve. The saw, therefore, moves much more freely by reason of the reduction of friction, between the back of the saw and the saw-guide, to a minimum, than when the use of said wheels is dispensed with.

The vertical movement of the saw-guide is also facilitated by placing the wheel at or near the middle of the guide, by which arrangement the said guide is balanced. The pressure being only at the middle of the guide, much less friction is produced than when the pressure is to one or the other side of the middle.

If desired or necessary, the upper part of the saw-guides may be loaded by inserting therein any heavy material.

DD¹ D² are gages, which move in the grooves B C, and are provided with a clamping device by which they can be fixed at any desired

point. This clamping device consists of a screw, d , provided with a large head or plate, d^1 , and a nut, d^2 , by which the head of the screw can be brought in close contact with the projection d^3 on the under side of the gage. The inner projecting sides of the semicircular plates $b b'$ project into the space or groove d^5 formed between the head d^1 and the under side of the gage d^4 . (See Fig. 5.) The gage is firmly held in any desired place in the groove by tightening the nut d^2 , which brings the head d^1 against the plates $b b'$, and it is loosened by turning the nut in the opposite direction.

M M are enlargements or openings in the plates, through which the gages are inserted. They are constructed sufficiently large to admit the head d^1 of the gage.

The operation of the device is as follows: If the article to be cut is long enough to extend across the base A the two gages D and D¹ are shifted to the proper position and secured, as indicated in Fig. 1, so that the outside faces of the central standard E and gages D D¹ are in the same straight line. The article is then placed against the same, and the saw introduced into the slot of the standards and saw-guides. The sheaves or wheels of the guides will rest on the back of the saw, and will revolve with the movements of the same. The saw, therefore, moves with the least possible friction, and since the saw-guides are balanced, as before described, their vertical or up-and-down movement is as free as can be secured. When the article has been cut through, the saw comes in contact with the hard-rubber or soft-metal roller I, which prevents the enlargement of the cut N, and at the same time does not injure the teeth of the saw, both on account of the yielding nature of the material of the roller as well as on account of the revolution of the same. If an article is shorter than the width of the base A, or it is desired to cut the same near one of its ends, the supplementary gages D² are employed in connection with one of the gages that move in the circular groove. For instance, D² is arranged in connection with D, (see Fig. 1,) and the ar-

article is laid against the faces of the same. Any binding of the article against the central standard E' is, therefore, prevented by this supplementary gage arranged in proximity to said central standard; or D¹ may be arranged in connection with D². Either D³ or D² is used according to the direction in which the cut is to be made.

What I claim is—

1. In a miter-box, the base A, provided with a circular and practically-continuous groove, B, in combination with gages D D¹, substantially as described.

2. In a miter-box, the base A, provided with grooves B and C, in combination with gages D D¹ and supplementary gages D² D³, substantially as and for the purpose described.

3. In a miter-box, the saw-guide standards, in combination with the rollers I and blocks H, in which latter the rollers are journaled, and which extend above the surface of the rollers, and serve as a rest for the saw-guides, preventing the same from striking the rollers, substantially as and for the purpose described.

4. In a miter-box, the saw-guides provided with sheaves or wheels L, which rest on the back of the saw, substantially as and for the purpose described.

5. In a miter-box, the combination, with the tubular standards provided with rollers I, of the tubular saw-guides provided with sheaves or wheels L, substantially as and for the purpose described.

6. The combination, with the base A, provided with grooves B and C, of the tubular saw-standards E E', saw-guides K, provided with sheaves or wheels L, and gages D D¹ D² D³, substantially as and for the purpose described.

In testimony whereof I have signed my name to this specification in the presence of two subscribing witnesses.

GEORGE M. CONOVER.

Witnesses:

FRANCIS TOUMEY,
W. E. DONNELLY.