

H. HILLER.
FUSIBLE PLUGS FOR STEAM-GENERATORS.

No. 195,367.

Patented Sept. 18, 1877.

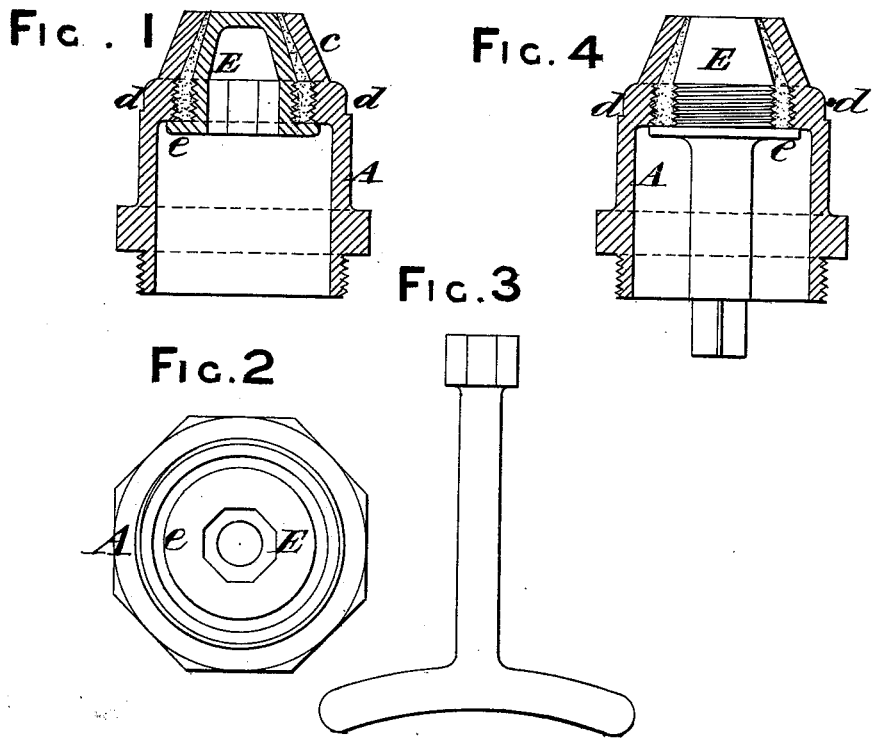

John M. Renner
Harry Smith } Witnesses

Inventor.
Henry Hiller
by his Attorneys
Howson and Son

UNITED STATES PATENT OFFICE.

HENRY HILLER, OF MANCHESTER, GREAT BRITAIN.

IMPROVEMENT IN FUSIBLE PLUGS FOR STEAM-GENERATORS.

Specification forming part of Letters Patent No. **195,367**, dated September 18, 1877; application filed July 16, 1877.

To all whom it may concern:

Be it known that I, HENRY HILLER, chief engineer of the National Boiler Insurance Company, of Manchester, in the county of Lancaster, in the Kingdom of Great Britain, have invented certain Improvements in Fusible Plugs for Steam-Generators and other apparatus, of which the following is a specification:

My invention relates to such fusible plugs as are formed with an inner cone, which is secured within an outer cone by means of an interposing stratum of fusible metal, which has hitherto been run in a melted state into the space between the two cones. When the said fusible metal has been melted, and the inner cone has thereby been released, it has been necessary to renew both cones, or to remove both cones for repairs.

The principal object of my invention is to remedy this defect, and to enable the said inner cone, in some cases, to be fixed within the outer cone, while the latter is in position, without entering the steam and water space of the boiler; and this I accomplish by so forming the parts that the inner cone, with a coating or envelope of fusible metal, can be secured within the outer cone without removing the latter from its place within the steam-generator. In certain forms of the apparatus it is necessary to enter the steam-generator to replace the part containing the fusible metal; but it is not necessary to remove the part attached to the generator. To prevent a portion of the fusible metal from being melted out in advance of the main body, I form a flange on the lower end of the inner cone.

To render my invention more clear, I have supplied a sheet of drawings marked with letters of reference.

Figure 1 represents a vertical section of one form of fusible plug as constructed in accordance with my invention. Fig. 2 is a plan of the plug reversed to show the interior. Fig. 3 is a representation of a key which may be employed to remove and replace the inner cone, and Fig. 4 a modification of the device for screwing the inner cone into position.

In Figs. 1 and 2, A is the outer cone, which is suitably formed to screw into a furnace-crown, or the part of a boiler, still, water-

heater, or similar apparatus, to which the fusible plug is to be affixed.

The upper part *c* of the outer cone is bored or formed to a conical shape, and at the base of this cone is formed a cylindrical part, *d*, which is chased, or tapped, or formed with a screw-thread on the inside. The inner cone E is made partly conical and partly cylindrical in form. The conical part is turned to a conical form, or is left rough, or is cast or formed with recesses or with flat sides. I prefer to form a screw-thread on the cylindrical part of the inner cone, and, when so formed, the conical part may be turned, and need not be formed with recesses or other means for holding the fusible metal. The base of the inner cone is formed with a flange, *e*, which is a little larger in diameter than the bore of the cylindrical part *d*.

The envelope of fusible metal is represented by the dotted space between the parts A and E. This envelope is cast upon the inner cone E, and is subsequently turned and screwed or chased to fit and screw into the outer cone A; or it may be found to be convenient to cast the envelope of fusible metal upon the said inner cone in a mold which would be constructed to impart the required form to the outside of the said envelope, and to form the screw-thread upon the cylindrical part thereof, thus dispensing with the necessity for turning the fusible metal to fit the inside of the outer cone. The envelope may be cast separate from the inner cone, and be subsequently screwed upon the inner cone, in which case the inner cone would be formed with a screw-thread, as in the drawing. It is necessary that the outer surface of the envelope shall fit the interior of the cone *c* with sufficient exactness to prevent the escape of water when the inner cone is screwed into its place within the outer cone. When so screwed into position the flange *e* covers the base of the envelope of fusible metal, and prevents the direct action of the fire upon such metal.

In the case of plugs as previously constructed, the fusible metal sometimes melts partially, so as to permit a slight escape of steam, which checks the complete fusion of the metal, and, the inner cone not being blown out, a sufficient outlet for the steam is not formed.

The flange *e* is intended to prevent any portion of the fusible metal from running out until the whole of it is fused sufficiently to permit the inner cone to be blown out, the indicated defect in the ordinary plugs being thus remedied.

The arrangements for screwing the inner cone *E* into position may be varied. For example, the said inner cone may be formed with an internal cavity, a part of which cavity is of an octagonal form, as seen in Fig. 2. A key (represented by Fig. 3) is formed to fit into the octagonal part of the said cavity.

When an inner cone has to be inserted into the outer cone *A*, it is simply necessary to place the said inner cone on the key, to insert it into the part *A*, and to screw it into position by turning the key. When an inner cone has been blown out, a fresh inner cone, or the same inner cone with a fresh envelope, can be screwed into position without emptying the boiler, it being only necessary, under ordinary circumstances, to cool the furnace sufficiently to enable an operator to get the inner cone into position, a comparatively short delay being occasioned.

The cavity in the inner cone may be made of a square, hexagonal, or other form, or slots may be cut or formed in the base, as in the case of an example to be described hereinaf-

ter. The form and proportions of the inner cone and of the cavity in which it is fixed, and the form and arrangement of the screw-thread, may be varied.

Fig. 4 illustrates a modification in the arrangements for screwing the inner cone into position. The inner cone is formed with a shank projecting into or toward the fire-box or furnace. The lower end of this shank is squared or otherwise shaped to be turned with a screw, key, or spanner.

I claim as my invention—

1. The outer cone of a fusible plug, provided with screw-threads on the inside, in combination with the inner cone and its fusible-metal envelope, adapted to be screwed into the outer cone, substantially as described.

2. The combination of the threaded outer and inner cones with the envelope of fusible metal, adapted to be screwed into the outer cone and onto the inner one.

3. The combination of the cone *E*, provided with the rectangular collar *e*, with the outer cone and the intermediate fusible metal, as and for the purpose set forth.

HENRY HILLER.

Witnesses:

J. HERBERT BROWNE,
EDWARD K. DUTTON.