

A. E. HOVEY. 2 Sheets—Sheet 1.  
 ENDLESS-ROPE TRACTION RAILWAYS.

No. 195,372.

Patented Sept. 18, 1877.

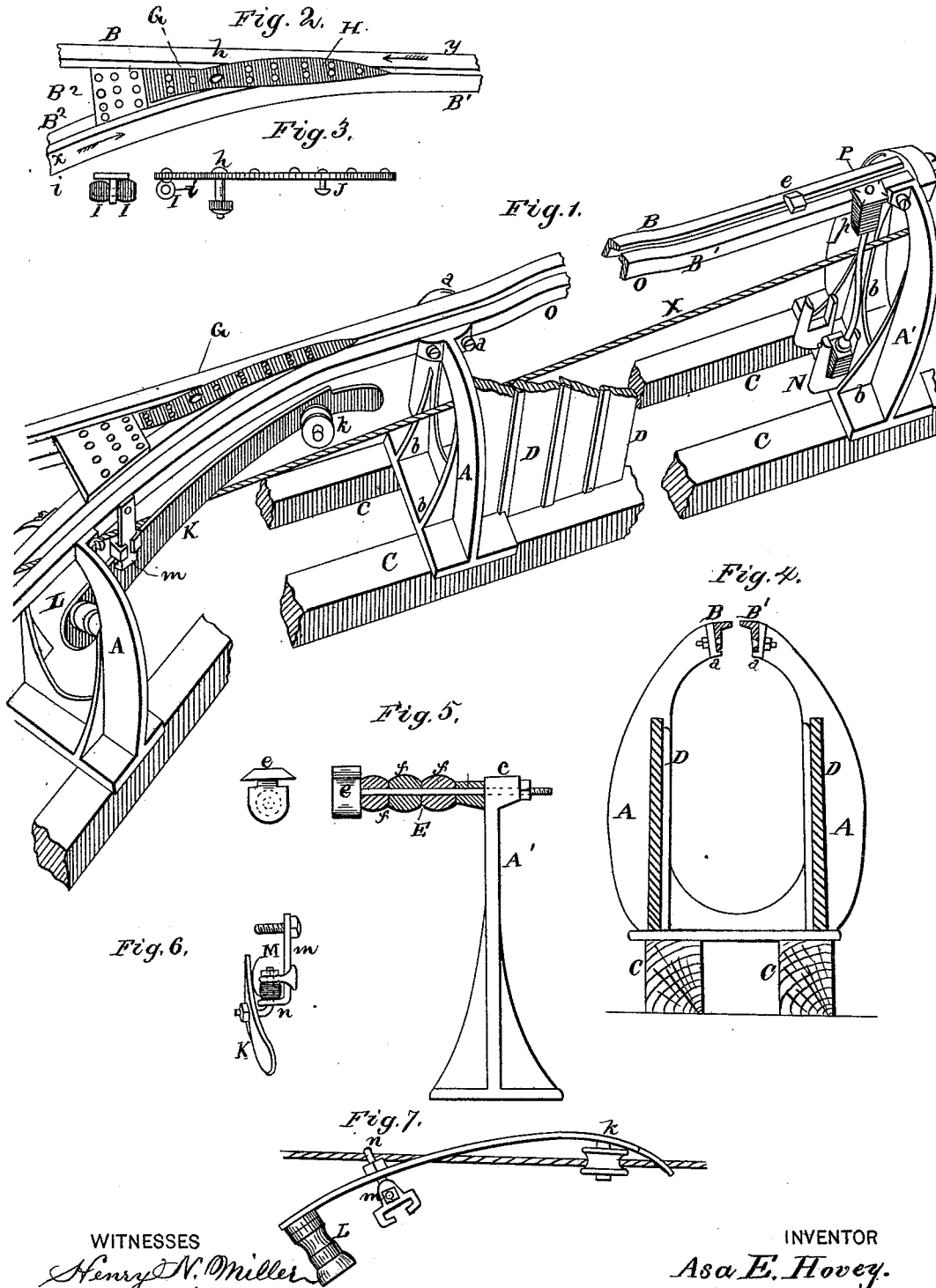

WITNESSES  
 Henry N. Miller  
 Frank L. Curraud

INVENTOR  
 Asa E. Hovey.  
 Alexander H. Mason  
 ATTORNEYS

A. E. HOVEY.  
ENDLESS-ROPE TRACTION RAILWAYS.

No. 195,372.

Patented Sept. 18, 1877.

Fig. 8.

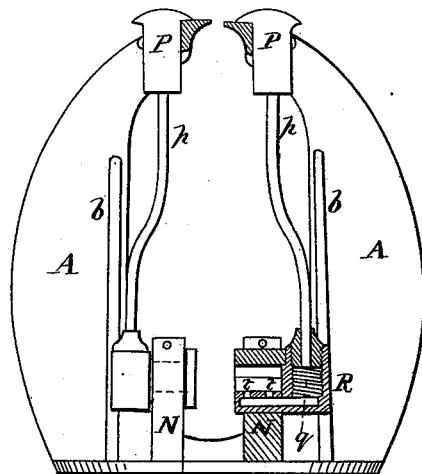

Fig. 10.

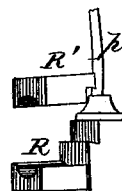
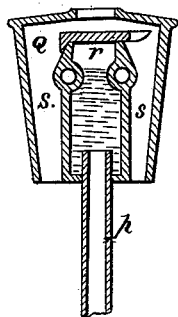

Fig. 9.



WITNESSES

*Henry N. Miller*  
*Francis L. Curaud*

INVENTOR

*Asa E. Hovey*  
*Alexander Watson*  
ATTORNEYS

# UNITED STATES PATENT OFFICE.

ASA E. HOVEY, OF SAN FRANCISCO, CALIFORNIA, ASSIGNOR TO THE SUTTER STREET RAILROAD COMPANY.

## IMPROVEMENT IN ENDLESS-ROPE TRACTION-RAILWAYS.

Specification forming part of Letters Patent No. 195,372, dated September 18, 1877; application filed October 28, 1876.

*To all whom it may concern:*

Be it known that I, ASA E. HOVEY, of the city and county of San Francisco, in the State of California, have invented certain new and useful Improvements in Endless-Rope Traction-Railways.

My invention relates to certain improvements in the construction of endless-rope traction-railways.

It consists in a novel construction of the rope chamber or tunnel, and of means for controlling the position of the rope therein; also, in a means for lubricating the rope-bearing pulleys and other operative parts from the outside of the chamber.

The object of my invention is to form a strong and permanent tunnel and road-bed, having no unprotected openings large enough to interfere with the travel in the streets, and to enable the parts to be kept lubricated without taking up and removing portions of the covering of the tunnel.

The following description of the construction and operation of my invention is sufficiently full and clear to enable any person skilled in the art to make and apply or use the same, reference being had to the accompanying drawings, and the figures and letters of reference thereon, forming part of this specification, in which—

Figure 1 is a perspective view of a portion of the frame of the tunnel and road-bed at the terminus of the groove provided for the gripping mechanism. It shows the arrangement of the groove-irons, both of the main and switch grooves, the plate or cover for protecting the opening formed by the intersection of the two grooves, the pivoted lever for depressing the rope down below the path of the gripe when the dummy is passing from the switch to the main track, and the oil-reservoir and connections with the journal-boxes of the pulleys. Fig. 2 is a plan view, and Fig. 3 a side elevation, of the self-acting groove-cover. Fig. 4 is a detail view of one of the supporting-brackets and the angle-irons that form the groove for the passage of the gripe. Fig. 5 is a side view of the bracket placed at the terminus of the groove, having the bumper

head and rod connected to it. Figs. 6 and 7 are detail views of the depressing-lever and parts supporting the same. Figs. 8 and 9 are enlarged sectional views of the oil-reservoir and of the bracket having journals of the pulleys. Fig. 10 is a detail view of the journal-boxes, showing the manner of constructing them in two parts.

A A' represent the brackets, and B B' the rails that constitute the frame or skeleton of the rope chamber or tunnel. The rails B B' are formed of angle-iron for greater strength, to resist the weight and strain from vehicles passing over them, and as affording a plane bearing-surface within and beneath the groove for the guiding-rollers in the gripe. The space or opening between the rails is left of sufficient width to allow the bar of the gripping mechanism to have a slight lateral movement within the groove, that it may pass without rubbing on the sides, any excess of movement being prevented by the contact of the guiding-rollers on the frame with the side surfaces of the angle-iron.

The brackets A A are formed with a flat bed-plate, that rests upon the supporting-sills C C, two flanges, A A, that terminate in the jaws a a, and the vertical webs b b, that give additional strength to the bracket, and afford besides a support to the plank of which the sides of the tunnel are composed.

The opening between the jaws a of the bracket is exactly in line with and over the center of the tunnel, and the angle-irons forming the rails of the groove are secured in place by means of flat-headed bolts, that enter through countersunk holes in the inner face of the rail, as shown in Fig. 4, whereby a continuous plane surface is formed for the bearing-rollers of the gripping mechanism to work against.

The form of these brackets thus gives the greatest resistance to the weight and strain thrown upon the frame in a vertical line, while it holds the rails B B' rigidly in place over the line of the tunnel. It affords a clear unobstructed space between the sides for the travel of the rope, and a broad base for sustaining the weight of the structure above.

By supporting the brackets upon the sills C C, a space between the bottom of the bracket and the bed of the tunnel is provided, affording a sewer or channel to carry off the water from the tunnel. These brackets are placed at proper intervals apart, and the sides of the tunnel are formed of planking D, laid from one bracket to another against the webs *b b*, so that the sides of the tunnel are tightly inclosed, as indicated in Fig. 1 of the drawings.

The end bracket A', that carries the bumper-rod E, has the ends of its flanges closed and joined together, and is provided with a hole through this part *c* for the rod E. The head *e* of the bumper works both above and below the groove-rails, it being made with slots of sufficient size in the sides to allow it to move freely upon the rails B B'. The rod E is provided with rubber springs *f f*, interposed between the head *e* and the bracket A', for the purpose of resisting the shock produced by the striking of the gripe-bar against the bumper when the dummy is stopped at the terminus of the road.

In this construction of a railway, where a central slot or groove in the main tracks is provided for the bar of the griping mechanism, it is necessary to have a like slot or opening in all side tracks, branches, or switches on which it is required to run the dummy, to avoid the use of large openings or traps for lifting and removing the gripe-bar, and this slot must, of course, lead from and open into the main slots or grooves at a proper angle, agreeing with the deviation of the switch or "siding" with the main tracks.

This switch or branch groove is formed by bending or curving one of the angle-irons B of the main groove from its course, and filling in the angle between the two rails B B' with a plate or angular rail, G, from which are led two rails, B<sup>2</sup> B<sup>2</sup>, of the same construction as the other rails, and with a space between them and the main rails of the same width as the groove below. Thus the principal groove is divided at this point into a main and a branch or switch groove, and by continuing this groove to the groove in the opposite track a means is provided for running the dummy from one track to another without lifting and taking out the griping mechanism. This construction is shown in Figs. 1 and 2 of the drawings.

The increased size of the opening at the angle formed by the meeting of the two grooves is protected and covered by the pivoted groove-cover H, which is arranged to be moved out of the way by the gripe-bar when the dummy is moving over the groove. This cover is formed of a flat metal plate, H, having curved sides and a rounded or tapering point. It is held by a pivot, *h*, upon the end of the angular plate G, upon which it turns, and it is kept in line over the opening by means of the rubber springs I, secured to and beneath the broad end in the rod *i*, Fig. 3, so

that it will yield and turn to one side under pressure against the curved sides, and will move back into place when this force is removed.

The cover H is held down from any vertical movement upon the rails by means of the T-headed bolt J, which works through and beneath the slots in the rails, so that the cover may not be bent and raised up out of place.

As thus constructed and arranged, the passage of the gripe-bar along the switch-groove in the direction of arrow *x*, Fig. 2, will press against and move the cover H from over the groove until the dummy passes to the main track, when the plate will move back into position again; and the same action takes place when the dummy passes up the main track in the direction of the arrow *y*. The cover H is moved from place by the action of the gripe-bar every time the dummy passes it, and is returned into place again by the springs I. Thus it is automatic in its office of keeping the opening always protected.

The endless rope X is arranged below the rails B B' within the tunnel, at a distance below the top of the groove-rails somewhat greater than the distance between the rollers of the griping-bar and the top of the rails, except at the ends of the road, and at this part the rope is held at an angle with the level of the track, and the perpendicular distance between the rope and the rails is gradually decreased until at a point in front of the bumper-head *e*, where the distance coincides with the distance of the gripe-rollers from the top of the rails. Thus, after the dummy has passed from the switch to the main track, the rollers of the gripe will engage with and grasp the rope when they reach the point above mentioned, where the position of the rope coincides with a line running between the upper and lower rollers of the gripe; and until the dummy reaches this point the gripe-bar is kept away from contact with the rope, after passing the switch, by means of the curved form given to the angle-irons of the groove and to the rails of the track proper, as shown in Fig. 1 at O.

At this portion of the track and groove the rails are slightly curved for a proper distance, so that the dummy, in passing this point, deviates from a straight line or path, and keeps the gripe-bar away from the rope until the straight portion of the track is reached, when the path of the gripe-bar and the line of the rope are made to coincide, and the wheels of the gripe engage with the rope again.

The distance of the rollers of the gripe from the top of the road is always fixed and inviolable, so that after the dummy has left the rope on one track, and has passed to the other track, the rope must be held in position at some point beyond the switch, so that the griping-rollers may engage with it again.

This manner of running the dummy from one track to the other and taking up the rope again necessitates the employment of a device or means for depressing the rope at and below the switch, in order to allow the gripping bar and rollers to cross over the rope and pass to the side of it; and this device consists of the curved depressing-lever *K*, pivoted at *L* to the frame or permanent part of the tunnel, and provided with a sheave, *k*, at the end projecting over the rope. This lever is held up with its end above the rope by the small bracket *m* bolted to the side of one of the rails *B*, the rod *n* secured to the lever, and the rubber spring *M* placed between the bolt-head or nut on the end of the rod and the curved end of the bracket, so that when the end of the lever *K* is pressed down the compression of the spring *M* will take place, and when the lever is released the reaction of the spring will raise the end of the lever again.

The top edge of the lever *K* is placed at an angle with, and in the line of travel of, the gripping mechanism, or so that the pivoted end of the lever is lower than the end bearing the roller *k*, whereby the gripe, in passing along the switch-groove in the direction of the arrow *x*, comes in contact with the top of the lever, and, pressing it down, depresses the rope and affords a clear passage over it for the gripping bar and rollers. This lever *K* is also curved at the free end, in line with the path traversed by the gripe when it is engaged with the rope, so that when the dummy passes up the main track in the direction of the arrow *y*, Fig. 2, the lever will be turned to one side out of the path of the gripping-rollers, but will spring back again over the rope when the gripe-bar has passed by it. This curvature of the depressing-lever *K* is shown in Fig. 7 of the drawings.

These several parts, thus constructed, are placed and arranged at the terminus of the road, as well as at those places where it may be required to have a switch or siding from the main track.

The rope used as the propelling power is supported on wide-faced pulleys held in bearings provided for them on the brackets *A*. The bearings for one of those pulleys are shown at *N*, Figs. 1 and 8. They are kept constantly lubricated by means of the reservoirs *P*, situated at the top of the track, from which pipes *p* lead down to the oil-chambers *q* in the journal-boxes *R*. These reservoirs *P* are bolted to the side of the angle-rails *B*, and are made with a central oil-chamber, *r*, having its opening protected by a sliding cover, *Q*, and two channels, *s s*, leading from the sides of this cover down to and through the bottom of the reservoir. The pipe *p*, at the bottom of this oil-chamber, leads down to the chamber within the journal-box *R*, so that a supply of oil to the journals is constantly kept up as long as the reservoir is provided with oil.

The journal-box *R* is made in two parts, *R*

*R'*, and in the lower one a chamber is formed, communicating with the bearing-surface of the journal through the slots or openings *t t*.

The cover of the reservoir is made to slide upon the ledges cast on the inner sides, and has a rib projecting perpendicularly from one end, which engages with the side of the ledge, and prevents the cover being moved from over the mouth of the oil-chamber unless the end is first raised up by means of a curved wire or other suitable tool. Thus the reservoir cannot be uncovered and tampered with by any person unacquainted with its manipulation.

By this means the journals of all the underground pulleys and other working mechanism having frictional surfaces are lubricated from the surface of the road without taking up and disturbing any portion of the track or tunnel.

The side channels *s s* are provided for the purpose of permitting the dirt that may accumulate on the top of the cover and within the opening to be cleaned off and discharged at the bottom of the reservoir through the channels when it is desired to slide back the cover and fill the reservoir.

Having thus fully described my invention, what I claim, and desire to secure by Letters Patent, is—

1. The construction and arrangement together of the brackets *A A* and the rails *B B'*, forming the frame or skeleton for a rope-tunnel for endless rope traction-railways, said brackets forming a support for the groove-rails, and for the planking forming the sides or shell of the tunnel, substantially as herein described and specified.

2. In an endless-rope traction-railway, the combination of the tunnel or rope-chamber supported upon sills, so as to form a continuous sewer or channel beneath and communicating with the said rope tunnel or chamber, substantially as described and shown.

3. In an endless-rope traction-railway, the angle-irons *B B'*, to form a groove for the gripping mechanism of the dummy, by which a vertical bearing and guiding surface is formed within the groove for the vertical guiding-rollers of the gripe-bar, that acts to keep the bar from contact with the sides of the groove, arranged and applied substantially as and for the purpose set forth.

4. The curved depression-lever *K*, with its sheave *k*, for depressing the rope in endless-rope traction-railways at the points of switching, and at other points when it is necessary to carry the gripe-bar across the rope, said lever being constructed and arranged to operate substantially in the manner and for the purpose herein described and specified.

5. In combination with the groove-rails *B B'* and the bracket *A*, with its closed head *C*, the grooved bumper *e* and its bumper-rod *E*, with the rubber spring for receiving the shock of the gripping-bar of the dummy at the terminus of the groove in endless-rope traction-

railways, constructed and combined to operate together, substantially as and for the purpose herein described.

6. In an endless-rope traction-railway, the combination, with the rope tunnel or chamber, of pulleys journaled in the same, upon which the rope runs, and means for lubricating the bearings of such pulleys from the outside of the tunnel, substantially as described and shown.

In testimony that I claim the foregoing I have hereunto set my hand this 10th day of October, 1876.

ASA E. HOVEY.

Witnesses:

WILLIAM HARNEY,  
C. W. M. SMITH.