

F. STROBEL & C. M. IDLEMAN.
CIRCULAR-SAW MILLS.

No. 195,416.

Patented Sept. 18, 1877.

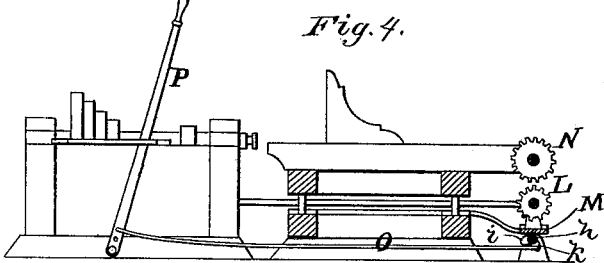
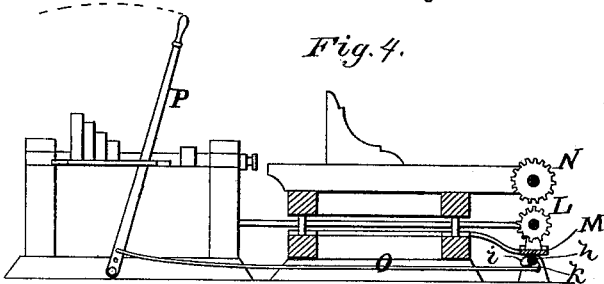
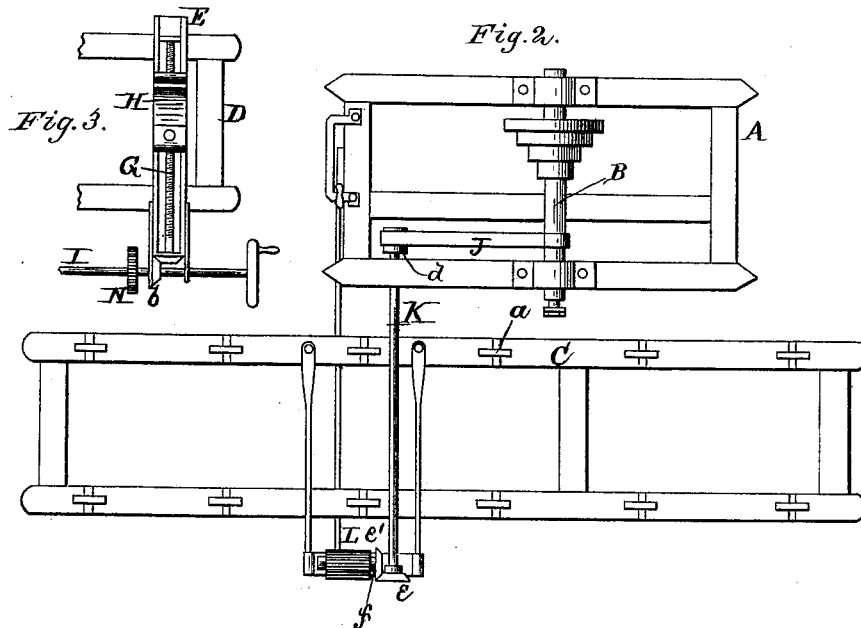
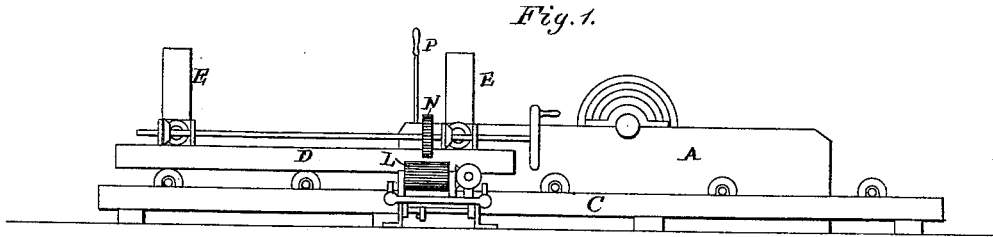

WITNESSES
Henry N. Miller
Frank Gall

INVENTOR
F. Strobel
and
C. M. Idleman
Alexander Mason
ATTORNEYS

UNITED STATES PATENT OFFICE.

FREDERICK STROBEL AND CICERO M. IDLEMAN, OF MARION, OHIO.

IMPROVEMENT IN CIRCULAR-SAW MILLS.

Specification forming part of Letters Patent No. **195,416**, dated September 18, 1877; application filed August 2, 1877.

To all whom it may concern:

Be it known that we, FREDERICK STROBEL and CICERO M. IDLEMAN, (STROBEL & IDLEMAN,) of Marion, in the county of Marion and in the State of Ohio, have invented certain new and useful Improvements in Circular-Saw Mills; and do hereby declare that the following is a full, clear, and exact description thereof, reference being had to the accompanying drawings, and to the letters of reference marked thereon, making a part of this specification.

Our invention relates to screw-block head-setters for saw-mills; and it consists in the devices for throwing the head-setting mechanism in and out of gear with the operating mechanism, whereby the motion of the saw-mandrel may be communicated to the head-setting device, as will be hereinafter more fully set forth.

In order to enable others skilled in the art to which our invention appertains to make and use the same, we will now proceed to describe its construction and operation, referring to the annexed drawings, in which—

Figure 1 is a side elevation of a saw-mill embodying our invention. Fig. 2 is a plan view of the same with the log-carriage removed. Fig. 3 shows a part of the log-carriage, and Fig. 4 is a transverse vertical section through the mill.

A represents the frame containing the saw-mandrel B.

C C are the ways with wheels *a a*, on which the log-carriage D moves.

E is the head-block with knee H, operated by a screw-shaft, G, connected by bevel-gears *b b* with a shaft, I, having a hand wheel or crank for setting the knees by hand in the usual manner.

J is a belt going over the saw-mandrel B, and over a pulley, *d*, on the end of a shaft, K, which runs through to the other side of the log-carriage, where it has a beveled cog-wheel,

e. This wheel meshes with a similar wheel, *e'*, on a shaft, *f*, which runs through an elongated cogged roller, L, and has its bearings in lugs on a plate, M.

Immediately above this cogged roller is a cog-wheel, N, secured to the shaft I of the log-carriage.

Under the plate M is a rod, *h*, with two eccentrics, *i i*, and a short crank, *k*, in the center, from which latter a rod, O, runs through to the main saw-frame A, and connects with a lever, P, as shown.

By means of this lever the rod *h* may be turned to raise the eccentrics *i*, and thereby also the plate M, so as to throw the cogged roller L in gear with the cog-wheel N, and thus move the log by the steam-power instead of by hand.

Having thus fully described our invention, what we claim as new, and desire to secure by Letters Patent, is—

1. The combination of the saw-mandrel B, belt J, shaft K, gears *e e'*, rod *f*, cogged roller L, and cog-wheel N on the shaft I, and a mechanism for intermittingly throwing the roller L in gear with the cog-wheel N, substantially as and for the purposes herein set forth.

2. The combination, with the plate M, carrying the cogged roller L, of the shaft *h*, with eccentrics *i i* and crank *k*, the rod O and lever P, with a mechanism for communicating motion from the saw-mandrel to the roller L, substantially as and for the purposes herein set forth.

In testimony that we claim the foregoing we have hereunto set our hands this 2d day of July, 1877.

FREDERICK STROBEL.
CICERO M. IDLEMAN.

Witnesses:

B. F. STAHL,
HANAH STROBEL.