

H. H. SCOVILLE, Jr.  
 STAMP-MILL MORTARS.

No. 195,457.

Patented Sept. 25, 1877.

Fig. 1.

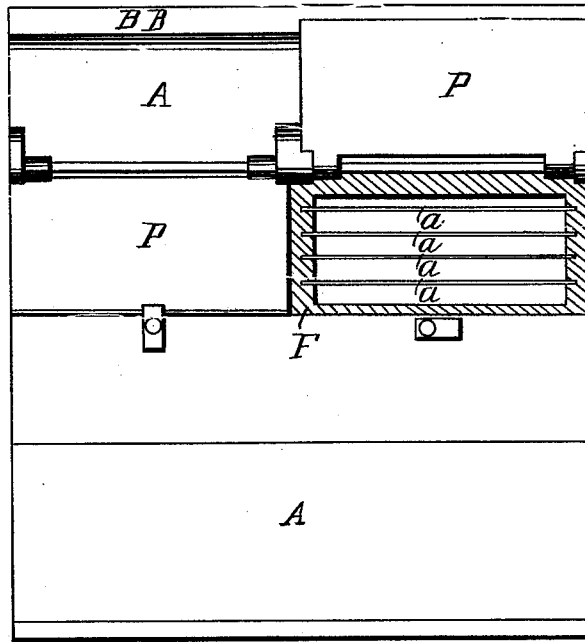
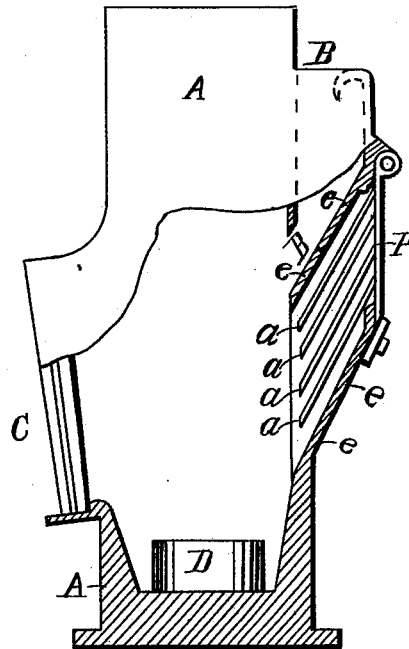

Fig. 2.



Witnesses  
 Chas. M. Brown  
 Frederick Hague.

Hiram H. Scoville, Jr. Inventor

Attorneys

# UNITED STATES PATENT OFFICE.

HIRAM H. SCOVILLE, JR., OF CHICAGO, ILLINOIS.

## IMPROVEMENT IN STAMP-MILL MORTARS.

Specification forming part of Letters Patent No. 195,457, dated September 25, 1877; application filed July 19, 1877.

*To all whom it may concern :*

Be it known that I, HIRAM H. SCOVILLE, Jr., of the city of Chicago, in the county of Cook and State of Illinois, have invented a new and useful Improvement in Stamp-Mill Mortars, used for crushing ores, which improvement is fully set forth in the following specifications and accompanying drawing, in which—

Figure 1 is a rear elevation of a five-stamp mortar containing my improvement, and Fig. 2 a transverse section of the same.

My invention relates to that class of mortars used for wet-crushing, in which it is desirable to save as much as possible of the metal contained in the ore to be crushed immediately within the mortar itself; and its object is to present a series of amalgamating-plates in such a position that both sides of each plate shall receive the splash directly from the falling stamps, and thereby expose a large amalgamating surface in a convenient space, where it will be the most effective in collecting the freed metal of the ore.

I am aware that amalgamating-plates disposed around the sides of the mortar are in common use; but, so far as I know, they have never been applied in a series, one above the other, so placed that both of their surfaces were made for available amalgamation.

A A is the mortar; B B, the opening and space through which the ore is fed for crushing; C, the opening in front, guarded by a screen, through which the surplus water and finely-pulverized particles of ore make their escape; and D, the die between which and the falling stamp the ore is crushed. At the back of the mortar, inclosed above and below by the walls *eeee*, is an open space having its inner opening presented to the surface of the die D. Within this space are placed the amalgamating-plates *a a a*, which slide in freely from the back side, on suitable bearings at their ends, in the walls of the mortar. They (the plates) are prevented from falling or jarring farther forward than is desired by stops attached to the mortar at each lower corner, against which each plate rests. P is a plate hinged on the outside of the mortar, which is closed tightly over the space containing the plates *a a a* when the mill is in operation.

By means of the opening in the rear of the mortar covered by the plate P, and the manner of placing the plates *a a a* on their bearings in the mortar, hereinbefore described, these plates may be readily removed for inspection or removing the accumulated amalgam.

I find it convenient in a five-stamp mortar to divide the space containing the plates *a a a* by a partition, F, in the middle, with bearings and stops like those at the ends, in order that the plates may be stiffer and better able to support the work they have to perform.

I do not confine myself to four of these plates, as here shown, for it is evident that a greater or less number may be thus applied.

It is also evident that amalgamating-plates may be placed in a similar manner at the ends of the mortar.

The plates perform their offices in the following manner: Ore being fed into the mortar at B B, and supplied with a sufficiency of water, the machinery of the mill is set in operation, and each stamp as it falls on its die splashes the water and pulverized ore over the plates *a a a*, bringing the material in contact with the under as well as the upper surfaces of the plates, and, the plates being inclined at an acute angle with a perpendicular line, the material immediately falls back to the bottom of the mortar, to be again and again splashed into contact with the plates. The ore is thus frequently and forcibly brought in contact with a large amalgamating surface in a very favorable manner for saving its metallic particles.

Having thus described my invention, what I claim as new, and desire to secure by Letters Patent, is—

In combination with a mortar for wet-crushing ores, a series of parallel plates, *a a a*, amalgamated on both sides and placed in the line of the splash, and a closing door, P, behind them, so that said plates, or either of them, may be removed, substantially as described.

HIRAM H. SCOVILLE, JR.

Witnesses :

CHAS. M. BROWN,  
FREDERICK HAGUE.