

E. B. VIETS.
 APPARATUS FOR SHAPING PANTALOONS.

No. 195,467.

Patented Sept. 25, 1877.

Fig. 1.

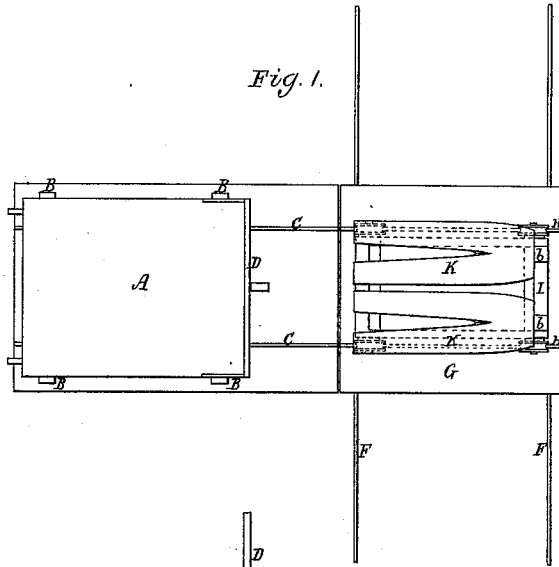

Fig. 2.

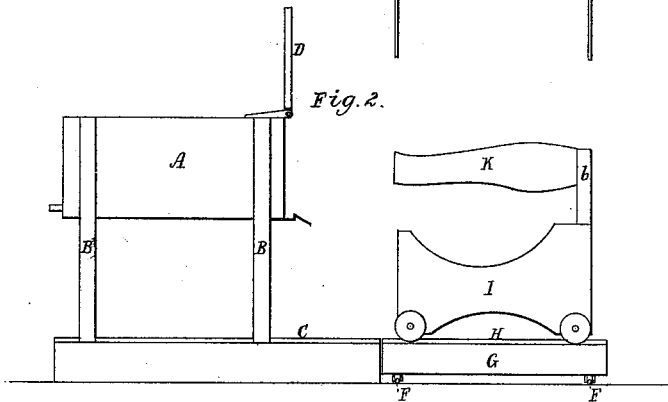
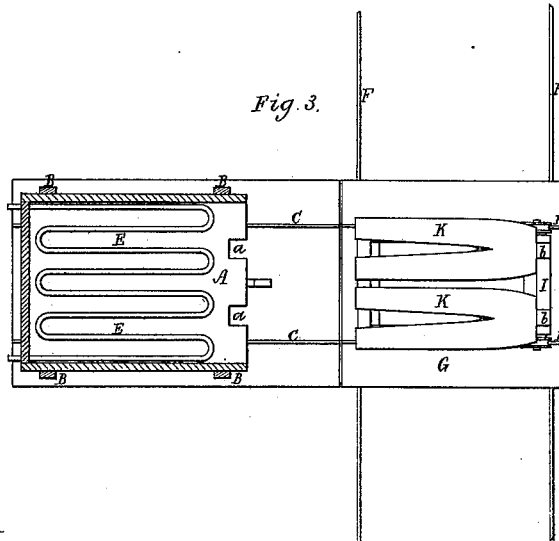

Fig. 3.



Witnesses.
S. W. Pipet.
L. W. Colwell.

Inventor
Ellen B. Viets
 by her attorney
R. W. Solly.

UNITED STATES PATENT OFFICE.

ELLEN B. VIETS, OF BOSTON, MASSACHUSETTS.

IMPROVEMENT IN APPARATUS FOR SHAPING PANTALOONS.

Specification forming part of Letters Patent No. 195,467, dated September 25, 1877; application filed February 22, 1877.

To all whom it may concern:

Be it known that I, ELLEN B. VIETS, of Boston, of the county of Suffolk and State of Massachusetts, have made a new and useful apparatus for Shaping Trousers; and do hereby declare the same to be fully described in the following specification, and represented in the accompanying drawings, of which—

Figure 1 is a top view, Fig. 2 a side elevation, and Fig. 3 a horizontal section, of an apparatus embodying my invention.

My invention consists of the combination of a drying or steaming box and its supporting-platform, a truck, and a carriage, provided with one or more trousers-shapers, all being constructed, arranged, and to operate substantially as hereinafter set forth.

I would remark that the oven or drying-box may be used for steaming trousers on a shaper, should such be desirable, in which case steam would have to be let directly into the box, the coil in said box being subsequently used, if necessary, for effecting the drying of the garment on the shaper.

In such drawings, A denotes a drying-box or chamber, supported on posts or standards B, over a short platform or railway, C C. The said drying-box A is open at its inner end, and there provided with a door, D, to close the opening. It is also notched in its bottom, as shown at *a a*, and has on said bottom a heating-coil, E, through which steam or hot air is to be forced while the apparatus may be in use.

The platform or railway C C is elevated above, and arranged at right angles with, another platform-floor or railway, F F, upon which there is placed a wheeled truck, G, to run thereon.

On the top of the truck G there is or may be a railway, H H, to receive a carriage, I, provided with one or more posts or standards, *b*, each post having projected from it a trousers last or shaper, K, all being as represented.

By moving the carriage from the truck G, underneath the drying-box, until the standards *b* may enter the notches *a a*, the last or lasts K will be introduced into the said box. This having been done, the cover of the box may be closed down, so as to inclose the last or lasts within the box. If we suppose a pair of trousers, in a wet or damp state, to have

been stretched on each last or former K prior to its introduction into the box, they may be dried on the former when in the box, and submitted to the heat therein.

After the trousers may have been dried, the carriage should be moved back upon the truck G, and the latter be moved laterally on its platform or railway F F, in order to allow another truck, with another shaper or shapers, to be moved up to and under the oven or box, so as to introduce its shaper or shapers into such box.

By my apparatus, provided with an additional truck, trousers may be drying in the box while others are in the act of being prepared for being dried.

I claim—

1. In combination with the drying-box A and its supporting-platform or railway C C, the truck G and the carriage I, provided with one or more trousers-shapers, K, all substantially as described.

2. The combination, with the box A, provided with one or more recesses, *a a*, of the shaper or shapers K, supported by one or more posts, *b*, substantially as described, and for the purpose set forth.

3. The combination of the carriage I and one or more trousers or garment shapers, K, applied thereto, all being for use substantially as explained.

4. The combination of a carriage, I, one or more trousers or garment shapers, K, and a drying or steaming chamber or box, A, provided with means of introducing into it steam, or of heating air in it, all being essentially as set forth.

5. The combination of one or more garment-shapers, K, a supporting-carriage, I, therefor, and guides or rails C C, with a drying or steaming chamber or box, A, all being substantially as specified.

6. The combination of the guides or rails F F, H H, and C C, the truck G, the carriage I, one or more trousers or garment shapers, and a steaming or drying chamber or box, A, all being for use, and for the purpose or purposes substantially as set forth.

ELLEN B. VIETS.

Witnesses:

R. H. EDDY,
J. R. SNOW.