

L. J. BAZZONI.
SPRING-SEATS FOR WAGONS.

No. 195,561.

Patented Sept. 25, 1877.

Fig. 1.

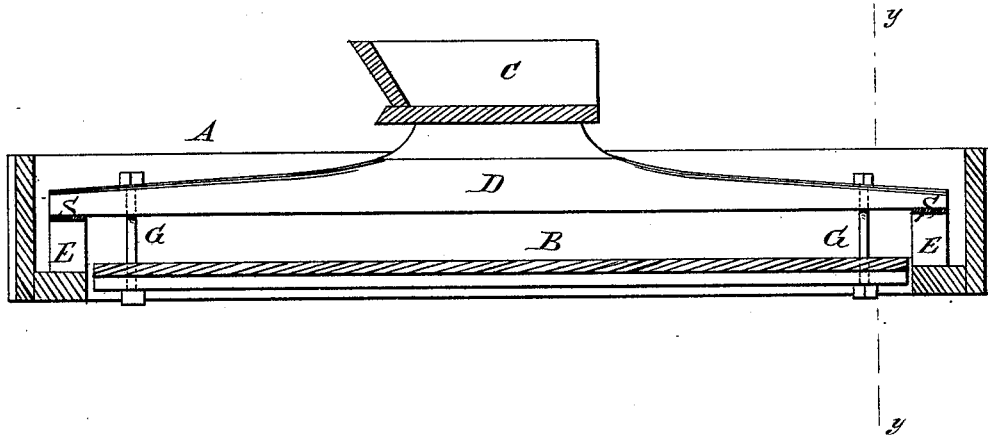
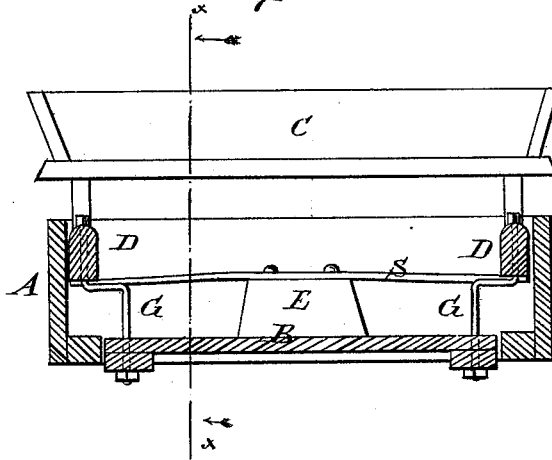

Fig. 2.



WITNESSES:

C. M. Nida
J. H. Scarborough

INVENTOR:

L. J. Bazzoni
BY *M. M. M. Co.*

ATTORNEYS.

UNITED STATES PATENT OFFICE.

LEWIS J. BAZZONI, OF NEWBURG, NEW YORK.

IMPROVEMENT IN SPRING-SEATS FOR WAGONS.

Specification forming part of Letters Patent No. 195,561, dated September 25, 1877; application filed August 24, 1877.

To all whom it may concern:

Be it known that I, LEWIS J. BAZZONI, of Newburg, county of Orange and State of New York, have invented a new and Improved Wagon-Spring, of which the following is a specification:

This invention has relation to a mode of mounting wagon-seats; and the nature of my invention consists in suspending the bottom of the wagon-body from the reach-bars of the seat, when these bars are supported at their ends upon springs, as will be hereinafter explained.

In the annexed drawings, Figure 1 is a section taken longitudinally and vertically through the wagon-body and seat attachment in the plane indicated by dotted line *x*, Fig. 2. Fig. 2 is a section taken transversely through the wagon in the course indicated by dotted line *y y*, Fig. 1.

Similar letters of reference indicate corresponding parts.

The letter A indicates the body of the wagon, which is properly braced and strengthened; and B designates the bottom of the wagon-body. The seat C is secured to two longitudinal reach-bars, D D, which are supported at

their ends upon springs S S, transversely arranged, and bolted at the middle of their length to blocks E, which blocks are secured to bottom pieces fixed to the body of the wagon. The bottom or platform B of the wagon-body is suspended from the ends of the reach-bars D D by means of angular hangers G, which are located at or near the four corners of the wagon-body.

It will be observed from the above description that the seat and the bottom of the wagon-body are elastically connected, so that they both move together. I thus save the driver from the inconvenience of shocks and concussions, and afford him an easy seat.

Having thus fully described my invention, I claim as new and desire to secure by Letters Patent—

In combination with the seat-reaches D and spring-supports therefor, the movable bottom B, suspended by hangers G from said reaches, substantially as described.

LEWIS JAMES BAZZONI.

Witnesses:

GEORGE ARMSTRONG,
PHILIP HOUSER.