

B. H. LOCKWOOD.
MACHINES FOR MAKING SPIRAL-SPRINGS.

No. 195,619.

Patented Sept. 25. 1877.

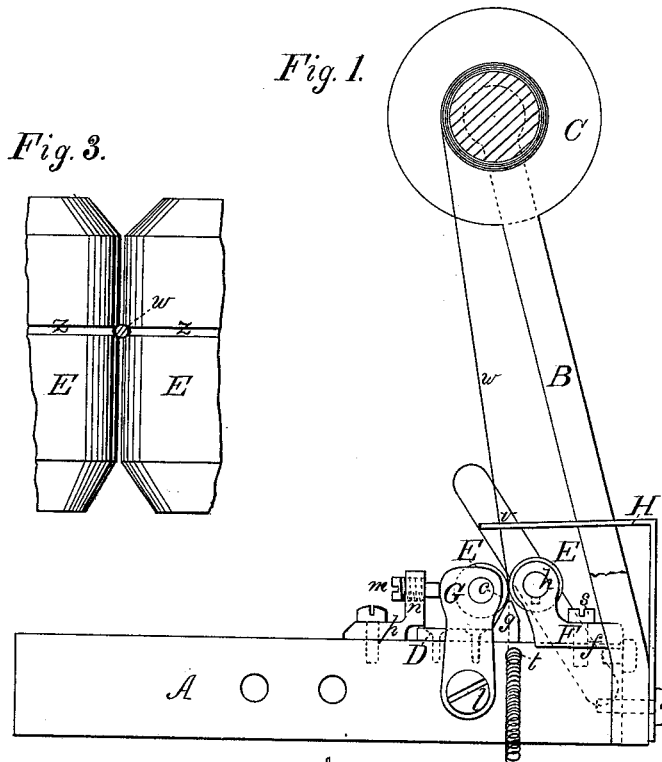

Fig. 1.

Fig. 3.

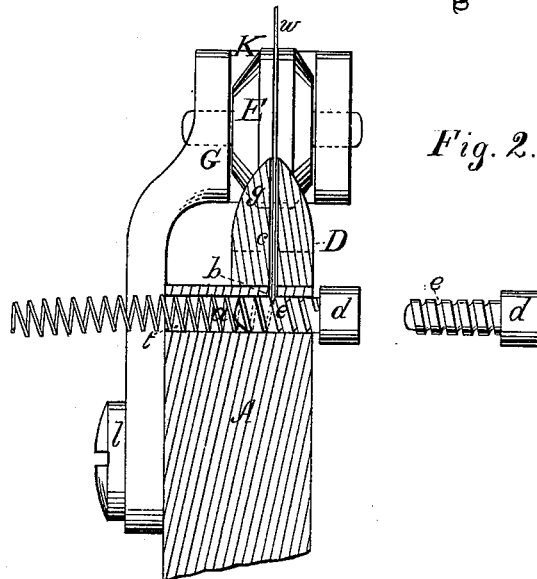
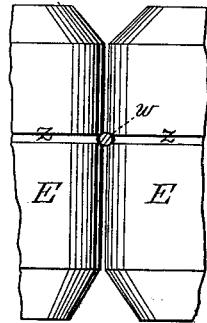

Fig. 2.

WITNESSES
Villette Anderson.
Walter C. Masi

INVENTOR
Byron H. Lockwood,
by E. W. Anderson,
ATTORNEY

UNITED STATES PATENT OFFICE.

BYRON H. LOCKWOOD, OF STAMFORD, CONNECTICUT.

IMPROVEMENT IN MACHINES FOR MAKING SPIRAL SPRINGS.

Specification forming part of Letters Patent No. **195,619**, dated September 25, 1877; application filed January 13, 1877.

To all whom it may concern:

Be it known that I, BYRON H. LOCKWOOD, of Stamford, in the county of Fairfield and State of Connecticut, have invented a new and valuable Improvement in Machines for Making Spiral Springs; and I do hereby declare that the following is a full, clear, and exact description of the construction and operation of the same, reference being had to the annexed drawings, making a part of this specification, and to the letters and figures of reference marked thereon.

Figure 1 of the drawings is a representation of a side view of the spiral-spring coiler with section of the reel. Fig. 2 is a transverse vertical section through the forming-chamber. Fig. 3 is a detail view, showing the approximate surfaces of the grooved friction-rolls.

This invention has relation to machines for making spiral springs; and it consists of certain details of construction hereinafter fully described, and pointed out in the claims.

In the accompanying drawings, the letter A designates the base bar or body of the machine. This, as usually constructed, has parallel sides and a plain upper surface; but its form may be varied according to requirement. If the bar form is employed, as illustrated, it is designed to be attached to a stand or other firm support.

B represents arms which extend upward above the bar and form supports for a spool or reel, C, upon which is coiled the wire to be fed to the machine. This reel is designed to be located directly over the feed-rolls of the machine, in order that it may not be bent in the feeding, the object being to deliver it to the feed-rolls with its cylindrical surface uninjured, and therefore possessing a certain degree of stability in relation to its axis.

a indicates the forming-chamber, cylindrical in form, and extending through the bar A transversely. An opening, *b*, through the top of the bar communicates with this chamber at right angles, said opening registering with the lower end of a guiding-perforation, *c*, in a conductor-plate, D. From one end of the forming-chamber a spirally-grooved forming-pin, *d*, is inserted therein, and so arranged that its groove *e* shall communicate with the aperture *b* of said chamber. At its other end

the chamber is open, and forms a delivery-tube, *t*. The plate D is secured to the bar A by means of screws or other suitable fastenings, and that portion which contains the guiding-perforation *c* is extended upward in the form of an angular spur or projection, *g*, for a purpose hereinafter mentioned.

E designates the feed-rolls. These are cylindrical in form, and provided with annular feeding-grooves *z*, which engage the wire *w* from the reel at the approximate portions of the rolls, and, when turned, force said wire into the perforated guide-spur *g*, which extends upward between said rolls as nearly as possible to their points of contact with said wire, in order that the length of free wire between said points of contact and the end of the spur may be reduced to a minimum, and that the maximum axial rigidity of the wire may be secured between these parts where no guide can be provided. The perforation *c* is therefore in a line tangential to the feed-rolls at the approximate points.

The driving feed-roll is mounted between bearings *h* in a plate, F, which is secured to the surface of the bar A by a screw, *s*, or other fastening, and is usually provided with longitudinal flanges *f*, extending downward over the sides of said bar to keep the plate firmly in position under the strain of the driving-power which is applied to an extension of the shaft of the roll.

The fellow roll is mounted in bearings in the fork K of an arm, G, which is secured to the side of the bar A by means of a pivot-screw, *l*. A set-screw, *m*, applied through the vertical branch *n* of a plate, *p*, serves to regulate the pressure between the rolls. When the set-screw is reversely moved the arm G may be swung backward, separating the rolls.

Above the feed-rolls a guide-arm, H, extends, the perforation *v* of which is over the perforation *c* of the guide-plate or conductor D and the approximate portions of the grooves of the rolls.

The wire is designed to pass through the perforation *v* of the guide-arm, and is kept thereby in the direct line referred to, when its direction above said arm is rendered somewhat oblique in unwinding from end to end of the reel.

The operation is as follows: The wire is drawn from the reel by the feed-rolls, and forced by the same into the perforated guide, by which it is directed into the forming-chamber and into the groove of the former *d*, by which it is carried around the chamber in a spiral line, and discharged through the tubular delivery end of the chamber in a spiral form.

What I claim as new, and desire to secure by Letters Patent, is—

1. The bar A, having chamber *a* and the entrance opening *b* in its upper edge, in combination with the spirally-grooved former, substantially as specified.

2. In a machine for making spiral springs, the conductor-plate, perforated in a line tangent to the friction-rolls at their points of contact with the wire, and extending from the forming-chamber nearly to said points, in combination with bar A, having perforation *b* and forming-plug *d e*, substantially as specified.

In testimony that I claim the above patent I have hereunto subscribed my name in the presence of two witnesses.

BYRON HUBBARD LOCKWOOD. [L. S.]

Witnesses:

CHARLES H. WEBB,
CHARLES E. HOLLY.