

W. J. DREW.
VEHICLE WHEELS.

No. 195,875.

Patented Oct. 2, 1877

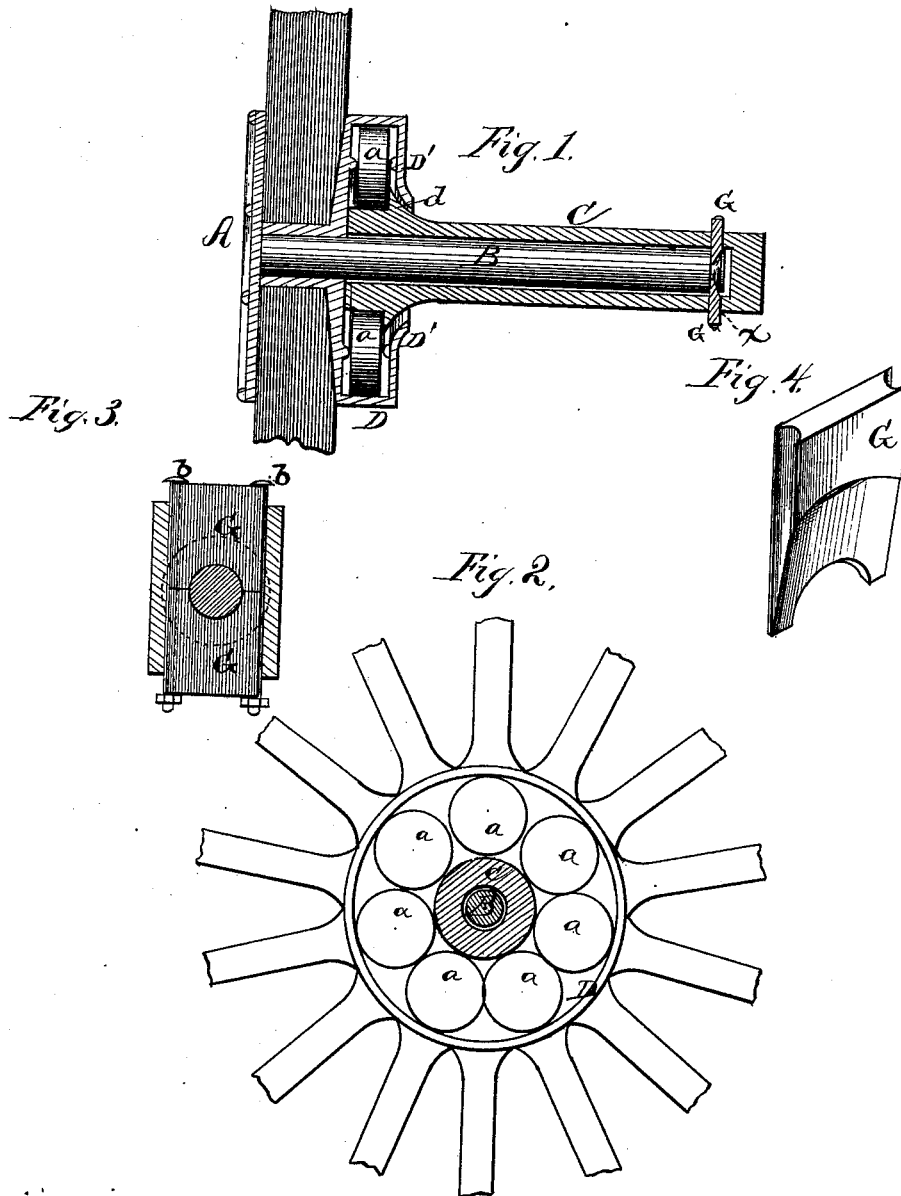

Witnesses:
A. O. Arthur,
C. L. Ernst,

Inventor
Walter J. Drew.

per

N. Alexander Bell
Attorneys,

UNITED STATES PATENT OFFICE.

WALTER J. DREW, OF GRAND RAPIDS, MICHIGAN, ASSIGNOR OF ONE-HALF HIS RIGHT TO WM. M. ROBINSON, OF SAME PLACE.

IMPROVEMENT IN VEHICLE-WHEELS.

Specification forming part of Letters Patent No. **195,875**, dated October 2, 1877; application filed September 5, 1877.

To all whom it may concern:

Be it known that I, WALTER J. DREW, of Grand Rapids, Kent county, Michigan, have invented certain new and useful Improvements in Vehicle-Wheels; and I do hereby declare the following to be a full, clear, and exact description of the same.

My invention relates particularly to wheels and axles for vehicles, though it is equally applicable for street and railroad cars; and it consists in providing the hub with a hollow rim having a sand band or projection on its inner side, and a stationary chair or box provided with a griddle or projection where it enters the hub, to hold friction-wheels to their place, and keys at the other end of the chair to hold the axle, all as hereinafter more fully set forth.

In the annexed drawing, to which reference is made, and which fully illustrates my invention, Figure 1 is a longitudinal section of my invention. Fig. 2 is a side view of the wheel. Figs. 3 and 4 are enlarged detailed views of the keys.

A represents the hub of a wagon-wheel, provided with an independent axle, B, secured therein. This axle projects through the center of a metal chair or box, C, the bore of which is larger than the axle, so as not to allow it to touch, but to bring the weight of the load upon the friction-wheels *aa*. These wheels are placed within the rim D of the hollow metal hub A, and travel around on the inside of the hub as the wheel revolves, and consequently reduce the friction, as it makes a rolling bearing. One side of the wheels *a* travels around on the box or chair C, which projects into the rim of the

hub, and is just large enough to fill up the vacant place after the rollers have been placed therein, and the other side travels around on the inside of the rim D of the hub, as above stated.

The axle B has a bearing at the inner end, or, in other words, it is made to fit the inner end of the box, where it is held in place by means of two keys, G G, entering a groove or neck, *x*, in the axle, and held in place by bolts *b*. The rim D is on its side provided or formed with a sand-band, D', to hold the wheels in the rim, and the chair or box C is formed with a collar or griddle, *d*, which enters into said sand-band, and excludes all dust and dirt.

The box or chair is fastened to the body of an ordinary wagon by bolts and gripes in such a manner as to make it perfectly rigid. At the rear end of the wagon it is placed and fastened between the bolster and axle-tree, and at the front end between the wooden axle-tree and sand-board.

For street-cars or railroad-cars the axle projects from one wheel to the other on the opposite side.

Having thus fully described my invention, what I claim as new, and desire to secure by Letters Patent, is—

A wheel-hub, A, provided with a hollow rim, D, having a sand-band, D', in combination with the axle B, friction-wheels *a*, stationary chair or box C, and keys G, all constructed substantially as and for the purposes herein set forth.

WALTER J. DREW.

Witnesses:

C. G. GODFROY,
W. O. GORMAN.