

H. C. BULL.
Locomotive Street-Car.

No. 195,881.

Patented Oct. 9, 1877.

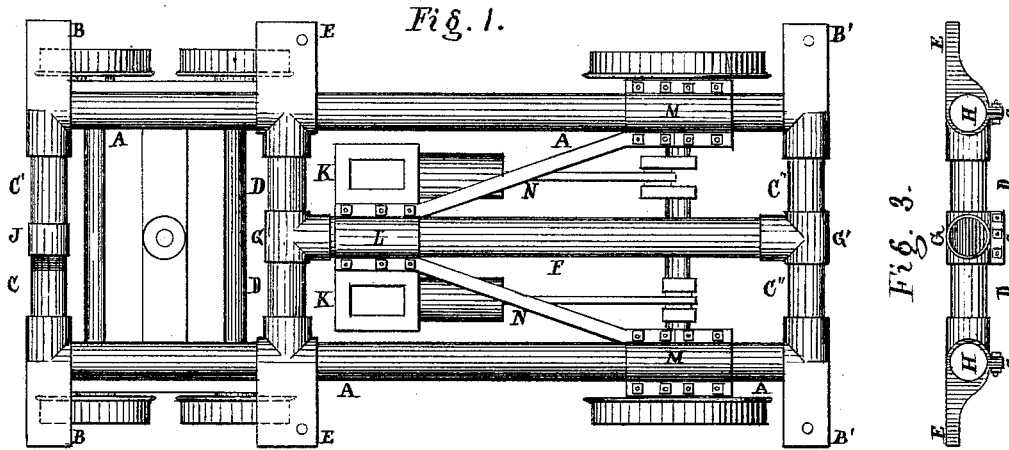
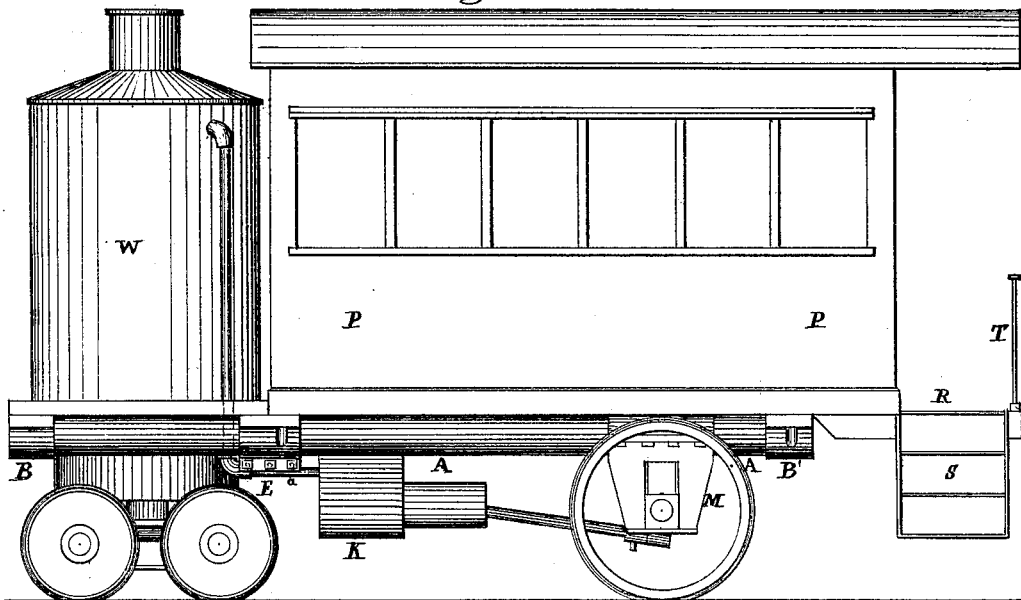

Fig. 2.



Witnesses.

H. Fuller Jr.
Octave Whittaker

Inventor.

Henry C. Bull.

UNITED STATES PATENT OFFICE.

HENRY C. BULL, OF BROOKLYN, NEW YORK, ASSIGNOR OF ONE-HALF HIS
RIGHT TO WILLIAM L. HEADLEY, OF SAME PLACE.

IMPROVEMENT IN LOCOMOTIVE STREET-CARS.

Specification forming part of Letters Patent No. **195,881**, dated October 9, 1877; application filed
July 7, 1876.

To all whom it may concern:

Be it known that I, HENRY C. BULL, of the city of Brooklyn, county of Kings, and State of New York, have invented a new and useful Improvement in the Construction of Street Locomotive-Cars; and I do hereby declare that the following is a full and exact description thereof, reference being had to the accompanying drawings, and to the figures and letters marked thereon, and in which—

Figure 1 is the plan or top view of the truck-frame; Fig. 2, a side elevation of the truck-frame and car-body; Fig. 3, a side view of the middle transom or cross-framing.

The same letters of reference are used to indicate the same parts in all the figures.

My invention relates to the construction and arrangement of street locomotive-cars, in which the propelling machinery and the passenger-compartment or car-body are carried upon the same truck-frame.

The side parts A A of the truck-frame, Figs. 1 and 2, are of wrought-iron tubing, about six and a half inches, more or less, in diameter, and are each formed in one piece, and have screws cut on their ends to enter and take into corresponding screws tapped in the brackets B B', and, in like manner, the cross-framing C C', C'' C'', and D D are screwed into the inner ends or sockets of the brackets B B, B' B', and E E, and the center piece F into the couplings G G'. But the couplings G G' are attached to their respective cross-pieces C'' C'' and D D by gripe-joints—that is, they are made to embrace the cross-pieces, as shown at G, Fig. 3—and have an open slot in the under side, with flanges, through which bolts are passed, as shown at a, Figs. 2 and 3, for the purpose of drawing the coupling tightly to the parts which they embrace.

In putting this frame together, I first attach the middle piece F to the inner sockets of the gripe-couplings G G' by screwing them together, as explained above. I then pass the end piece C'' C'' through the opening in G', and screw on the brackets B' B', and, in like manner, combine with the center piece F the middle cross-pieces D D and brackets E E. Then the side parts A A A A are passed through the open-

ings in the brackets E E, as shown at H H, Fig. 3, and are screwed home into the brackets B' B'. I then screw into each of the brackets B B the pieces of tubing C C', each of which is a little less than half the length of the cross-pieces C C' or D D. I run on the screwed coupling J till its edge is level with the end of the piece C. This is done to enable the brackets B B to be screwed onto the side pieces A A A A, after which the sleeve-coupling J is worked over till it embraces and secures the second piece C', which completes the truck-frame.

The steam-generator will rest upon and be attached to the truck-frame by the brackets B B and part of the brackets E E, and will pass down some distance into the open space within the frame, which is shown in Fig. 1, and that end of the truck-frame or car will be supported on a four-wheeled swiveling truck. The steam-cylinders and their appurtenances, as indicated at K K, Figs. 1 and 2, are attached to the middle piece F of the truck-frame by means of the carrier L, which is attached to the middle piece F by a gripe-coupling, as shown; and in the same way the pedestals M M, which carry the journal-boxes of the driving-axle, are secured to the side pieces A A A A. The carrier L is connected to the pedestals M M by the braces N N, thereby relieving the couplings of the carrier L and the pedestals M M from the alternate compressing and extension strains produced by the reciprocating movements of the engines; and all the machinery of the engines is so constructed and adapted to the truck-frame as to be below the level of the upper surfaces of the brackets.

The front end of the car-body P will rest on a part of the middle brackets E E, and will extend behind the rear brackets B' B', so as to throw the weight of the passengers or load upon the driving-wheels, which will be about under the middle of the load, thus increasing or diminishing the adhesion of the driving-wheels by the load or weight which has to be moved by them.

I make the car-body P P substantially the same as those which are in use on the horse-railroads, and secure it to the side brackets by steadying pins or bolts passing down

through them from the side sills of the car-body, so as to be easily removed or replaced when required.

I also attach to the car-body the rear platform R, steps S, and hand-railing T, together with a door to the car-body for entrance or exit by the rear platform R.

It is of great economical value to a company using a large number of these locomotive-cars to have the car-bodies portable or separable from the truck-frame; for, the truck-frame and its machinery being of an entirely different material and workmanship to the car-body, the repairs to these parts have to be made by entirely different sets of mechanics, and in different shops specially adapted for each branch of the work. Accordingly, when the truck-frame and car-body are separable, as described, each of said parts may be immediately taken to its own particular shop, that the repairs on both parts may progress simultaneously, instead of passing the whole car from shop to shop, till, one after the other, all the different repairs are finally completed. And, the truck-frames and car-bodies being interchangeable in this system, if either of the said parts gets injured, it may be immediately replaced by a like part, without interruption to the working of the road, so long as a car-body and a truck-frame, with its machinery in working condition, are on hand, thus avoiding the pecuniary loss which results from idle stock when the whole car and its machinery have to be laid up to have repairs put on one of the said parts only.

This system of the independent truck-frame and portable car-body has another very important advantage for the steam-generator.

The steam-engines and all the steam and water pipe connections being arranged upon the truck-frame and entirely unconnected with the car-body, the steam-pipe and water-pipe connections or joints are not disturbed or opened by the jarring or surging motions of the car-body, as is the case in all the street locomotive-cars at present in use, from the fact that the engine-work or its connections are attached to the car-body as well as to the framing upon which such car-body is built.

Having thus described my improvement in locomotive street-railroad cars, what I claim therein as new, and desire to secure by Letters Patent of the United States, is—

1. The truck-frame having the side brackets E E, in combination with the detachable car-body P P, substantially as described.

2. The combination of the side brackets, which carry the coach-body of the car, with the cross-framing of the truck, substantially as described.

3. The combination of the steam-cylinders with the central longitudinal portion of the truck-frame, in the manner and for the purpose substantially as herein described.

4. The combination of the central carrier of the steam-cylinders with the pedestals of the driving-axles, by means of the braces N N, in the manner and for the purpose substantially as herein described.

In testimony whereof I have hereunto subscribed my name to this specification in the presence of two subscribing witnesses.

HENRY C. BULL.

Witnesses:

F. A. FULLER, Jr.,

OCTAVE WHITTAKER.