

A. D. SCHAEFFER.
Paper-Box.

No. 195,904.

Patented Oct. 9, 1877.

Fig. 1.

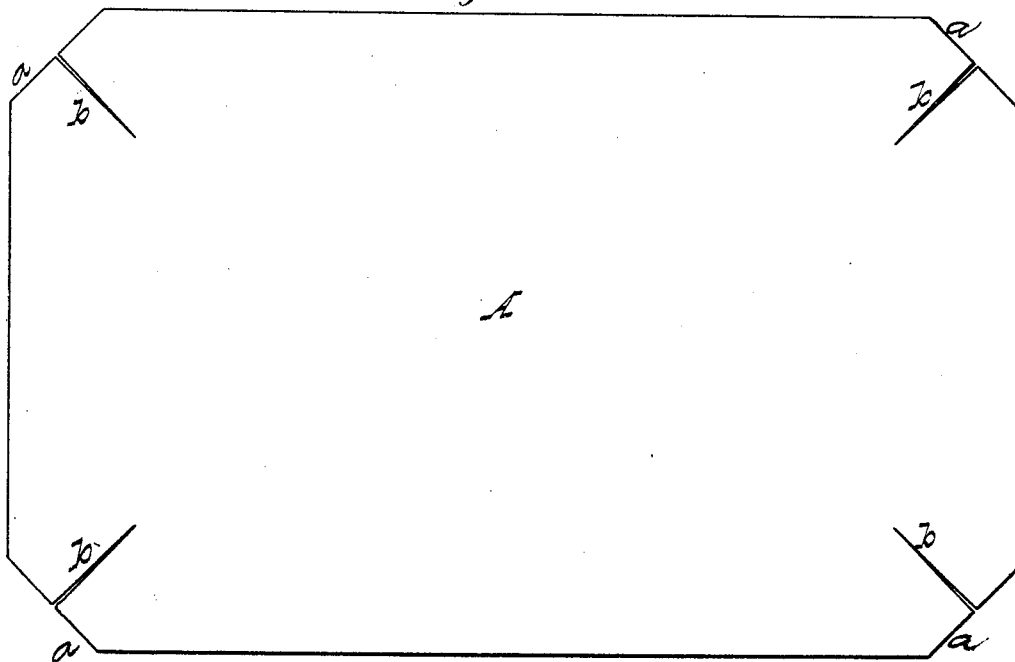
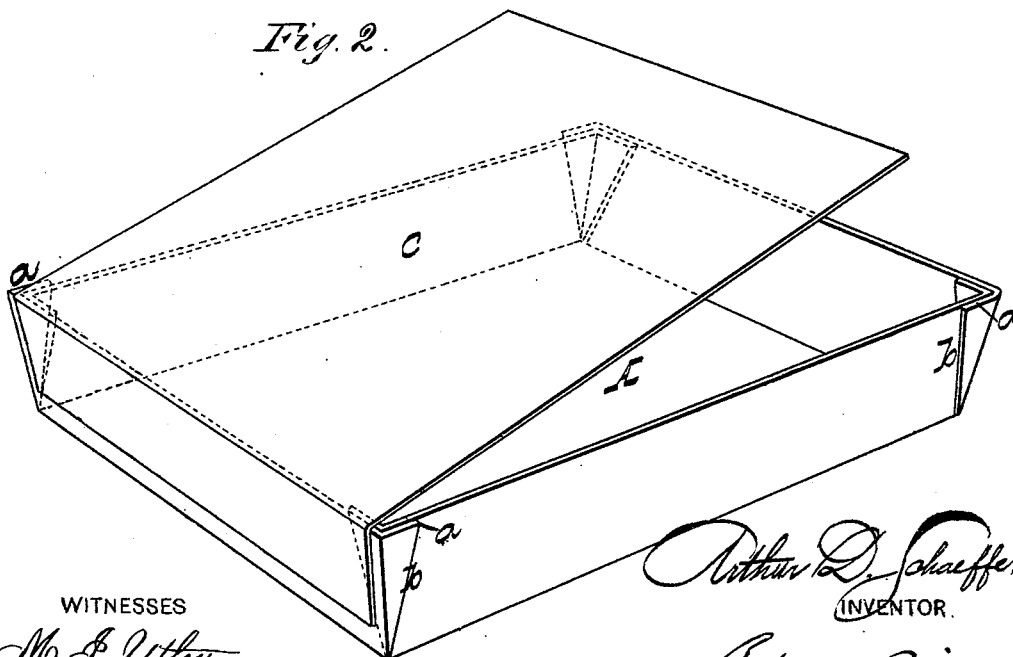

Fig. 2.



WITNESSES

Mo. S. Utley.
J. M. Kistner.

Arthur D. Schaeffer
INVENTOR.

Edson Brist

ATTORNEYS

UNITED STATES PATENT OFFICE.

ARTHUR D. SCHAEFFER, OF DAYTON, OHIO, ASSIGNOR TO HIMSELF, ROBT. A. ROGERS, D. E. MEAD, AND H. E. MEAD, OF SAME PLACE.

IMPROVEMENT IN PAPER BOXES.

Specification forming part of Letters Patent No. 195,904, dated October 9, 1877; application filed November 28, 1876.

To all whom it may concern:

Be it known that I, A. D. SCHAEFFER, of Dayton, in the county of Montgomery and State of Ohio, have invented certain new and useful Improvements in Paper Boxes or Dishes; and I do hereby declare that the following is a full, clear, and exact description thereof, which will enable others skilled in the art to which it appertains to make and use the same, reference being had to the accompanying drawings, and to the letters of reference marked thereon, which form a part of this specification, and in which—

Figure 1 is a plan view of a piece of pasteboard or other material cut and slitted to form my box or dish; and Fig. 2 is a perspective view of the box formed out of the said piece of pasteboard or other material, and having a cover or lid.

Corresponding parts in the two figures are designated by like letters.

This invention relates to a certain improvement in boxes or dishes, preferably made from pasteboard or stout paper, for use, particularly, in stores, in which to put lard, butter, &c., in retailing it; and it consists in cutting the paper or pasteboard, which is of a rectangular shape, at its corners obliquely to its right-angular portions, and thence slitting the truncated portions thus formed to the depth it is desired to impart to the sides and ends of the box, substantially as hereinafter more fully set forth.

In the annexed drawing, A refers to a sheet or piece of pasteboard, or stout paper, of a rectangular shape, the corners of which are cut obliquely or diagonally to the right-angular portions or sides and ends of the paper or pasteboard, as seen at *a a a a*. The object of

thus cutting the corners of the pasteboard or paper is to cause the upper ends of the overlapping and underlapping portions of the box to stand flush with each other, as seen in Fig. 2. The truncated portions of the paper *a a a* are slitted, as at *b b b b*, about midway of the diagonal or inclined surfaces thereof, to the depth it is desired to impart to the sides and ends of the box, and by which the said sides and ends are formed. Fold or crease the sides and ends of the paper to the depth permitted by the slits *b b b b*, and then overlap the ends, care being taken to have their upper edges stand flush with each other, after which paste the same together, and the box is made. A cover or lid, *c*, may be affixed to the box or dish, by paste or otherwise, to inclose or protect its contents.

As above intimated, this box or dish is particularly designed for use in stores, to put lard, butter, &c., in, in retailing it, and possesses cheapness—a great desideratum—and answers the purpose for which it is intended equally as well as a metallic vessel or dish.

Having thus described my invention, what I claim, and desire to secure by Letters Patent, is—

A box or dish constructed from flexible material, the corners of which are truncated, as at *a a*, and the said truncated portions *a a* slitted, as at *b b*, substantially as and for the purpose set forth.

In testimony that I claim the foregoing as my own I hereunto affix my signature in presence of two witnesses.

ARTHUR D. SCHAEFFER.

Witnesses:

ROBERT A. ROGERS,
P. D. W. SCHAEFFER.