

L. RIVERS.
Washing-Machines.

No. 195,953.

Patented Oct. 9, 1877.

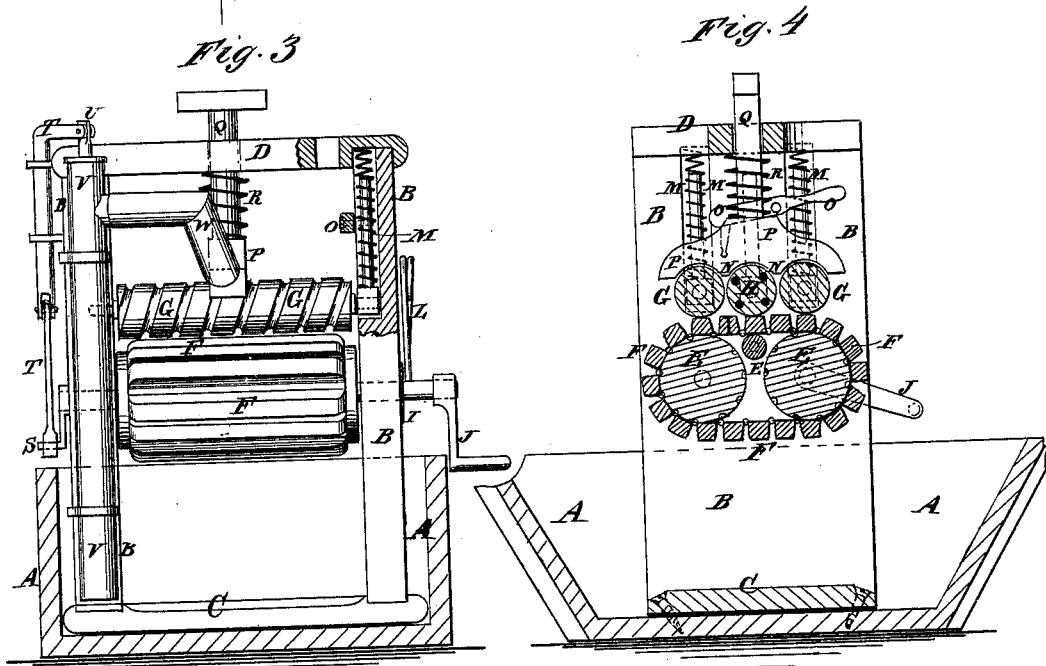
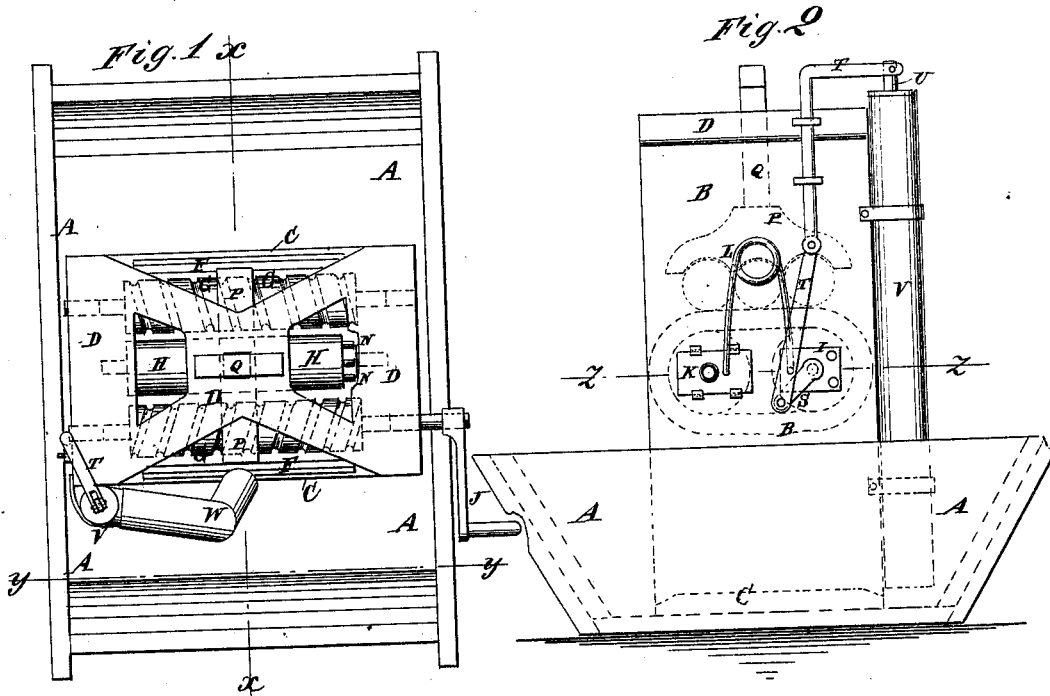

WITNESSES:
A. W. Amqvist
J. H. Scarborough

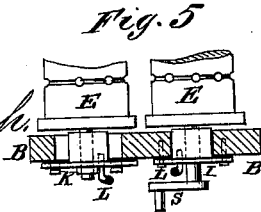

INVENTOR:
L. Rivers.
BY *[Signature]*
ATTORNEYS.

UNITED STATES PATENT OFFICE.

LOUIS RIVERS, OF AUBURN, OREGON.

IMPROVEMENT IN WASHING-MACHINES.

Specification forming part of Letters Patent No. **195,953**, dated October 9, 1877; application filed May 5, 1877.

To all whom it may concern:

Be it known that I, LOUIS RIVERS, of Auburn, in the county of Baker and State of Oregon, have invented a new and useful Improvement in Washing-Machines, of which the following is a specification:

Figure 1 is a top view of my improved machine. Fig. 2 is a side view of the same. Fig. 3 is a front view of the same, the suds-box being shown in section through the line *yy*, Fig. 1, and part being broken away to show the construction. Fig. 4 is a vertical section of the same, taken through the line *xx*, Fig. 1. Fig. 5 is a detail section taken through the line *zz*, Fig. 2.

Similar letters of reference indicate corresponding parts.

The object of this invention is to furnish an improved washing-machine which shall be so constructed as to keep the clothes supplied with fresh suds while being operated upon, which will allow the dirty water to run off freely when squeezed out, and which will enable the clothes to be put under any desired pressure while being operated upon.

The invention will first be described in connection with the drawing, and then pointed out in the claims.

A represents the suds-box. B are the standards, the lower ends of which are connected by a cross or base board, C, and their upper ends are connected by a cross or top board, D. The base-board C is secured to the bottom of the suds-box A, and the top board D has two large openings formed in it one upon each side of its center, to enable the progress of the work to be seen at any time.

To the standards B, a little above the top of the suds-box A, are pivoted three parallel horizontal rollers, E, around which passes an endless chain of slats or cross-bars, F. The bars F are rounded off upon their outer sides, and are hinged to each other at the side edges of their inner sides. The slats F are kept from longitudinal movement by collars or flanges formed upon the ends of the side rollers E, and by the grooves in said side rollers that receive the hinges of the said slats F.

The central roller E is made smaller than the side rollers E, and is placed in the space be-

tween the upper parts of said side rollers, in such a position that the upper sides of the three rollers E may be in the same horizontal plane, so as to hold the upper part of the endless chain of slats level while the clothes are being operated upon.

The journals of the forward roller E revolve in stationary bearings I attached to the standards B, and to the projecting end of one of said journals is attached the crank J, by which the machine is operated. The journals of the other side roller E revolve in bearings K placed in short cross-slots formed in the standards B.

L are strong V-springs, having a coil formed in them at their angle, and the ends of which are bent inward at right angles, and enter holes in the bearings I K, to keep the side rollers E pushed apart and the endless chain of slats F always under the proper tension.

G H G are three rollers placed directly above the three rollers E. The journals of the rollers G H G revolve in bearings placed in vertical grooves formed to receive them in the inner side of the standards B. The rollers G H G are held down upon the endless chain of slats F by spiral springs M placed above their bearings in the grooves of the standards B, and kept in place by guide-pins attached to said bearings.

The side rollers G are grooved spirally in opposite directions, to produce friction upon the clothes. The central roller H is smooth, and to one of its ends are attached ratchet pins or teeth N, to receive the engaging end of the lever-pawl O, pivoted to the standard B, so that the central roller H may be kept from revolving when more friction upon the clothes is wanted.

P is a block placed transversely above the middle part of the rollers G H G, and grooved upon its lower side to fit upon said rollers.

To the center of the block P is attached the lower end of the upright Q, which passes up through a hole in the center of the top board D, and has a cross-head or other handle attached to its upper end.

The block P is held down upon the rollers G H G by a spiral spring, R, placed upon the upright Q, and, when additional pressure is required, the operator grasps the upper end of

the upright Q, or the handle attached to said upper end, and bears down with any desired force.

To the journal of the forward roller E, opposite the crank J, is attached a short crank, S, to which is pivoted the lower end of the connecting-rod T, which is jointed in its middle part, and its upper part passes through keepers attached to the upper part of the standard B. The upper end of the jointed connecting-rod T is bent over at right angles, and to it is pivoted the upper end of the pump-rod U, so that the pump may be worked by the operation of the machine.

The pump-barrel V is secured to the forward edge of the standard B, and its lower end extends down nearly to the bottom of the suds-box A.

The discharge spout or nozzle W of the pump is bent to the rearward, and inclines downward, so as to discharge the water over the rollers G H G and upon the endless chain of slats F, so as to again saturate the clothes as soon as the water has been squeezed out of them by the action of the rollers and cross-slats. The dirty water, as it is squeezed out, passes between the slats F, and so down into the suds-box.

Having thus described my invention, I claim as new and desire to secure by Letters Patent—

1. The combination, with endless slat-belt F, of the spring-pressed rolls G H G, the outer roll spirally grooved and the inner roll smooth, to operate as and for the purpose described.

2. The combination of the stationary bearings I, the sliding bearings K, and the springs L with the journals of the side rollers E, the endless chain of slats F, and the standards B, substantially as herein shown and described.

3. The two side rollers G, grooved spirally in opposite directions, in combination with the central roller H, the endless chain of cross-slats F, and the standards B, substantially as herein shown and described.

4. The combination of the ratchet pins or teeth N and the lever-pawl O with the standard B and the central roller H, substantially as herein shown and described.

5. The combination of the roll H, slat-belt F, and the small roll E, as and for the purpose set forth.

LOUIS RIVERS.

Witnesses:

THOMAS SMITH,
WM. GRAHAM.