

W. C. CARLTON.

Axle-Gages.

No. 196,071.

Patented Oct. 16, 1877.

Fig 1

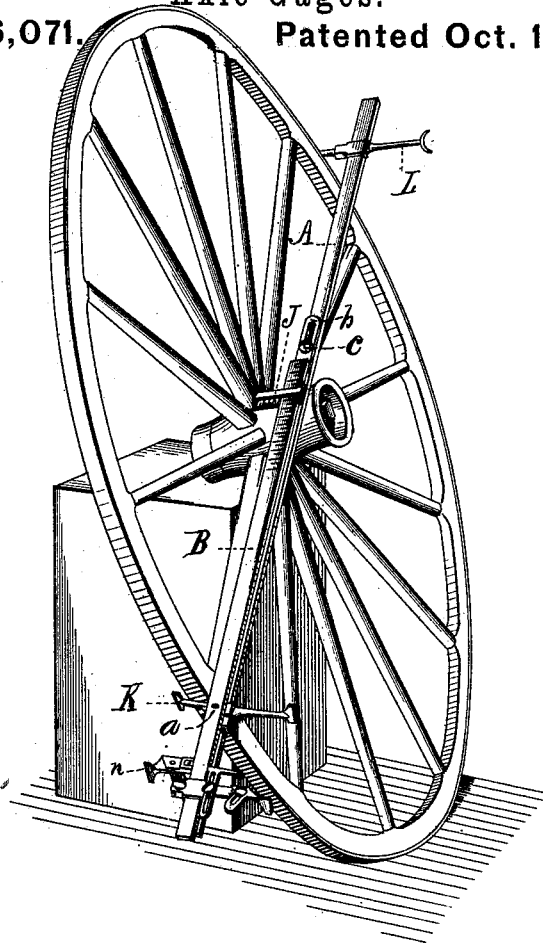
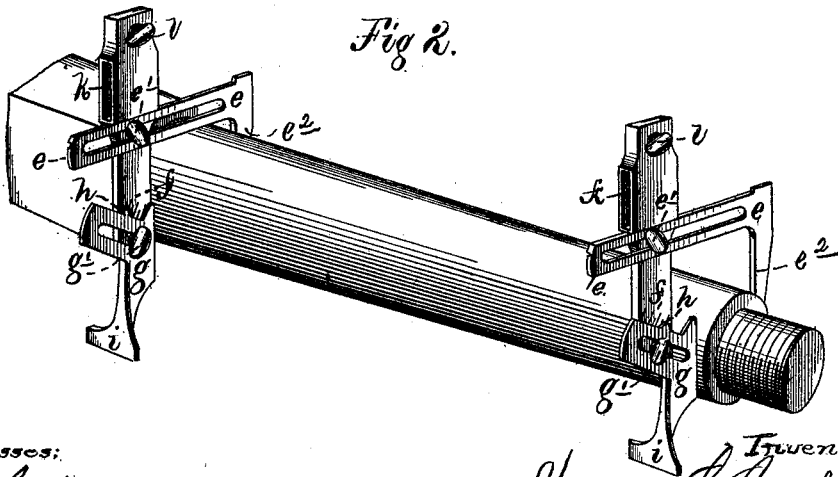

Fig 2.



Witnesses:
Geo. H. Graham.
E. J. Ward.

Inventor.
William C. Carlton
 By *A. L. Hamilton*
Atty.

W. C. CARLTON.
Axle-Gages.

No. 196,071.

Patented Oct. 16, 1877.

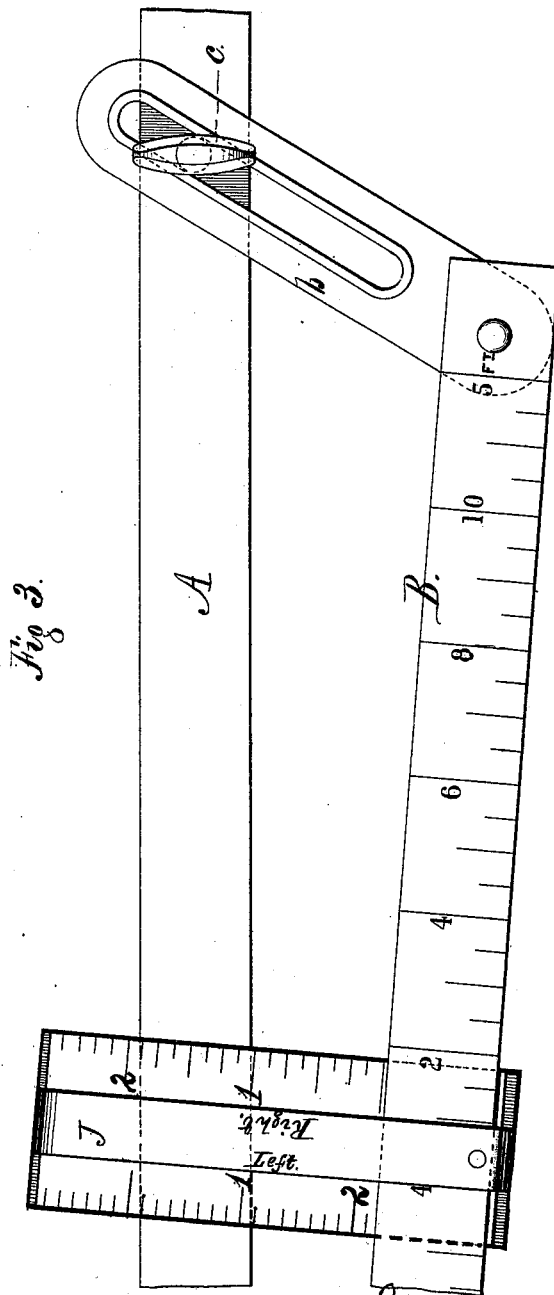

Fig. 3.

Witnesses:
E. G. Ward.
E. D. Curran

Inventor:
William C. Carlton.
 By *A. L. Thompson.*
Atty.

W. C. CARLTON.
Axle-Gages.

No. 196,071.

Patented Oct. 16, 1877.

Fig 5.

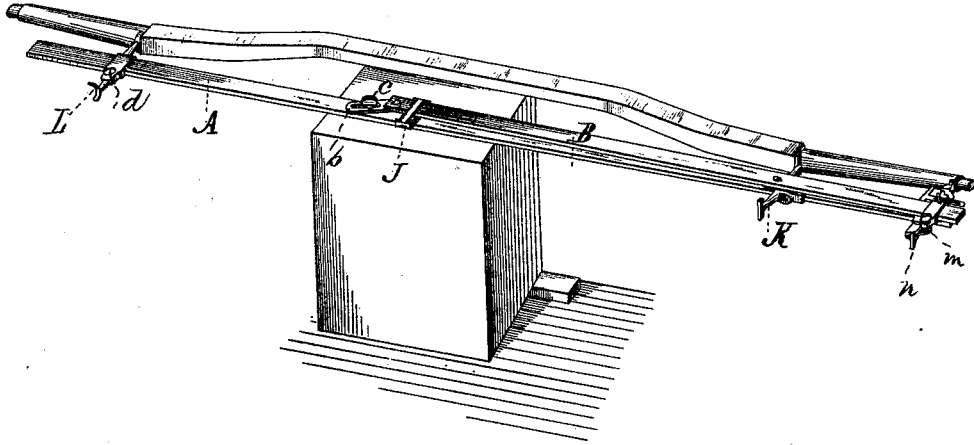
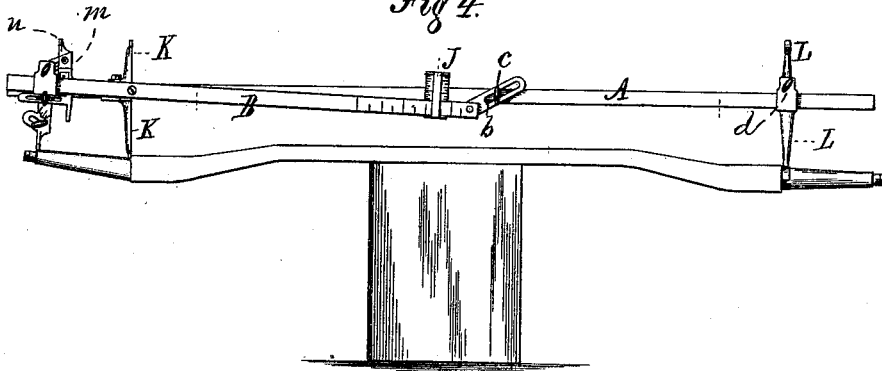

Fig 4.



Witnesses;

Geo. A. Graham.
E. J. Ward.

Inventor;

William C. Carlton
By *A. L. Thomson*
Atty.

UNITED STATES PATENT OFFICE.

WILLIAM C. CARLTON, OF BOISE CITY, IDAHO TERRITORY, ASSIGNOR TO
WILLIAM B. MORRIS, OF SAME PLACE.

IMPROVEMENT IN AXLE-GAGES.

Specification forming part of Letters Patent No. **196,071**, dated October 16, 1877; application filed
July 25, 1877.

To all whom it may concern:

Be it known that I, WILLIAM C. CARLTON, of Boise City, Ada county, Idaho Territory, have made certain new and useful Improvements in Axle Sets and Gages, of which the following is a specification:

This invention relates to that class of devices and apparatus that are designed for the setting and gaging of axles; and in the present instance the invention consists in a series of improvements on the axle set and gage, as shown and illustrated in Patent No. 179,264, issued to me on June 27, 1876, all of which improvements will be hereinafter fully set forth and described.

In the drawings, which form an essential part of this specification, Figure 1 is a view, in perspective, showing the application of the apparatus to a wheel for the purpose of taking half the height and dish thereof. Fig. 2 is a view, in perspective, showing the application of the taper-taking device to the spindle, for the purpose of taking the taper thereof. Fig. 3 is an enlarged view of a section of the apparatus, showing the double slide-rule in position for indicating the dish of the wheel. Fig. 4 is a view showing the apparatus as applied to the axle-spindles when setting, and Fig. 5 is a view showing the apparatus as applied in gathering the axle.

The same letters of reference found in the several figures of the drawings will locate and point out corresponding parts.

The want of a simple, reliable, and economical axle set and gage has long been recognized. Durability, comfort, and security in the use of every vehicle essentially depend on accurately-set spindles. It is also well known that but comparatively few sets of wheels are properly set. They are thus put out of line, changing the bearing of spokes and tenons, straining the whole running-gear, and producing hot boxes. The test of a set of wheels is had by placing them (when fitted on the axle) on a straight-edge, then placing a square on the straight-edge, with the tongue against the face of the spoke, which, if set plumb, will stand parallel with the tongue of the square. The space between parallel spokes on opposite wheels, when measured at the felly near the ground,

and on the same spokes near the hub, must be exactly alike. The usual resort to guess-work or diagram, repeated heating, hammering, measuring, and experimenting, does not produce satisfactory results, and a device which shall absolutely accomplish the purposes desired is almost a necessity to all wagon-manufacturers.

The object of the present invention is to provide an instrument of simple construction, which may be quickly applied to the wheels and axles, and by such application to at once, and with perfect and absolute accuracy, determine and provide for, first, taking the height and dish of the wheel; second, taking the taper of the spindle; third, setting the spindle for the dish; fourth, setting the spindle for the gather. The instrument is, in the hands of an intelligent workman, a practical calculator of angles. By its aid a set of tables can be established for varying taper, dish, and size of wheel, by setting two thumb-screws and simply noting changes on the graduated taper-taker, index-bar, and sliding rule.

The apparatus consists of a seven-eighths inch by one-quarter ($\frac{7}{8}$ by $\frac{1}{4}$) steel bar, A, six feet and three inches long; an index-bar, B, one inch by three-sixteenths (1 in. by $\frac{3}{16}$) in width and diameter, three feet nine inches long. This index-bar B is attached to main bar A, thirteen inches from the right-hand end, by a straight standard, K, which projects four inches from one edge and three inches from the other. A screw, *a*, passes through the center of this standard and through both bars A and B, serving as a pivot therefor. The gage-bar B, at its right-hand end, is attached to the main bar A by a slotted yoke, *b*, and set-screw *c*. A scale is cut on the face of the index-bar B, to adapt it for any sized wheel from two to five feet high. A vertical sliding rule, J, is applied on index-bar B, and is designed to show the dish, while the graduated scale on bar B shows the height of wheel. This sliding rule is provided with a double set of graduations, for the purposes as will hereinafter be fully indicated. A movable arm-rest, L, with curved ends projecting four inches from one edge and three inches from the other, is attached to the bar A near the right end. It is provided with a socket,

through which the bar A passes, and is secured at any point by a set-screw, *d*. This rest L is designed to support the gage in a true horizontal position over the center of the axle, in connection with the straight standard K, each resting on the opposite shoulders of the spindles, while the index-pointer of the taper-taker is placed over the end of the spindle that is to be set. To the taper-taker or graduated caliper is fitted a movable arm, *e*, having an adjusting set-screw, *e*¹, graduated scale *f*, and graduated sliding gage *g*, having set-screw *g*¹, and provided with an index-pointer, *h*, also with a depending projection, *i*. (See Fig. 2.) It is applied to and moved on the index-bar B by means of a socket, *k*, and held in position by means of a set-screw, *l*. A similar arrangement, three inches long, from which the adjustable gage-arm *e* is omitted, is applied in the same manner to arm A opposite. The side of the instrument provided with the short arms and short caliper is designated the "gather" side.

The application of the apparatus is as follows: To take half the height and dish of the wheel, as illustrated in Fig. 1, secure bars A and B parallel; place the apparatus on the wheel, the standard K on the left resting on the tire, the face or graduated side of index-bar B up, the bar A resting on the hub. Set the slide-rule J over the exact center of the hub, showing, on the scale on index-bar B, half the height of the wheel. Push the slide-rule J up until the top end thereof touches the face of the face-spoke, showing the dish of the wheel on the graduated scale on the left side of the slide-rule J. Then remove the instrument from the wheel without changing its position or the position of the slide-rule as set. Move the slide-rule up till its base presses the bottom of index-bar B; then release the thumb-screw, securing bars A and B parallel, and move bar B down till the graduated scale on the right-hand side of rule J shows the dish of the wheel from top edge of bar B to top edge of bar A. Secure the bar B in this position by means of the thumb-screw *c* and the slotted yoke *b*.

The apparatus is now set for a plumb spoke. To set under a plumb spoke, move bar B down from the point set as above whatever is desired; say, for one-eighth under, move down one-eighth of an inch, as indicated by the scale.

The apparatus is now ready for the application to bar B of the taper-taking device.

The taper of the spindle is taken as follows: The taper-taking device is first removed from the bar B. The axle-spindle is then calipered, as shown in Fig. 2, the apparatus being first applied at the shoulder and adjustable arm *e*, moved to the left until its depending arm *e*² presses upon the spindle, in which position it is secured by set-screw *e*¹. The point of the spindle is then calipered, the sliding graduated gage *g* being moved to the right until its face touches the spindle, pressing it against the lower point of the arm *e*² of the adjustable arm

e, the gage *g* being secured in this position by means of the set-screw *g*¹.

It may be here stated that the rear faces of both arms *e* and gage *g* are provided with a projecting tongue, which fits into a slot cut in the face of the body of the taper-taker—this for the purpose of guiding and controlling their position. After the taper of the spindle has been obtained, the taper-taker is replaced on the bar B. The apparatus is now ready for setting the axle-spindles. To set the spindles from the bottom, apply the gage as shown in Fig. 4, the long end of the standard K resting on the shoulder of the spindle that is to be set, the long end of the arm-rest L resting on the shoulder of the opposite spindle. The taper-taker is then moved out on the end of the bar B until the point *i* of the gage-arm *g* rests above the end of the spindle, the spindle then being bent until it conforms thereto. The instrument is then reversed, and the opposite spindle bent in a similar manner.

If it is desired to gather the axle, leave the slide-rule J in the same position as described in the first instance, after taking the dish of the wheel; then move bar B down from its parallel position with bar A until the scale on the right side of the slide-rule J indicates one-quarter the gather desired. Apply the instrument horizontally to the front of the spindle, as in Fig. 5, and bring the end of the spindle on a line therewith.

If it is desired to gather by the axle-spindle instead of by the wheel, set the short caliper (on the gather side of the instrument) as much less than the taper of the spindle as the gather desired. For instance, to set for an eighth gather, set the slide on the caliper one-eighth less than taper of the spindle, and set from the front of the spindle.

Example for working the gage: Given a four foot eight inch wheel, one inch dish, spindle one-quarter taper. The end of the spindle must be depressed one-quarter of an inch, as indicated by the gage, in four motions: First, place the apparatus on the axle; second, set slide-rule J on index-bar B at four feet eight inches, as per scale thereon; third, move bar B at this point down one inch, using the graduations on the right side of the rule J; fourth, set the index-pointer *h* on graduated caliper down one-quarter of an inch, (using scale *f*,) and the point *i* thereof indicates a needful change of one-quarter of an inch in order to secure a plumb spoke.

It will be noted that every quarter inch that the bar B is moved up or down gives one inch more width at the top than at the bottom of the wheel.

Having thus fully described my invention, what I claim as new, and desire to secure by Letters Patent, is—

1. In an axle set and gage, the combination of the main bar A, carrying adjustable bifurcated arm-rest L and bifurcated standard K, attached near its left-hand end, index-bar B, having a graduated scale cut on its face, the

two bars being secured together by means of a screw passing through both bars A and B, and the body of standard K forming a pivot on which bar B is oscillated, the movement of bar B being limited and controlled by means of slotted yoke *b*, attached to its right-hand end, and secured to bar A by thumb-screw *c*, bar B also carrying a sliding rule, J, provided with two sets of graduations, such arrangement being adapted for taking the height and dish of a wheel, as and for the purposes as herein shown and set forth.

2. In an axle set and gage, the combination of the main bar A, carrying arm-rest L and standard K, index-bar B, having a graduated scale on its face, and provided with sliding rule J, and a taper-taking or double calipering device, having a depending arm which indicates the point to which the spindle is to be set, such device being applied and adjusted upon the left-hand end of the bar B, beyond the point at which it is pivoted to the bar A, the whole arranged, applied, and operating substantially as and for the purposes as herein shown and set forth.

3. In an axle set and gage, the combination of the main bar A, carrying bifurcated arm-rest L and bifurcated standard K, index-bar B, having a graduated scale on its face, and carrying sliding rule J and a taper-taking or double calipering apparatus, and a graduated gage, *m*, carrying an adjustable arm, *n*, the point of which indicates the point to which the axle-spindle is to be set when gathering the

axle, the whole arranged, applied, and operating as and for the purposes as herein shown and set forth.

4. The taper-taking or double calipering device, consisting of a body provided with socket *k* and set-screw *l*, by means of which it is secured and adjusted on the index-bar of the axle-set, adjustable arm *e*, having depending finger *e*², sliding gage *g*, having depending arm *i*, the whole applied and operating as and for the purposes as herein shown and set forth.

5. The sliding rule J, provided with two sets of graduations, the scale on the right being in inches and divisions thereof, while the scale on the left is contracted one-eighth from the standard inch, such rule being adopted for use with an axle set and gage, in the manner as herein shown and set forth.

6. The short gage *m*, consisting of the body having on its face a series of graduations, and the adjustable sliding arm *n*, the point *o* of which is used, when attached by the main bar A of the axle-set, to indicate the point to which the axle-spindle is to be bent when setting the axle for the gather, substantially as and in the manner as herein shown and set forth.

In testimony that I claim the foregoing I have hereunto set my hand this 17th day of November, A. D. 1876.

WILLIAM C. CARLTON.

Witnesses:

SOL. HASBROUCK,
F. E. LOGAN.