

N. HARRIS.
Coffee-Roasters.

No. 196,225.

Patented Oct. 16, 1877.

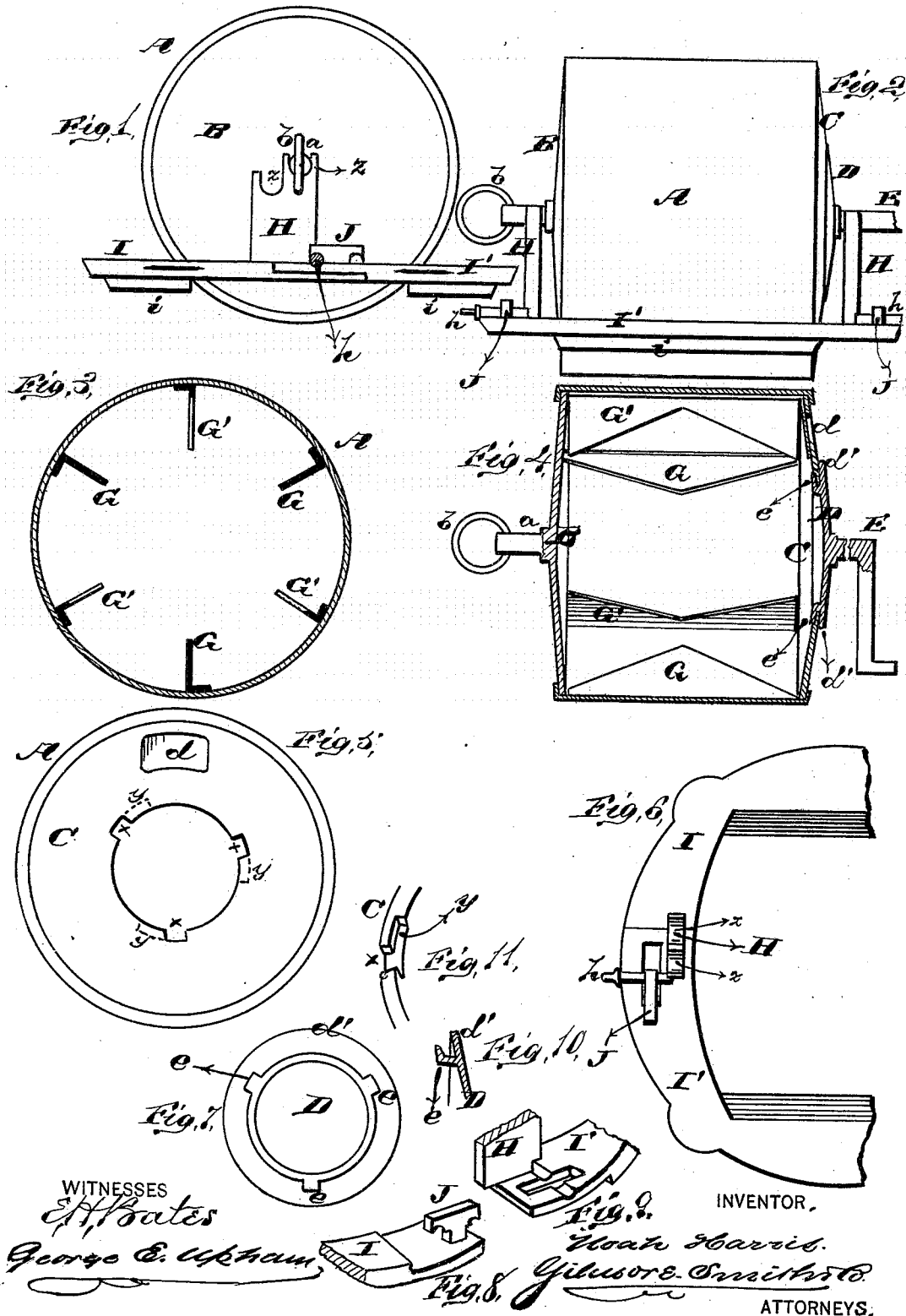

WITNESSES
E. Bates
George E. Upham

INVENTOR,
Nathan Harris.
Gilmore & Smith
ATTORNEYS.

UNITED STATES PATENT OFFICE.

NOAH HARRIS, OF XENIA, INDIANA.

IMPROVEMENT IN COFFEE-ROASTERS.

Specification forming part of Letters Patent No. **196,225**, dated October 16, 1877; application filed August 11, 1877.

To all whom it may concern:

Be it known that I, NOAH HARRIS, of Xenia, in the county of Miami and State of Indiana, have invented a new and valuable Improvement in Coffee-Roasters; and I do hereby declare that the following is a full, clear, and exact description of the construction and operation of the same, reference being had to the annexed drawings, making a part of this specification, and to the letters and figures of reference marked thereon.

Figure 1 of the drawings is a representation of a rear-end view of my coffee-roaster. Fig. 2 is a side view. Fig. 3 is a transverse vertical sectional view. Fig. 4 is a longitudinal vertical sectional view. Fig. 5 is a front view of the cylinder. Fig. 6 is a plan view of the frame. Fig. 7 is an inner view of the door. Figs. 8, 9, 10, and 11 are perspective details thereof.

The nature of my invention consists in the construction and arrangement of a coffee-roaster and stove-plate for supporting the same, as will be hereinafter more fully set forth.

The annexed drawing, to which reference is made, fully illustrates my invention.

The coffee-roaster proper is composed of a sheet-metal cylinder, A, and two cast-iron heads, B and C, fastened in said cylinder. The head B is entirely solid, and has a journal, *a*, projecting from its center; and in the end of said journal is a ring, *b*, to assist in lifting the drum from the stove.

The head C has, near one end, a mica-covered opening, *d*, through which the progress of roasting may be observed without opening the door of the drum.

In the center of the head C is a circular opening, of suitable dimensions, which is closed by means of a circular door, D. This door is formed with a circular overlapping flange, *d'*, and has projecting lugs *e e* on its inner side, which lugs pass through notches *x x*, and then, by turning the door to the right, said lugs pass under inclines *y y*, whereby the door becomes securely locked in place.

The door D is provided with an elongated crank, E, projecting from its center, as shown.

On the inner side of the drum A are secured longitudinal flanges G G', arranged in two alternating series. The flanges G G' are

made wider in the center and tapering toward both ends, and the flanges G' G' are wider at the ends and taper toward the center.

By the construction of these flanges it will be seen that during the process of roasting the flanges G throw the coffee toward the ends of the drum, while the flanges G' throw it from the ends to the center of the drum, thus changing the position of the coffee constantly during the process of the roasting.

The roaster thus constructed is supported in or on standards H H, which are cast upon a frame made in two parts, I and I'. The ends of these two parts are halved together and overlap each other. Each end of the part I is provided with a T-shaped button, J, which passes through a corresponding mortise in the end of the part I', and said part either pushed in or drawn out to come against the shank of the button, when the parts are held together by a pin, *h*, inserted under one end of the button.

There is a groove formed in the upper surface, near the end of the part I', for the pin to lie in; and the ends of the button are also grooved on their under sides for the same purpose.

It will readily be seen that the plate or frame I I' may be contracted or expanded, as required, and held by the pins *h* being inserted under either end of the buttons.

The standards H H are formed on the ends of the part I', and have each two bearings, *z z*, for supporting the journals of the roaster. These bearings are of different height, the lower ones being used when the plate is expanded, and the upper ones when it is contracted. On the under sides of the two parts of the stove-plate are curved or segmental flanges *i*, to project down into the stove-hole.

What I claim as new, and desire to secure by Letters Patent, is—

1. A drum or cylinder having secured to its inner surface longitudinal flanges G G', arranged in alternating series, the flanges G made wider in the center and tapering toward both ends, and the flanges G' wider at the ends and tapering toward the center, substantially as and for the purpose set forth.

2. A coffee-roaster composed of a sheet-metal cylinder, having attached thereto the

longitudinal alternating flanges G G' and two cast-iron heads, one of the heads having a central journal and a ring, and the other head having a mica-covered opening, substantially as and for the purposes set forth.

3. The frame herein described, consisting of the two parts I I', provided with T-shaped buttons J and standards H, and fastened together by the pins k, substantially as and for the purposes set forth.

In testimony that I claim the above I have hereunto subscribed my name in the presence of two witnesses.

NOAH HARRIS.

Witnesses:

V. M. BEAMER,
H. P. LOVELAND.