

G. A. CROSBY & G. W. WHITE.
Machines for Forming Barbs for Wire-Fences.

No. 196,290.

Patented Oct. 23, 1877.

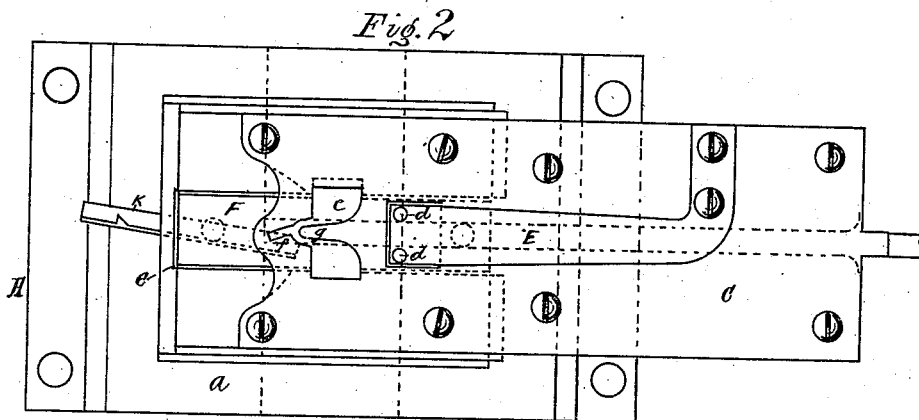
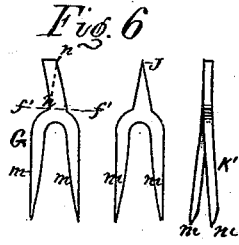
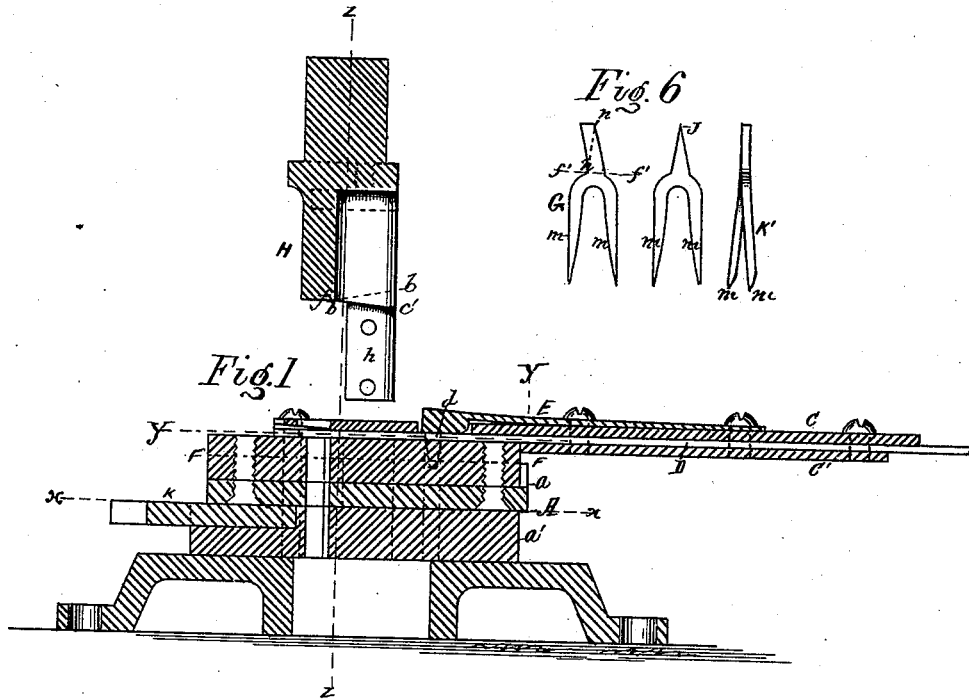

WITNESSES

N. Cross
A. J. Sherburne

INVENTOR

George A. Crosby
George W. White
By Guidley & Sherburne
attys

G. A. CROSBY & G. W. WHITE.
Machines for Forming Barbs for Wire-Fences.

No. 196,290.

Patented Oct. 23, 1877.

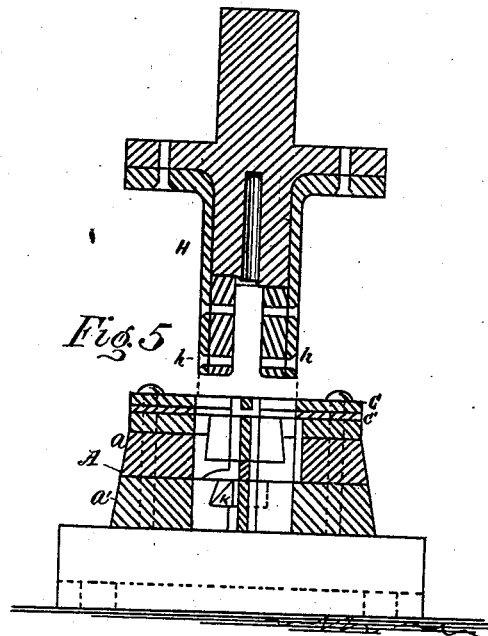
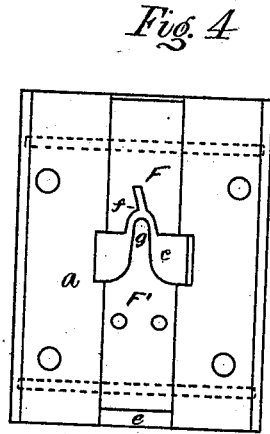
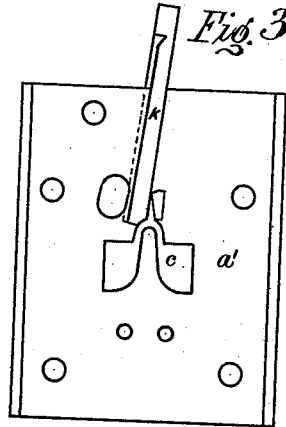

WITNESSES

N. Cowles
C. H. Sherburne

INVENTOR

George A. Crosby
George W. White
By Lindsey & Sherburne
Atty

UNITED STATES PATENT OFFICE.

GEORGE A. CROSBY AND GEORGE W. WHITE, OF CHICAGO, ILLINOIS; SAID
WHITE ASSIGNOR TO SAID CROSBY.

IMPROVEMENT IN MACHINES FOR FORMING BARBS FOR WIRE FENCES.

Specification forming part of Letters Patent No. **196,290**, dated October 23, 1877; application filed
August 6, 1877.

To all whom it may concern:

Be it known that we, GEORGE A. CROSBY and GEORGE W. WHITE, of Chicago, in the county of Cook and State of Illinois, have invented certain new and useful Improvements in Dies for Forming Barbs for Fence-Wire; and we do hereby declare the following to be a full, clear, and exact description thereof, which will enable others skilled in the art to which our invention appertains to make and use the same, reference being had to the accompanying drawings, forming part of this specification, in which—

Figure 1 represents a vertical longitudinal section of a barb-forming die embodying our said invention. Fig. 2 represents a general plan or top view of the same, with the male portion of the die removed. Fig. 3 represents a general plan of the same, taken on the line *x x* in Fig. 1. Fig. 4 represents a general plan of the same, taken on the line *y y* in Fig. 1. Fig. 5 represents a transverse sectional elevation, taken on the line *z z* in Fig. 1; and Fig. 6 represents the barb.

Like letters of reference indicate like parts.

Our invention relates to that class of dies employed in forming barbs from flat bar-iron; and the object of our invention is to provide a die which will complete the barb, as herein shown and described, at one operation, and to so arrange the several parts of the die as to render them capable of being easily repaired, should any part thereof become broken.

To that end our invention consists in the combination of the several parts, as is hereinafter more fully described and claimed.

In the drawing, A represents the base or body of the female portion of the die, which is made in two parts, *a a'*, secured together so that the part *a* will rest upon the part *a'*, as shown in Figs. 1 and 2. Each of said parts is provided, at a point near its center, with an opening, *c*, as shown in Figs. 3 and 4, and through which opening the barbs pass as they are formed.

C and C' are guide-plates, which are secured together and to the end of the part *a* of the die, and so as to project therefrom, as shown in Figs. 1 and 2. One or both of said plates are provided at their centers with a lon-

gitudinal groove or channel, through which the bar D, from which the barbs are formed, loosely passes. The arrangement of said groove is such as to allow the bar to be freely moved in the direction of its length, and so as to pass centrally over the opening *c*, as shown by dotted lines in Fig. 2.

E represents a flat metal spring, which is located longitudinally on the plate C and centrally over the groove, and is permanently attached at one end to the said plate, and is so arranged at the opposite end as to rest upon the bar D, as shown in Fig. 1, and is provided with depending guide pins or lugs *d d*, between which the said bar passes. The object of said spring is to hold the bar firmly upon the female portion of the die, and, at the same time, allow the bar to be moved in the direction of its length; and the object of providing the spring with the pins or lugs *d d* is to prevent the end of the bar from being displaced laterally as it is moved over the opening *c* in the part *a'* of the die.

F and F' are the die-blocks which form the female portion of the die proper, and are fitted into a longitudinal groove or channel, *e*, formed in the upper surface of the part *a*, and are secured therein by bolts or rivets passing laterally through them, and so as to allow them to be readily removed when desired. The end of the block F adjacent to block F' is provided with a recess, *f*, which corresponds in shape with the outer surface of that portion of the barb above the line *f'*, as shown at G, Fig. 6, and the end of the block F' adjacent to the block F is provided with a tongue, *g*, which corresponds in shape with the inner surface of that portion of the barb below the line *f'*, as shown in Figs. 2 and 4. H represents the male portion of the die, which is arranged to admit of being fitted into any suitable punching-machine, and is provided at its lower end with depending guides *h h*, adjusted to pass through the opening *c* in the parts *a a'* of the female portion of the die and on opposite sides of the tongue *g* of the die-block F', as shown in Fig. 5, and are of the proper distance apart to allow the bar D, from which the barbs are formed, to pass between them.

The face of the punch or die H corresponds

in shape with the barb, as shown at G, Fig. 6, and is so arranged as to pass into the recess *f* in the block F and on opposite sides of the tongue *g* of the block F' when forced downward by the action of the machine.

It will be observed, by reference to Fig. 6 of the drawing, that the projecting portion of the barb G above the line *f'* is made of a uniform width its entire length, and is arranged at an obtuse angle to the plane of the opposite points, the object of which is to leave the same of a proper size, so that the male portion of the die by which it is formed will contain the required amount of metal to stand the resistance of cutting the barb. To sharpen the said projecting portion so that it will be pointed, as shown at J, we provide a cutter, K, which is fitted into a groove in the part *a'*, as shown in Figs. 2 and 3, and so as to pass under the part *a*, as shown in Figs. 1 and 5. The cutting-edge of this cutter is so arranged as to pass across the corner of the recess *f*, as shown by dotted lines in Fig. 2, and so as to cut off the corner of the projecting end of the barb on the line *n n*, as shown in Fig. 6, as the barbs are forced through the die-blocks.

To secure the barbs upon the wire, in the construction of wire fences, the wire is passed into the recess between the parts *m m* of the barb proper, and the said parts bent so as to cross each other and so as to clamp the wire, and in order to facilitate the attaching of the barbs to the wire it becomes necessary, in the forming of the barb, to bend the said parts *m m* in opposite directions laterally, so that they will readily pass each other when bent to clasp the wire. To accomplish this we form the

faces of the male portion of the die which cut the said parts *m m* at an angle to each other, as shown by the lines *b b* and *b c'*, Fig. 1, and so as to bend the said parts *m m*, as shown at K', Fig. 6, at the time the barbs are cut from the bar.

We have described the die-blocks F and F' as being so arranged as to admit of being removed when desired, the object of which is to allow them to be readily removed for repair, should they become worn, or to allow them to be removed and new ones substituted should they become broken, and thereby obviate the necessity of rebuilding the entire female portion of the die.

Having thus described our invention, what we claim as new, and desire to secure by Letters Patent, is—

1. The combination, with the die-blocks F and F' and punch H, of the supplemental cutter K, substantially as and for the purpose specified.

2. The combination, with the die-blocks F and F', of the grooved guide-plates C, C', and spring E, substantially as and for the purpose specified.

3. The combination, with the die-blocks F and F', of the male die H, provided with the guides *h h*, and having the faces of the wings of the die arranged at different angles, so as to bend the parts *m m* of the barbs, substantially as and for the purpose specified.

GEORGE A. CROSBY.
GEORGE W. WHITE.

Witnesses:

N. C. GRIDLEY,
N. H. SHERBURNE.