

A. J. NELLIS.
Molds for Casting Steel.

No. 196,307.

Patented Oct. 23, 1877.

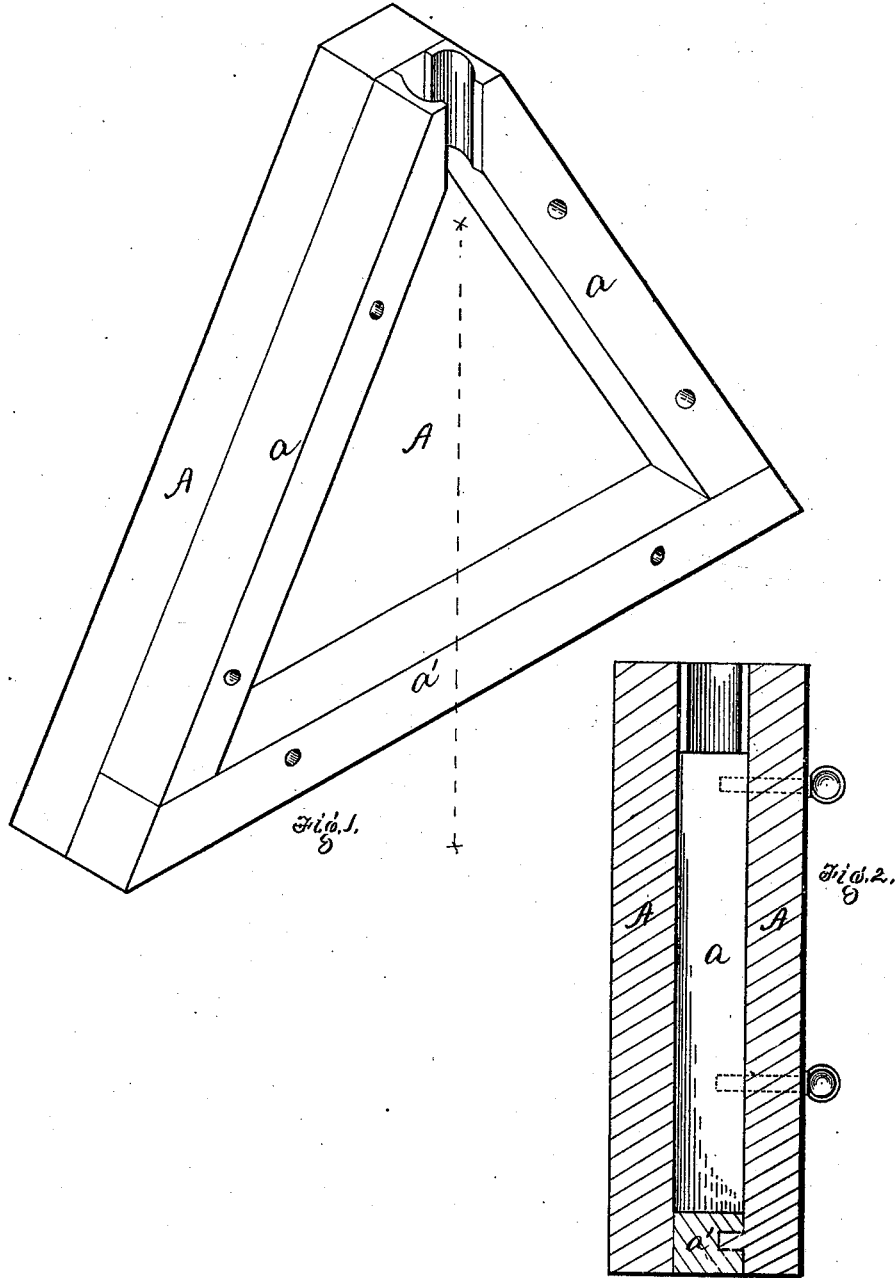

WITNESSES.
John Smith
R. C. Winchall

INVENTOR.
Aaron J. Nellis
By Bakerwell & Kern
Attys

UNITED STATES PATENT OFFICE.

AARON J. NELLIS, OF PITTSBURG, PENNSYLVANIA.

IMPROVEMENT IN MOLDS FOR CASTING STEEL.

Specification forming part of Letters Patent No. **196,307**, dated October 23, 1877; application filed August 10, 1877.

To all whom it may concern:

Be it known that I, AARON J. NELLIS, of Pittsburg, in the county of Allegheny and State of Pennsylvania, have invented a new and useful Improvement in Molds for Casting Steel; and I do hereby declare the following to be a full, clear, and exact description thereof, reference being had to the accompanying drawing, forming part of this specification, in which—

Figure 1 is a perspective view of a mold embodying my invention, one side being removed to show the interior. Fig. 2 is a sectional view.

Like letters refer to like parts wherever they occur.

My invention relates to the construction of molds especially adapted for the casting of cast-steel articles.

The objections to iron molds are, first, that whenever any joints or corners occur the casting adheres, and in cooling will not contract evenly; and, secondly, the air and gases have no ready vent.

The objections to sand molds are the lack of durability, and the difficulty of obtaining perfect molds, and, also, the necessity of drying the sand thoroughly, which requires considerable time, especially if the mold is large.

The object of the present invention is to obtain a mold readily repaired and kept in order—one which will have the advantages of both the sand and metal mold, without the disadvantages of either, and will permit the contracting of the casting, so as to obtain perfect articles.

I will now proceed to describe my invention, so that others skilled in the art to which it appertains may apply the same.

In the drawing is represented a mold, partly of iron and partly of sand. The larger portions of the mold A A, or sides, are formed from iron, in the usual manner, and the ends or intervals *a a* are filled with sand cores to complete the mold. The sections or cores *a a* are made from sand, ashes, loam, &c., or any

other suitable core material, and are shaped to the requirements of the position they occupy in a mold, being dried and prepared in the manner and by the means well known in the art.

In a mold of such or similar form, two cores or sides, *a a*, being formed of sand, will give sufficient surface for the escape of gases, and will permit the casting to contract; therefore, the remaining section *a'* may be made of either iron or sand, as preferred. A mold of any desired form may be thus made in alternate sections of metal and sand, the rule to be observed being that, wherever corners or pockets occur in the mold, the sand and metal should meet, giving one material from which the casting can free itself in contracting, there being no tendency of the casting to adhere to plain surfaces, but only in corners or pockets, and where it is apt to cut in pouring. The metallic sections are generally formed separately, and connected to the core-sections of the mold by pins, bolts, &c.

The advantages of a mold constructed in accordance with my invention are, first, that it is rapidly and readily repaired; and, secondly, that it insures a good casting.

Having thus described my invention, what I claim, and desire to secure by Letters Patent, is—

1. A mold composed of metallic sections and intermediate separate and detachable sections formed of core material, substantially as and for the purpose specified.

2. A mold composed of metallic sections and intermediate separate and detachable sections formed of core material, with suitable means for at once connecting the metallic and supporting the core sections, substantially as and for the purpose specified.

In testimony whereof I, the said AARON J. NELLIS, have hereunto set my hand.

AARON J. NELLIS.

Witnesses:

F. W. RITTER, Jr.,
JNO. K. SMITH.