

W. B. & R. BARTON.
Cigar Machine.

No. 196,553

Patented Oct. 30, 1877.

Fig. 1.

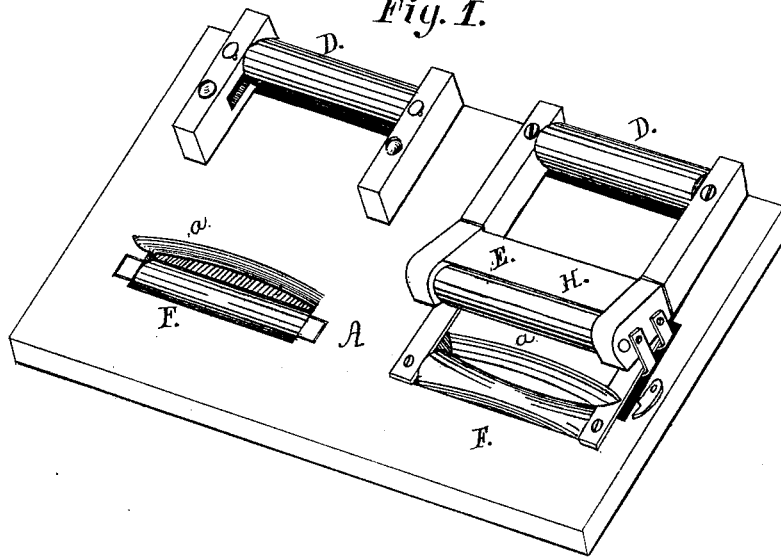
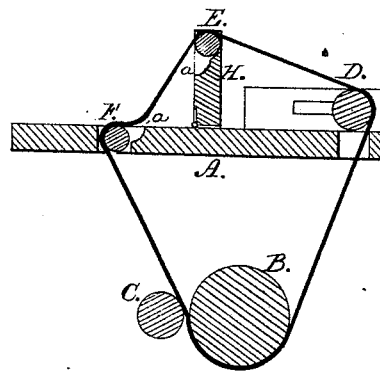

Fig. 2.



WITNESSES

Barker H. Sweet Jr.
W. S. Birch.

INVENTOR

William B. Barton
Richard Barton
J. P. Rice ATTORNEY

W. B. & R. BARTON.
Cigar Machine.

No. 196,553

Patented Oct. 30, 1877.

Fig. 3.

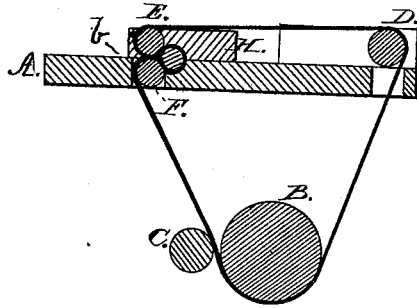

Fig. 4.

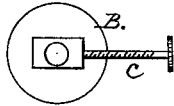

Fig. 5.

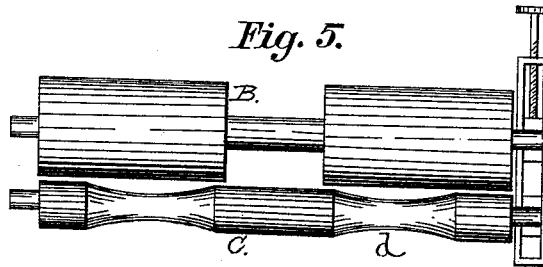

Fig. 7.

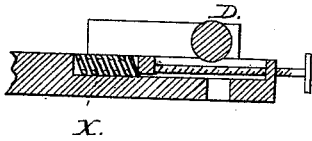

Fig. 6.

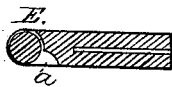
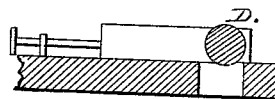

Fig. 8.



WITNESSES
Frank H. Sweet, Jr.
W. B. Barton

INVENTOR
William B. Barton
Richard Barton
John Danvers ATTORNEY

W. B. & R. BARTON.
Cigar Machine.

No. 196,553

Patented Oct. 30, 1877.

Fig 9.

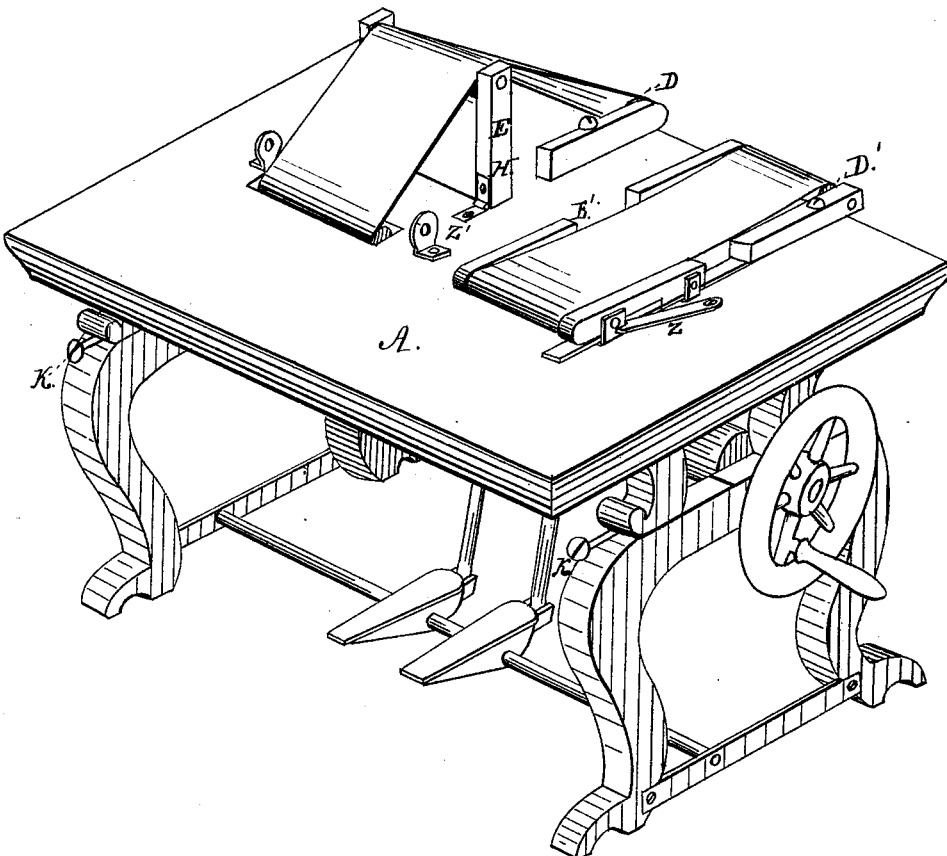

Witnesses.
 Parker H. Sweet Jr.
 W. P. Birch

Inventor.
 William B. Barton
 Richard Barton
 J. C. Dane Jr.
 Atty.

UNITED STATES PATENT OFFICE.

WILLIAM B. BARTON AND RICHARD BARTON, OF NEW YORK, N. Y.

IMPROVEMENT IN CIGAR-MACHINES.

Specification forming part of Letters Patent No. **196,553**, dated October 30, 1877; application filed October 20, 1876.

To all whom it may concern:

Be it known that we, WILLIAM B. BARTON and RICHARD BARTON, both of the city, county, and State of New York, have invented certain new and useful Improvements in Machines for the Manufacture of Cigars; and we do hereby declare that the following specification, taken in connection with the drawings furnished, is a full, clear, and exact description thereof, which will enable others skilled in the art to make and use the same.

Our invention relates to improvements in machines for the manufacture of cigars, and especially to such as will completely form and finish them at one operation without the aid of skilled labor; and it consists of a band or an endless apron arranged to move in one continuous direction, acting in conjunction with a "form," one portion of which being arranged within the table, the other within a movable carriage above, within which the cigar is formed and ejected automatically; and it consists, further, of suitable mechanism for transmitting motion to said band, and for the prevention of folds and wrinkles in the latter, and for the application of the necessary tension thereto for regulating the degree of hardness desirable in the cigar to be thus formed.

Referring to the drawings, Figure 1 represents a perspective view of the tops of the tables, exhibiting the tension devices and a portion of the form within which the band or apron moves while forming the cigar or other similar articles. Fig. 2 is a vertical longitudinal section of our invention. Fig. 3 represents a similar view, with a movable carriage and band in position as in the act of forming the cigar; Fig. 4, end view of the drum B, with adjustable screw *c* in position; Fig. 5, top-plan view of drum and tender, with adjusting-screw for forcing them together. Fig. 6 represents a vertical longitudinal section of a carriage, H, showing a roller, E, in position, and its proper relation to the form *a* therein. It also shows a groove or channel for the admission of a fixed tongue, which admits of the carriage being reciprocated back and forth horizontally instead of swinging upon hinges, as shown in Fig. 2, of which this is intended as a modification. It is, of course, obvious that the carriage or

frame H may be moved or operated in many different ways to bring it to and from the counterpart of the form *a*. Figs. 7 and 8, detailed views of tension devices, one exhibiting the means for adjustment in the rear of the journals of the roller D, the other at the front. Fig. 7 also exhibits a spring, X, so arranged as to serve to apply tension to the moving apron automatically through the roller D; Fig. 9, a perspective view of the complete machine.

Similar letters of reference occurring on the several figures indicate like parts.

A is a table, provided, in this instance, with a form or a receptacle for a cigar of the contour of the same; and arranged over the table is a frame, H, hinged, sliding, reciprocating vertically, or otherwise held or operated so as to be brought over the cavity *a*, when desired, and in it is a counterpart, *a*, of the form.

D is a tension device having a roller supported in an adjustable frame, against which the endless band or apron turns or rests, as shown in Figs. 2, 3, and 9, serving as the means for regulating the tension of the band, and thereby the degree of hardness of the cigar, which adjustment is accomplished by a screw, as shown, or other equivalent means.

E and F are concave rollers arranged at the front of the form, and thereby forming one side thereof—to wit: one in the table at F, the other in the movable carriage H at E, as shown in Figs. 1, 2, and 3 of the drawings.

B is a drum or pulley serving as the driver for transmitting motion to the band or endless apron, which apron is more fully shown in Figs. 2 and 3 of the drawings, which passes, over the outside of the tension-roller D, to and over the fronts of the rollers E and F, before referred to. (See Figs. 2, 3, and 9.)

The rollers last referred to serve to guide the endless apron, which insures to it steady action with a very limited amount of friction in its passage within the form, which, as it were, forms a complete lining, and which completely incloses the cigar undergoing the process of formation, which is very clearly represented in Fig. 3 of the drawings.

C is a secondary drum, which we term a "tender," so located and arranged that it may be crowded or forced against the apron and

drum B, which serves to prevent the folding and wrinkling of the band while passing into and out of the form while making the cigar. This tender also serves to prevent the slipping of the endless apron while in operation. The tender has alternate cylindrical and concave parts C and *d*, the former for forming the bite upon the rigid edges of the apron, and the latter for leaving the elastic part of the apron free.

We have represented the drum B as adjustable toward the tender C, in Fig. 5, although it is obvious that the tender may be moved as readily, and have so represented the same in Fig. 9 of the drawings, which adjustment may be accomplished by screw K K, or by other suitable means.

We would remark, however, that springs might be interposed to operate with elastic pressure against the journals of either of the drums, and thereby apply pressure automatically.

We employ a band having edges more or less rigid, its center elastic, so that it may readily yield to the shape of the form within which it traverses while in the process of forming the cigar.

In practice we usually adopt hair-cloth for the center and linen for its edges, although the combination of other materials embodying the same features of elasticity or non-elasticity will serve in lieu thereof.

The carriage H, provided with a portion of the form *a*, which acts above the table, is constructed to be held in a fixed position by catches while the cigar is being formed, which catches are more fully shown in Fig. 9 of the drawings, engaging projections upon the carriage.

We would also remark that a connection with the carriage, by means of cord or otherwise, operated by the foot, to secure the upper part of the form in position while forming the cigar, allows the operator free use of his or her hands, which is desirable, especially in factory use.

It will be seen that when the frame H is brought down or forward into position for operation, the form *a* is made complete by the contact of the two cavities. There will be in the front of the form, and between the rollers E and F, a mouth or opening, *b*, through which the apron passes to and from the form upon one side only.

Great advantages arise in manufacturing cigars by this construction and arrangement, as well as by having the rollers formed and situated as shown.

We do not limit ourselves to the precise formation of the several parts which we have shown and described, as we propose to employ any modification in the construction and arrangement of the several parts which will serve to act and produce a cigar in the same, or substantially the same, manner as herein described.

To produce a cigar, we take the quantity of material requisite for a given size, and, by a slight roll or twist given to it by the hand of the operator, place it against the moving band or apron, with a gentle pressure, at a point between the two rollers E and F, (see Fig. 2,) which forms the front of the receptacle, which will form a bight to receive and hold the material within the form. When the carriage is moved into position, as shown in Fig. 3 of the drawing, by swinging or sliding, and as the apron continues its motion, the material is revolved and thereby twisted or rolled into the desired shape at once, the wrapper being applied by inserting one end of it within the opening or bight between the rolls, as in Fig. 3, and lap of the apron, the action of which carries the wrapper around the body of the cigar, where it is held secure by the same means employed in their manufacture by hand. When completed the moving of the carriage out of its fixed position releases the apron from the form, which action ejects the cigar automatically.

What we claim, and desire to secure by Letters Patent, is—

1. The endless apron having a flexible or elastic center and rigid edges, substantially as and for the purpose set forth.
2. The combination of the apron constructed as described and a cigar-forming cavity for holding the material for the cigar, as set forth.
3. The combination of the apron constructed as described, the cigar-holding and forming-cavity, and rolls E F, and frames H A, as set forth.
4. The combination of an endless band, frames H A, provided with cigar-forming cavities *a a*, and rollers E F, constructed as described.
5. The combination of an endless apron, frames H A, provided with cigar-forming cavities *a a*, and rolls E F, driving-roll B, and the tender C *d*, substantially as set forth.
6. The combination of an endless apron, frames H A, provided with cigar-forming cavities *a a*, and rollers E F, the drum B, and the tension device D, substantially as and for the purpose set forth.
7. The combination of an endless apron, frames H A, provided with cigar-forming cavities *a a*, and rolls E F, drum B, and the tender C, as described, and the tension device, as set forth.
8. The combination of an endless apron, frames H A, provided with cigar forming and holding cavities *a a*, and rolls E F, the frame H being hinged or pivoted, and the drum B, substantially as set forth.
9. The endless apron herein described, in combination with the movable and stationary frames H A, provided with cigar forming and holding cavities *a a*, and rollers E F, the drum B, concave tender C, tension device D, constructed substantially as described.
10. The combination of frames H A, one

movable, the other stationary, having cavities *a a*, the rollers E F, and the endless apron, in the manner substantially as described, by virtue of which the belt passes into and out of the cigar forming and holding cavity at the same point, substantially as set forth.

In testimony that we claim the foregoing we have hereunto subscribed our names, in the

presence of the witnesses whose names hereunto appear, on the 25th day of September, A. D. 1876.

WM. B. BARTON. [L. S.]
RICHARD BARTON. [L. S.]

Witnesses:

JOHN DANE, Jr.,
JOSEPH CRANES.