

W. KEYS.
Horseshoe-Nail Machines.

No. 196,585

Patented Oct. 30, 1877.

Fig. 1.

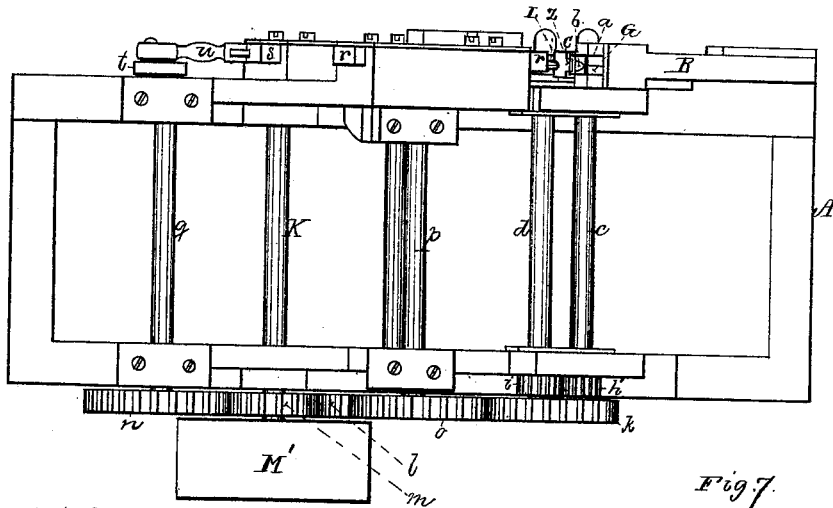

Fig. 6.

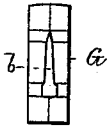

Fig. 7.

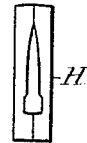
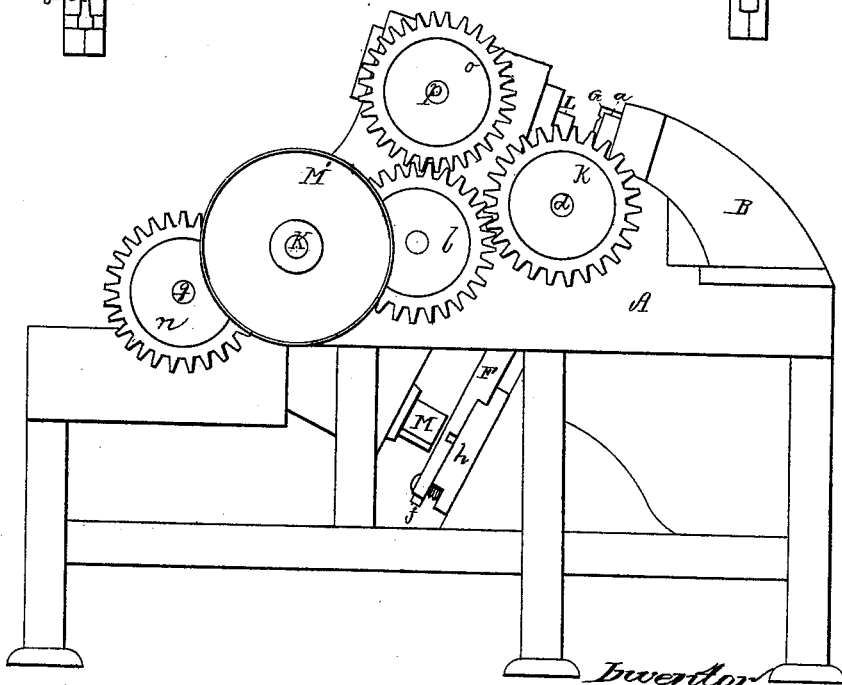

Fig. 2.



Witnesses
S. W. Piper
L. S. Miller

Inventor
William Keys.
 by his attorney
R. H. Eddy.

W. KEYS.
Horseshoe-Nail Machines.
No. 196,585
Patented Oct. 30, 1877.

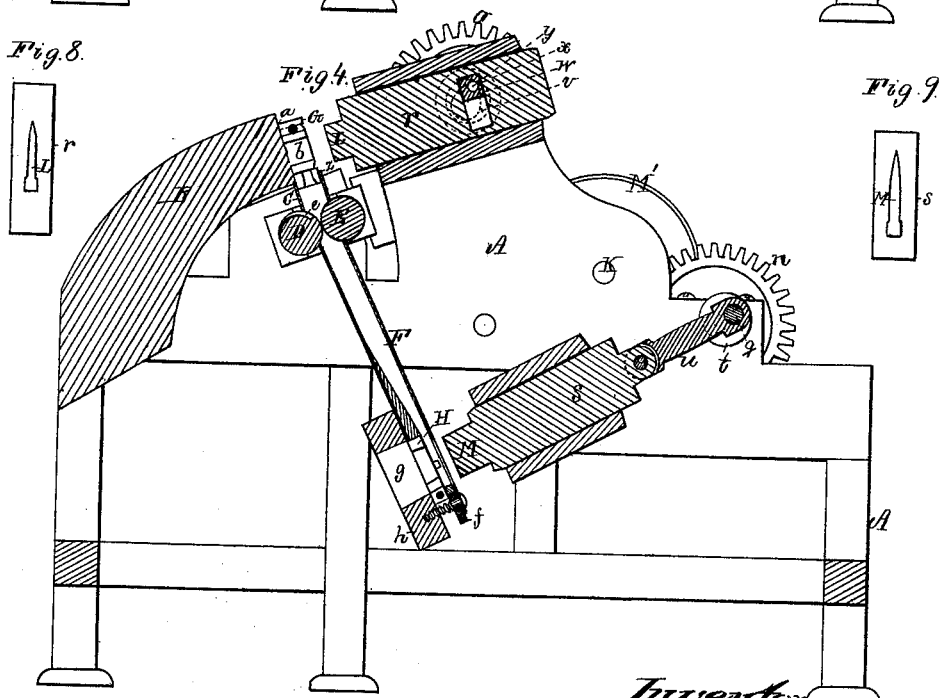
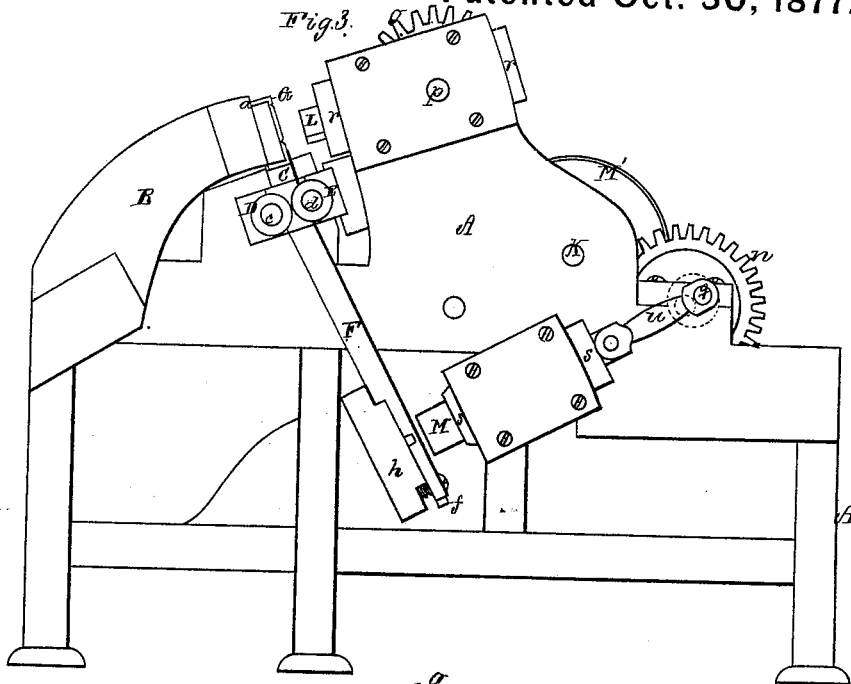

Witnesses
S. W. Piper
L. G. Miller

Inventor
William Keys
by his attorney
R. H. Eddy

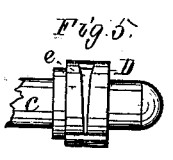

UNITED STATES PATENT OFFICE.

WILLIAM KEYS, OF MONTREAL, QUEBEC, CANADA, ASSIGNOR TO LUCY J. M. HUTCHINS, OF SAME PLACE.

IMPROVEMENT IN HORSESHOE-NAIL MACHINES.

Specification forming part of Letters Patent No. **196,585**, dated October 30, 1877; application filed August 21, 1877.

To all whom it may concern:

Be it known that I, WILLIAM KEYS, of the city of Montreal, of the Province of Quebec, of the Dominion of Canada, have invented a new and useful Machine for Making Horse-shoe-Nails; and do hereby declare the same to be described in the following specification and represented in the accompanying drawings, of which—

Figure 1 is a top view, and Figs. 2 and 3 opposite side elevations, of it. Fig. 4 is a vertical section taken through the dies and rolls for forming, tapering, and pointing the blank, as will be hereinafter described. Fig. 5 is a top view of the recessed swaging-roll. Figs. 6 and 7 are views of the female dies, and Figs. 8 and 9 are end views of the male dies, used in such machine.

With the said machine a nail-blank is first punched from a thin metallic plate, and falls into a spout, by which it is conducted to the bite of a pair of swaging-rolls, by whose action it is swaged and tapered in thickness. From the said rolls it passes into another conduit, through which it falls down to and in front of the female shaping and pointing die, through which and from the machine it is next forced by the fellow or male die, and by the two is finished in shape and has its point completed.

My invention consists in the machine or combination, substantially as hereinafter explained, consisting of blank-forming dies, swaging-rolls, spouts or conductors, an adjustable shoulder or shelf, and finishing-dies, arranged and provided with operative mechanism, as set forth.

In the drawings, A denotes the frame of the machine. Within an arm, B, extending up from such frame there is placed in a socket, *a*, in the said arm the female die G for forming the blank, such die being chambered, as shown at *b*. The chamber opens into a short spout, C, leading to the bite of two rolls, D E. These rolls are fixed on separate shafts *c d*, arranged in suitable bearings in the frame A. The roll D is recessed, as represented at *e*, to receive the blank, and, with the roll E, to taper it and reduce it properly in thickness, and bevel it while it may be passing between them, (the

said rolls.) Extending down from the bite of the rolls is an inclined conductor or spout, F, leading to a female die, H, such spout being provided with an adjustable shoulder or bottom piece, *f*, to arrest the descent of the nail-blank. In rear of the said die H is a passage, *g*, leading through the projection *h*, by which the die is supported.

The male dies or punches for the two female dies G H are shown at L and M as projecting from the ends of two slides or carriers, *r s*. The two roll-shafts *c d* have fixed upon them two connecting-gears, *h' i*, there being also on one of such shafts a driving-gear, *k*, which engages with a transmitting-gear, *l*, that, in turn, engages with another gear, *m*, fixed on the main driving-shaft K of the machine, all being arranged as represented. The said gear also engages with two other gears, *n o*, fixed on separate shafts *p q*, provided with mechanism for imparting to the two male-die carriers *r s* their reciprocating rectilinear motions. Such mechanism for one of such shafts is a crank-wheel, *t*, and a connecting-rod, *u*, the latter being pivoted to the carrier *s* and to the wrist of the crank-wheel.

For actuating the upper die-carrier *r*, it has a straight slot, *v*, made through it transversely. In this slot is a slide, *w*, provided with a cylindrical hole, *x*, to receive the wrist of a crank, *y*, fixed on the shaft *p*. During each revolution of the said shaft the die-carrier will be advanced and retracted. At the upper end of the spout C there is a projection, Z, upon which the lower edge of the nail-plate rests while being punched by the die L. The main shaft K is furnished with a driving-wheel, M', to receive a belt from some proper motor. On the said wheel being revolved, the various movable members of the machine will be put in motion. The nail-plate will have a nail-blank punched from it and forced through the upper female die into the chamber thereof, from which such blank will fall into the short spout C, and by it be conducted to and between the swaging-rolls. These latter will seize the blank and reduce or taper it in its thickness. From the said rolls the blank will fall into and through the conductor F, to and

between the lower dies, by which it will next be finished, or have its surplus metal removed from it.

I do not claim a machine made as shown in the United States Patent No. 190,011, which, in some respects, is analogous to that hereinbefore explained, though differing in various essential particulars, my machine being much simpler and different in construction, and operating in a different manner to make a nail.

I have no presser to hold in a die the nail-blank by its head; nor have I any clearer, funnel-shaped guide, spring-fork fingers, or various other devices which are essential to the said machine. In my machine the nail-blank, after being severed from the plate by the dies G L, drops into an inclined spout, C, and thence between the swaging-rolls, after which it passes between such rolls, and thence into

and down another spout to the adjustable shoulder *f*. It is next, by the male projecting die, driven through the female finishing-die and expressed from the machine.

I claim—

The improved machine, substantially as specified, consisting of the blank-forming dies G L, swaging-rolls D E, two spouts, C F, adjustable shoulder or shelf *f*, and the finishing-dies H M, arranged and combined as described, and provided with mechanism for revolving the swaging-rolls, and also with mechanism for actuating the movable dies L M, all being as set forth.

WM. KEYS.

Witnesses:

R. H. EDDY,
JOHN R. SNOW.