

P. SEITZ.
Sugar-Cane Harvester.

No. 196,598

Patented Oct. 30, 1877.

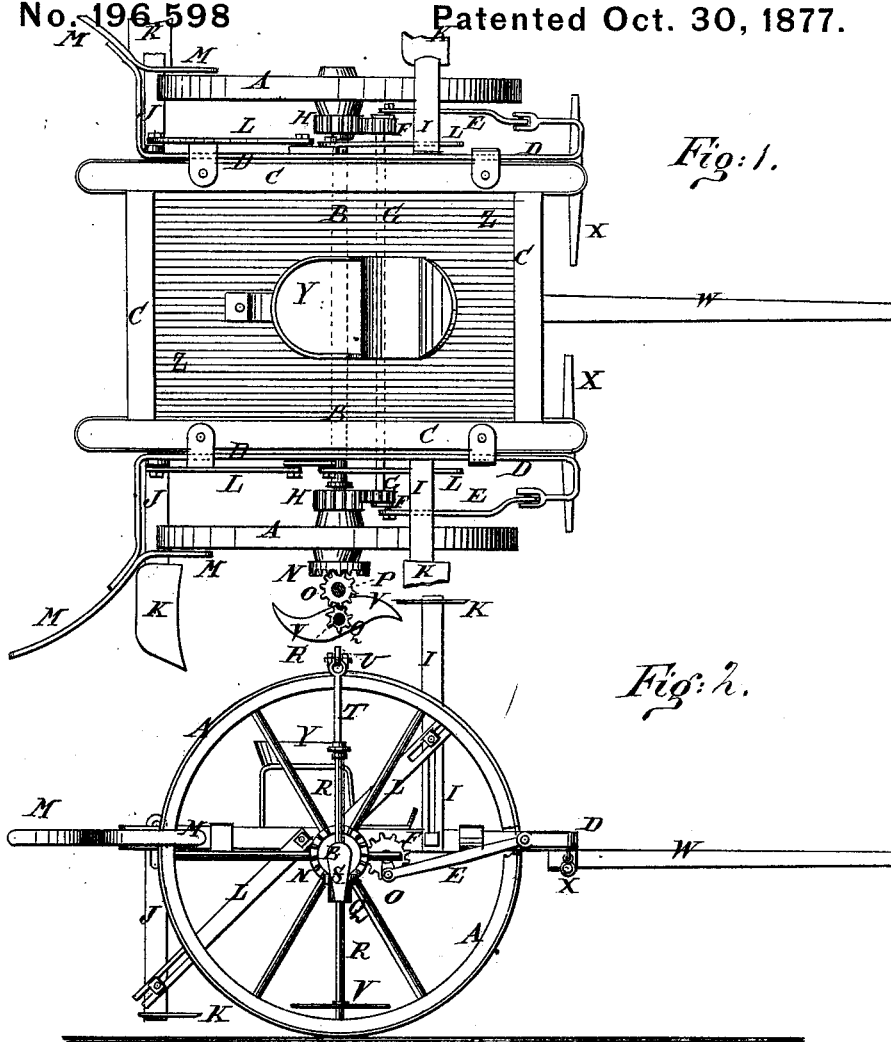

Fig: 1.

Fig: 2.

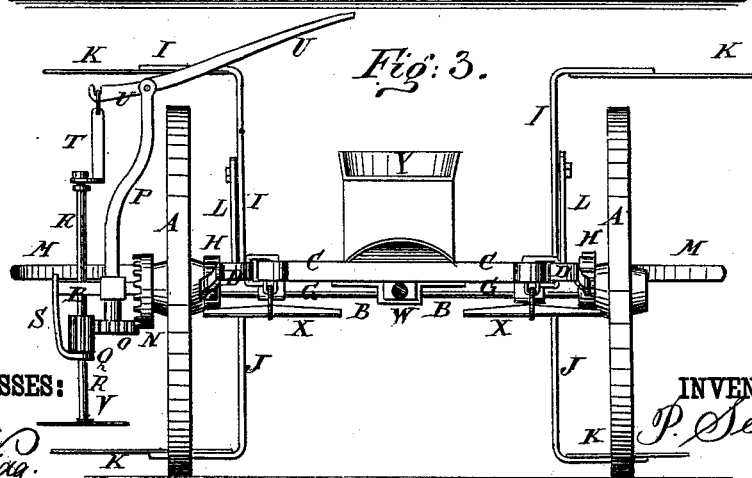

Fig: 3.

WITNESSES:

Chas. N. ...
J. H. Scarborough.

INVENTOR:

P. Seitz

BY

Wm. ...
ATTORNEYS.

UNITED STATES PATENT OFFICE.

PHILIP SEITZ, OF BATON ROUGE, LOUISIANA, ASSIGNOR TO HIMSELF AND
J. C. HOLT, OF SAME PLACE.

IMPROVEMENT IN SUGAR-CANE HARVESTERS.

Specification forming part of Letters Patent No. **196,598**, dated October 30, 1877; application filed
June 18, 1877.

To all whom it may concern:

Be it known that I, PHILIP SEITZ, of Baton Rouge, in the parish of East Baton Rouge and State of Louisiana, have invented a new and useful Improvement in Sugar-Cane Cutters, of which the following is a specification:

Figure 1 is a top view of my improved machine. Fig. 2 is a side view of the same. Fig. 3 is a front view of the same.

Similar letters of reference indicate corresponding parts.

The object of this invention is to furnish an improved machine designed especially for cutting sugar-cane, but which may also be used for cutting corn and cotton stalks and stubble, and which shall be simple in construction, convenient in use, and effective in operation.

The invention consists in the combination of the sliding bars, the connecting-bars, the gear-wheels, the adjustable bars that carry the knives, and the adjustable braces with each other, and with the wheels and the frame of the machine; in the combination of the guide-bars with the outwardly-projecting rear ends of the sliding bars; and in the combination of the gear-wheels, the rod, the shaft, the bar, the lever, and the cutters with the wheels and axle of the machine, as hereinafter fully described.

A are the wheels, which revolve upon the journals of the axle B. The axle B is attached to the frame C, and may be made in two parts, so that it may be contracted and expanded to adjust it for narrower or wider rows. D are bars placed at the outer sides of the side bars of the frame C, and sliding in keepers attached to the said side bars. The forward parts of the bars D are bent outward into U form, and to their ends are pivoted the ends of the connecting-bars E, the rear ends of which are pivoted to the crank-pins of the small gear-wheels F, attached to the ends of the shaft G. The shaft G revolves in bearings attached to the frame C. The teeth of the small gear-wheels F mesh into the teeth of the larger gear-wheels H, attached to or formed upon the inner ends of the hubs of the wheels A, so that the slide-bars D may receive a reciprocating longitudinal movement from the advance of the machine. To each of the sliding bars D, in front

of the axle B, is bolted the lower end of an upwardly-projecting bar, I, and to the said sliding bar D, in the rear of the said axle B, is bolted the upper end of the downwardly-projecting bar J. The free ends of the bars I J are bent outward at right angles, and to them are bolted the knives or cutters K. The bars I J are slotted to receive the bolts that secure them to the bars D, so that they may be adjusted to bring the knives or cutters K nearer to or farther from the ground, according to the height of the cane. The bars I J are strengthened against the draft-strain by the braces L, the outer ends of which are bolted to the bars I J, and their inner ends are bolted to the middle part of the bar D. The outer parts of the braces L are slotted longitudinally, to receive the bolts that secure them to the bars I J, to allow the said bars I J to be adjusted.

By this construction, as the machine is drawn forward, the upper knives K first meet the cane and cut off their tops, and then the lower knives meet and cut off their bottoms.

The rear ends of the sliding bars D are bent outward at right angles, and to their outer ends are attached bars or arms M, the forward parts of which project along the outer side of the wheels A. The other ends of the bars or arms M curve outward and rearward, as shown in Fig. 1, so that as the cane-stalks are cut and fall back the bars M guide them into the next furrow. To the outer ends of the hubs of the wheels A are attached crown or bevel-gear wheels N, the teeth of which mesh into the teeth of the small gear-wheel O, pivoted to the lower end of the rod P, which has a hole formed through it to receive and ride upon the projecting end of the axle B. The teeth of the gear-wheel O mesh into the teeth of the long gear-wheel Q, attached to the shaft R, which passes through and revolves in a hole in the axle B, and in an arm, S, attached to the end of said axle. The upper end of the shaft R is swiveled to the lower end of a bar, T, the upper end of which is pivoted to the end of the lever U. The lever U is pivoted to the upper end of the rod P, and its upper end projects into such a position that it may be reached and operated by the driver with his hand or with

his foot, as may be desired. To the lower end of the shaft R is attached a knife, V, which may be straight, curved, or circular, and which is designed to be used for cutting off cane-stalks when it is desired to windrow them, and for cutting off corn-stalks, cotton-stalks, stubble, &c. W is the tongue, which is attached to the forward part of the frame C. X are the whiffletrees, which are attached to the forward corners of the frame C. Y is the driver's seat, which is attached to the frame C, or to a platform, Z, attached to said frame.

I am aware that it is not, broadly, new to provide a corn-harvester with horizontally-revolving knives for cutting off corn-stalks near the ground, and to combine with said cutters or knives means for raising and lowering the same.

Having thus described my invention, I claim as new and desire to secure by Letters Patent—

1. The combination of the sliding bars D,

the connecting-bars E, the gear-wheels F H, the adjustable bars I J, that carry the knives K, and the adjustable braces L, with each other, and with the wheels A and frame C, substantially as herein shown and described.

2. The combination of the guide-bars M with the outwardly-projecting rear ends of the sliding bars D, substantially as herein shown and described.

3. The combination, in a cane-cutter, of the vertically-adjustable shaft R, horizontal cutter V, long pinion Q, and swivel bearing-bar T with the gear-wheels O N, supporting-bar P, lever U, and the wheel and axle A' B, as and for the purpose set forth.

PHILIP SEITZ.

Witnesses:

JOS. GEBELIN,
W. P. BATES.