

J. W. TUTEWILER.
Fire-Escape.

No. 196,607

Patented Oct. 30, 1877.

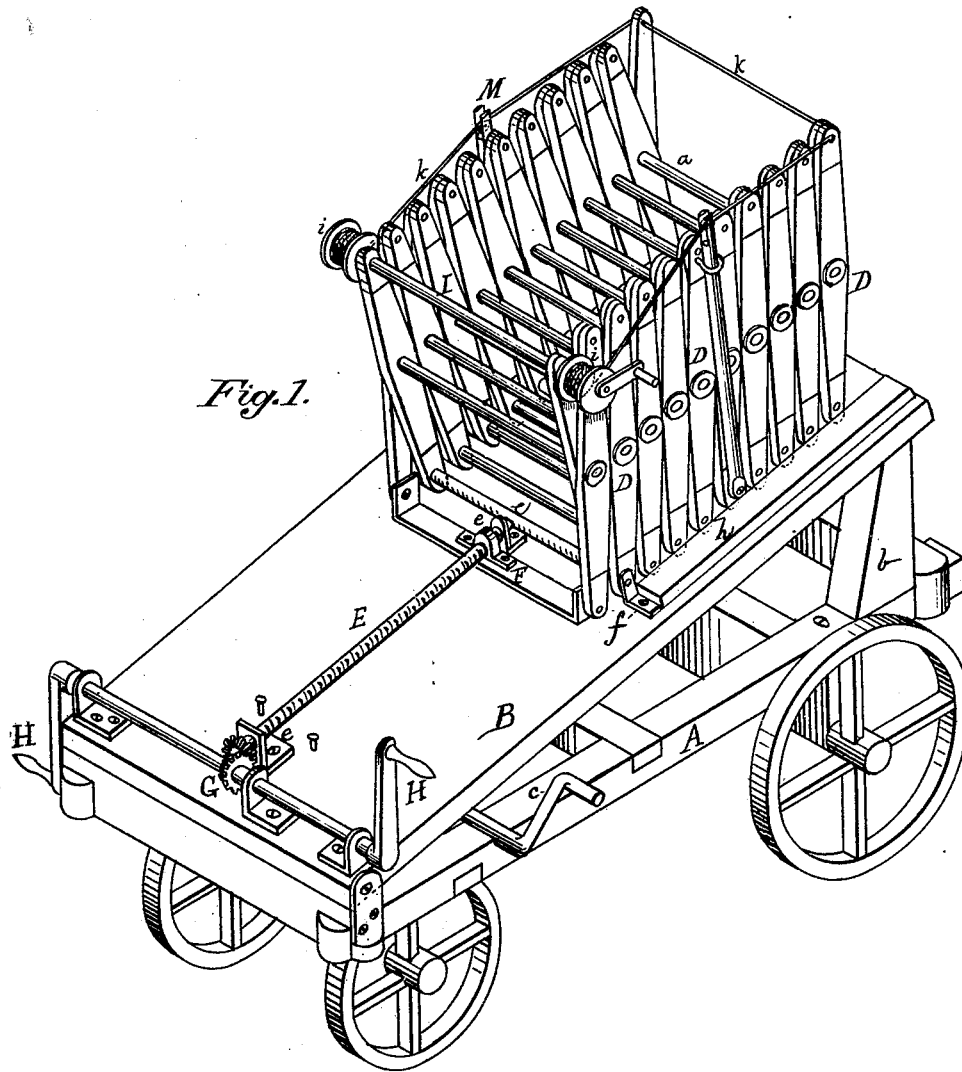

Fig. 1.

Attest:
H. Schott
Mason, Notary

Inventor:

J. W. Tutewiler
 By *A. R. Brown* Atty.

J. W. TUTEWILER.
Fire-Escape.

No. 196,607

Patented Oct. 30, 1877.

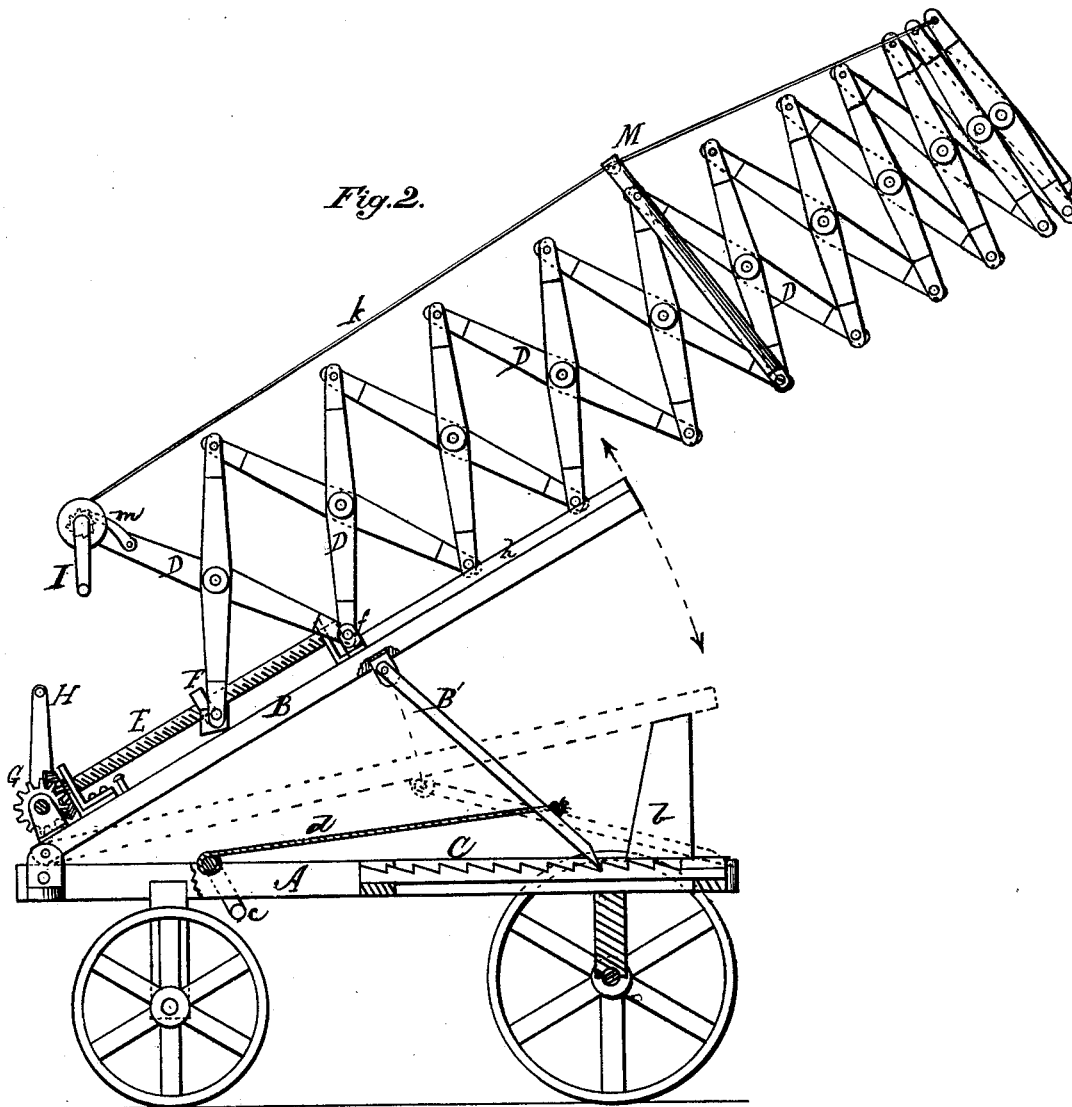

Attest:
H. M. Schott
J. Madsen

Inventor:
J. W. Tutewiler
By *A. R. Brown* Atty.

UNITED STATES PATENT OFFICE.

JOHN W. TUTEWILER, OF INDIANAPOLIS, INDIANA.

IMPROVEMENT IN FIRE-ESCAPES.

Specification forming part of Letters Patent No. 196,607, dated October 30, 1877; application filed July 27, 1877.

To all whom it may concern:

Be it known that I, JOHN W. TUTEWILER, of Indianapolis, in the county of Marion and State of Indiana, have invented certain new and useful Improvements in Fire-Escapes; and I do hereby declare that the following is a full, clear, and exact description thereof, reference being had to the accompanying drawings, and to the letters of reference marked thereon, which form a part of this specification.

My invention relates to the construction of movable fire-escapes, its object being to provide a machine that can be easily transported to any desired point for the purpose of saving life and property from fire; and it consists in the employment of double lazy-tongs, with appropriate devices for operating the same, when constructed and arranged as hereinafter more fully described and claimed.

Figure 1 is a view of my improved fire-escape with the ladder folded or closed, so that it can be readily moved from place to place; and Fig. 2 is a side elevation of the same with the ladder or lazy-tongs partly extended.

A represents the truck or carriage upon which the working parts of the fire-escape are mounted. B is an adjustable inclined plane or platform, hinged in a suitable manner to the forward cross-beam of the truck, and resting, when lowered, upon the posts or standards *b b* at the rear end of the truck. An adjustable support, B', is attached to the lower surface of the platform, and is arranged so that its free end will rest in the teeth of the rack C, being operated by means of the cranked rod *c* and rope or chain *d*, for supporting the platform at any desired angle.

The fire-escape ladder rests on the platform B, to which it is securely attached, and consists of a double lazy-tongs, composed of the bars D D, which cross each other, and are pivoted together, forming a truss-work capable of being folded or extended, as may be desired. These various bars, on each side, are also pivoted to the corresponding bars on the opposite side by means of rods *a a*, which pass horizontally across from side to side, and form the rounds of the ladder when it is extended.

The bars D D may be made of any light and durable material, and when folded are arranged in a nearly vertical position within the guides *h h* on the platform B, as shown in Fig. 1. They are secured to the platform by means of the clamps *f f*, to which are pivoted the lower ends of the second and third bars on each side.

A traveling cross-brace, F, connects the lower ends of the first bars, and is provided with a nut, through which passes the screw E. This screw rests in bearings *e e* at each end, and is connected with suitable cogged gearing G and attached cranks H H, by means of which the screw is operated, and the ladder rapidly extended or folded, as desired.

A cranked shaft, I, extends from the upper end of the second bar D on one side to the corresponding point on the opposite bar, and is provided with spools *i i*, around which is wound a rope, *k*, which passes over pulleys on the standards M, and extends to the extreme end of the lazy-tongs on each side. While the tongs are being extended this rope pays out, and the fire-escape having been elevated to the desired height, the rope is held taut by the pawl and ratchet *m*, thus steadying the ladder and preventing it from sagging.

By turning the cranks H H in the opposite direction the ladder is folded, and the rope *k* may be again wound on the spools *i i* by means of the cranked shaft I, on which they are placed.

The fire-escape ladder constructed as above described may be readily transported, and can be rapidly extended at any angle to the required height, thereby proving an efficient instrument for reaching the upper stories of burning buildings.

Having thus described my invention, what I claim as new, and desire to secure by Letters Patent, is—

1. The combination of the truck A with the inclined platform B, adjustable support B', rack C, rope *d*, and cranked rod *c*, substantially as specified.

2. The adjustable inclined platform B, with its operating devices, consisting of the support B', rack C, rope *d*, and cranked rod *c*, in

combination with the fire-escape ladder or lazy-tongs *D D*, screw *E*, cogged gearing *G*, and cranks *H H*, all arranged and operating substantially as shown and described.

3. The double lazy-tongs *D D*, constructed as shown and described, having the standards *M M*, cranked shaft *I*, and spools *i i* arranged thereon, in combination with the rope *k* and pawl and ratchet *m*, substantially as specified.

In testimony whereof I have hereunto affixed my signature this 19th day of July, 1877, in presence of two witnesses.

JOHN W. TUTEWILER.

Witnesses:

FERDINAND SCHMIDT;
CHARLES P. WEBSTER.