

J. Du BOIS.
Cutter for Lathes.

No. 196,644.

Patented Oct. 30, 1877.

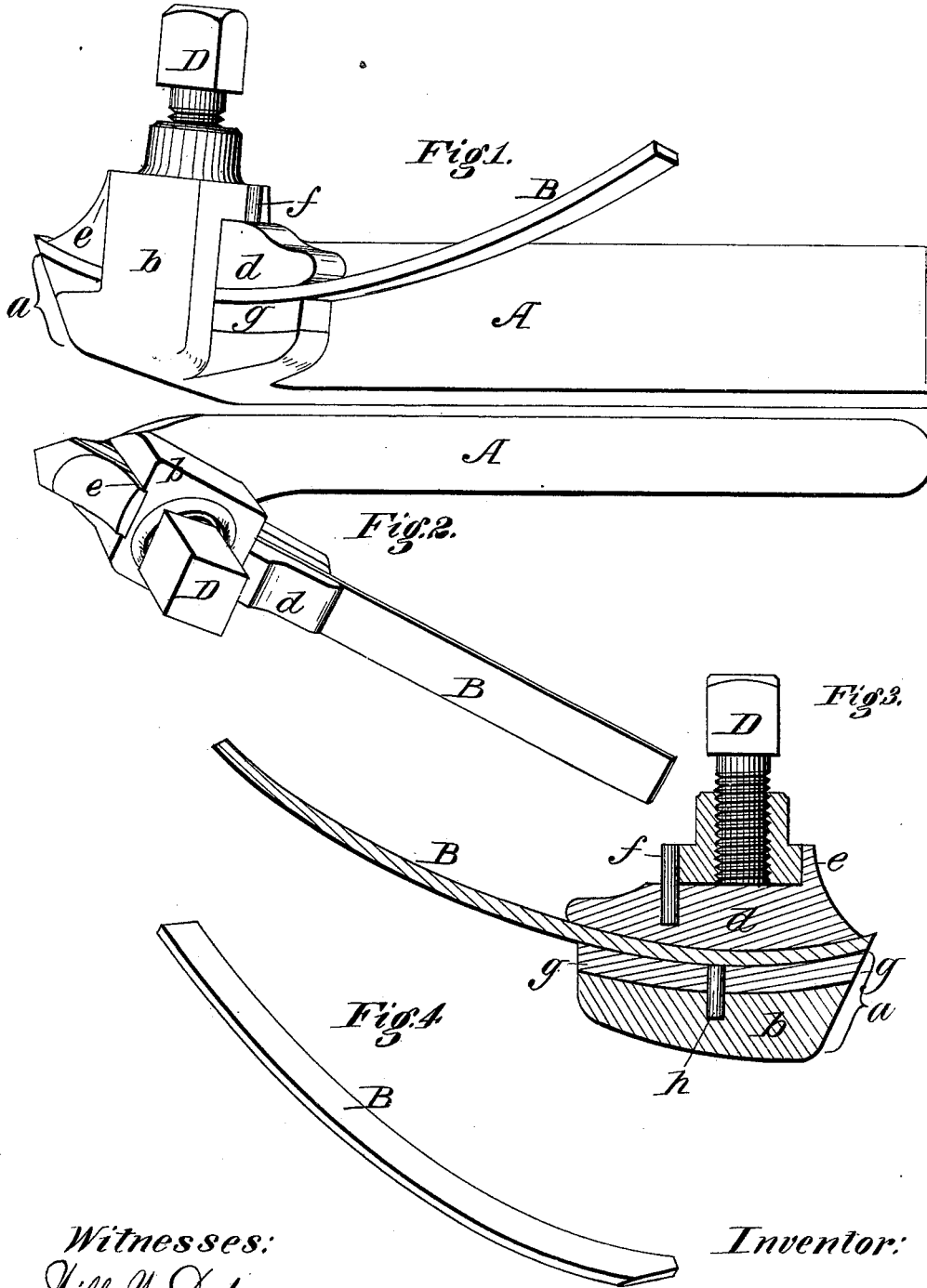

Witnesses:
Hill W. Dodge,
Donn P. Twitchell.

Inventor:
John Du Bois,
By Dodge & Co.
Attys.

UNITED STATES PATENT OFFICE.

JOHN DU BOIS, OF WILLIAMSPORT, PENNSYLVANIA.

IMPROVEMENT IN CUTTERS FOR LATHES.

Specification forming part of Letters Patent No. **196,644**, dated October 30, 1877; application filed September 1, 1877.

To all whom it may concern:

Be it known that I, JOHN DU BOIS, of Williamsport, in the county of Lycoming and State of Pennsylvania, have invented certain Improvements in Tools for Metal-Working Lathes and Planers, of which the following is a specification:

The object of my invention is to produce a tool for metal-turning which will require the use and consumption of a very small amount of steel in comparison with those now in use, and which will at the same time be adapted for work of the heaviest character, which will retain an edge of unchanging form and height, which will need no forging as the cutting-edge wears away, and which will in every respect be the equal of tools hitherto used.

To this end my invention consists in constructing the body of the tool with an end of substantially the usual form, and providing the same on top with a very thin movable steel plate or facing, to receive the wear and form the cutting-edge, the steel being merely a facing or armament on the tool proper, incapable of sustaining itself, and requiring to be supported to its extreme edge by the tool proper.

The invention also consists, further, in a special construction of the body of the tool and the attendant devices for holding the steel facing.

The lathe-tools hitherto devised for metal-turning have been of two general classes, both open to serious objections, which are overcome by my plan of construction.

The tools most generally used consist merely of heavy bars of steel, having their ends forged into the shape required, the end being ground down as the edge wears away, and gradually changes in shape until, as soon happens, it becomes unfit for use, when it is again forged up into shape, and so on repeatedly until the tool becomes too short for use in the tool-post, when the remaining steel, several inches in length, is thrown into the waste heap. Tools of this character require a large amount of steel, and are expensive to make. The frequent re-forging of the end is a matter of considerable trouble and expense, requiring the services of one specially skilled in the art, and the re-

peated heatings greatly injure the quality and efficiency of the metal, and the waste of the worn-out tools entails a serious loss of steel.

In order to overcome, in part, the above troubles, the second class of tools were devised, consisting of stocks or holders to fit the tool-posts, provided with removable self-sustaining steel blades or cutters, arranged in some cases in an upright, and in others in a horizontal, position. In practice these tools, while in some respects superior to the others, are found unsatisfactory, the vertical cutters working out of place, and being unable, on account of the shape of the stock, to pass up closely to the work, while the horizontal cutters could not be given the proper pitch and inclination at the forward end, and could not be relied upon in heavy work, on account of their tendency to chatter and break, and in both forms the amount of steel consumed was considerable. In every instance the cutting blade, tool, or bit employed was made of such size and strength in cross-section as to be self-sustaining against the strain which it received in cutting, and consequently necessitated the consumption of a very considerable amount of steel. In my tool, on the contrary, the steel does not require to be, and is not, self-sustaining, and therefore need have but a tithe of the thickness required in the others.

The greatest and most distinguishing feature of my tool, is that the steel is made of an extreme thinness, and is not self-sustaining, but is, instead, sustained by the tool to its extreme cutting-edge, the whole being, in effect, a turning-tool of ordinary character, with a thin movable surface or veneering on its top to receive the wear. By this method of construction I reduce the amount of steel consumed to a minimum, enabling the performance of the same work with less than half the consumption of tool-steel hitherto required, in addition to which I gain, by reason of the extreme thinness, a greater facility and readiness of grinding the cutting-edge, and am enabled to temper the cutter through its entire thickness, and to give it a greater hardness and resistance to wear than could be done when it was required to be strong and self-sustaining.

In the accompanying drawings, Figure 1

represents a side view of my improved tool; Fig. 2, a top-plan view of the same; Fig. 3, a vertical section of the same on the line $x x$, and Fig. 4 a perspective view of the steel blade detached.

A represents the body of the tool, or tool proper, consisting of a solid bar adapted to fit the tool-post, having its forward end or point a fashioned into the form of an ordinary turning-tool, and having, just in rear of the point, an enlargement, b , containing an oblique mortise or opening, through which there is inserted the thin steel blade or cutter B. The forward end of the steel lies upon and is supported to its extreme edge by the point a , the two having their ends made of the same form, ground flush with each other in front, and fitted closely to each other, so that jointly they form a solid-ended tool having the ordinary form, and adapted for operation in the ordinary manner. The steel lying on top receives the wear and performs the cutting, but depends for its stability upon the direct support received at its end and immediately below its cutting-edge, from the point a .

In order to hold the steel rigidly and immovably in place, a steel block, d , is placed in the mortise upon it, and a jam-screw, D, mounted in the enlargement b in such manner as to bear upon the block and force the same down upon the steel blade, the block d having a vertical shoulder or arm, e , and a vertical pin, f , the former resting against the front and the latter against the rear face of the enlargement b , as shown in Fig. 3, for the purpose of retaining and steadying the block d in the enlargement b , while at the same time permitting its vertical adjustment. In practice, I prefer to notch or seat the shoulder or arm e into the face of the enlargement b , as represented in Fig. 2, in order to hold and sustain it firmly against side play.

The surfaces bearing upon the steel above and below should exactly correspond with each other, and the top block d should extend forward very near to the end of the steel, as shown, so that when the screw is set down the parts will all be held rigidly and solidly together, and the steel prevented from springing or chattering.

By the above arrangement, it will be seen, the steel, no matter how thin, is held firmly above and below, and sustained at the extreme cutting-edge in such manner that it may be used to cut the heaviest chips. In practice, I have frequently, with the tool thus constructed, taken off iron shavings of a thickness greater than that of the steel used in cutting them.

The point or nose a may be forged solidly on the body A; but it is preferred to make its upper portion—that portion which bears against the blade—in a separate piece, g , as shown. This piece g is inserted in the mortise directly under the blade, and secured by means of a vertical pin, h , passed down through

it in the manner shown. By making the part g in a separate piece I am enabled to temper and harden it, and also to substitute in its place others having different shapes at the end, and adapted for blades having ends of corresponding shapes. In this way the one stock or body may be adapted for cutters of various shapes for different classes of work; but ordinarily this change will not be made.

It will be observed that the tool stands in an oblique or inclined relation to the body of the tool, in order that it may extend past the tool-post of the lathe, and that it may sit below the top of the body or bar.

It will also be noticed that the steel is curved in the arc of a circle, so that its rear end will stand up out of the way, and so that the forward end may be given the required pitch or inclination. These two features are, however, shown in a recent patent to E. F. Bengler, and are not claimed by me.

In the use of my tool, the only part consumed is the thin and inexpensive steel blade, which, as it becomes dulled, is moved forward and ground down flush with the sustaining-point of the stock or body. Not only is the thin blade cheaper than, and as durable as, the ordinary heavy blades, but, owing to its thinness, it may be ground and sharpened quicker, and with far less labor. In practice, I find that a blade one-eighth of an inch in thickness is of ample strength, when sustained on my plan, to take off iron chips of great thickness, and for light work blades considerably less in thickness may be used.

Disclaiming the broad idea of providing a stock or body of a turning-tool with a movable steel cutter, and also the obliquity of the cutter with reference to the stock, and also the curvature of the cutter,

What I do claim is—

1. A lathe-tool consisting of a stock or body adapted for use in a tool-post, and a thin blade or sheet of steel lying upon and adjustably secured to the stock, and sustained immediately under its cutting-edge thereby, substantially as shown.

2. The lathe-tool consisting of the stock A, adapted for use in a tool post or holder, and provided with the overhanging nose a , and the thin blade of steel B, secured horizontally and adjustably thereon, and sustained to the extreme cutting-edge by the nose, as shown.

3. The combination, in a lathe-tool, of a thin steel blade or sheet and a sustaining-stock adapted for use in a tool post or holder, and provided with a nose or point extended under and sustaining the blade at its extreme forward edge, the two being flush with each other at the front end, as shown.

4. In a lathe-tool, the combination of a thin steel blade, a stock or holder, substantially such as shown, having a point or nose extending under and sustaining the extreme forward end of the blade, and a clamping block, secured firmly on top of the blade, and extending for-

ward nearly to the edge of the same, to prevent it from breaking or chattering.

5. The combination of the stock A, having the oblique mortise, and the nose *a* and screw D, with the thin steel blade B, and the block *d* resting thereon.

6. The combination of the stock A, having

the nose, the mortise, and the screw, with the removable blocks *d* and *g*, and the thin blade B, as shown.

JOHN DU BOIS.

Witnesses :

P. T. DODGE,
W. W. DODGE.