

W. JEFFERS.
Pumps for Fire Service.

No. 196,669.

Patented Oct. 30, 1877.

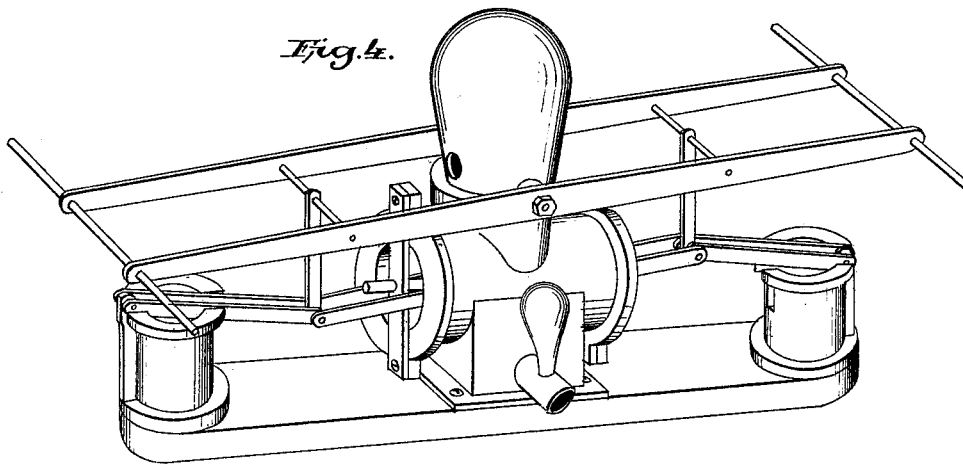
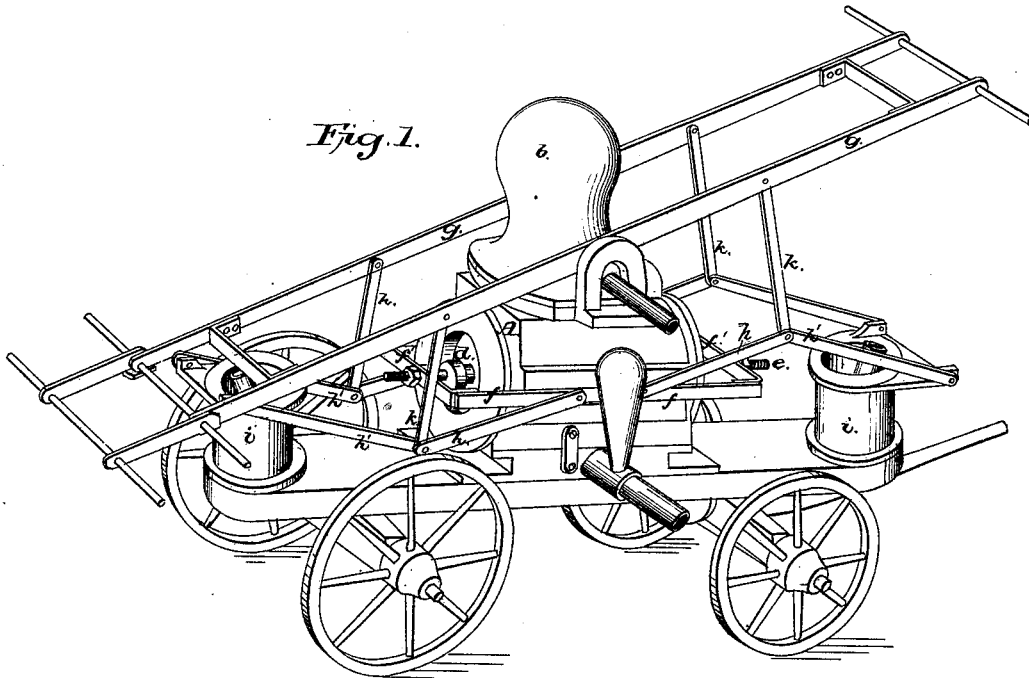

Attest:
Philip T. Lamer
A. B. Cauldwell.

Inventor
William Jeffers
By *Wm. Wood.*
Atty.

W. JEFFERS.
Pumps for Fire Service.

No. 196,669.

Patented Oct. 30, 1877.

Fig. 2.

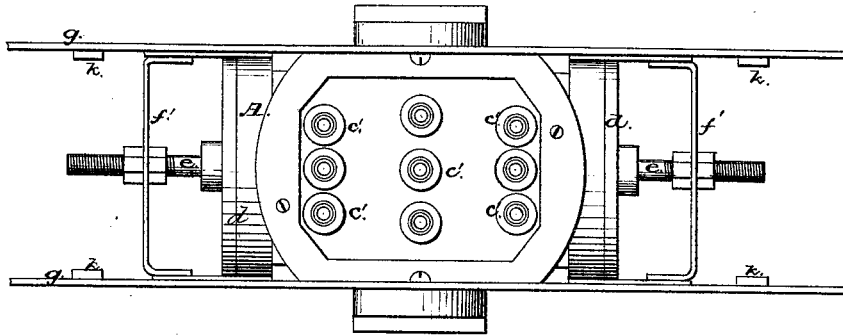
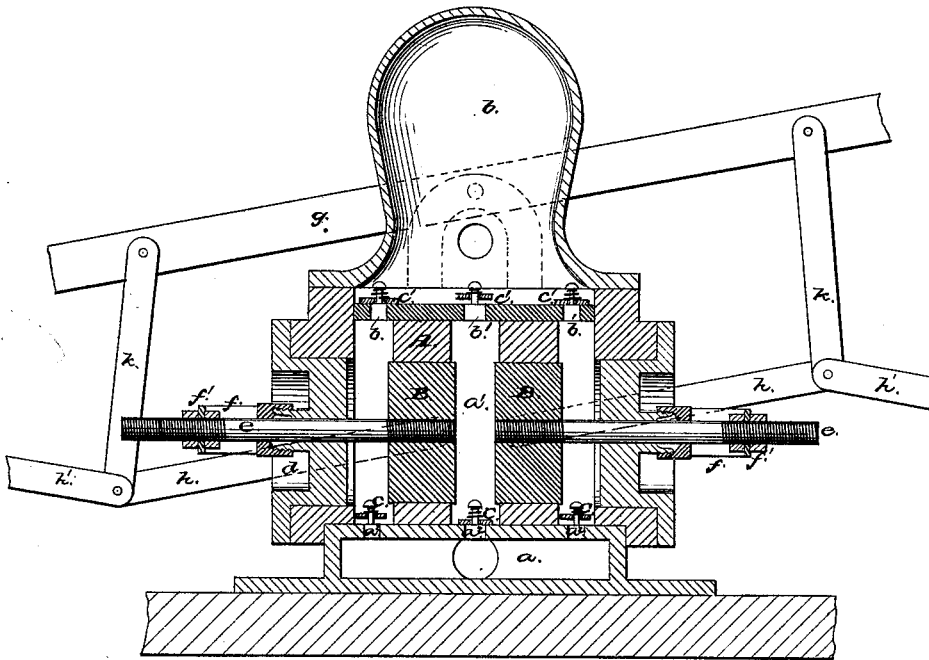

Fig. 3.



Attest:
Philip F. Lamer
att. Caldwell.

Inventor:
William Jeffers
By Wm. Wood.
Atty.

UNITED STATES PATENT OFFICE.

WILLIAM JEFFERS, OF PAWTUCKET, RHODE ISLAND.

IMPROVEMENT IN PUMPS FOR FIRE SERVICE.

Specification forming part of Letters Patent No. **196,669**, dated October 30, 1877; application filed September 19, 1877.

To all whom it may concern:

Be it known that I, WILLIAM JEFFERS, of Pawtucket, in the county of Providence and State of Rhode Island, have invented certain new and useful Improvements in Pumps for Fire Service; and I do hereby declare that the following specification, taken in connection with the drawings furnished and forming a part of the same, is a true, clear, and complete description of my invention.

With an extensive and successful experience in building hand fire-engines, I am convinced that a short quick stroke of the pump-piston is preferable to a slower long stroke, as heretofore, and my present improvements are founded on that belief, strengthened by experimental and actual tests.

The main object of my invention is to attain two complete strokes of the piston to each tilting movement or stroke of the hand-brake, instead of relying, as heretofore, upon a stroke of piston which corresponds with the stroke of the brake.

My invention consists in the combination, with a pump having two pistons, of a tilting hand-brake and jointed levers, which are connected with the brake and pistons, and which hold the pistons at the inner end of their stroke when the hand-brake occupies a horizontal position.

Jointed levers have heretofore been employed in connection with pump-pistons and tilting hand-brakes in fire-engines; but so far as my knowledge extends the jointed levers referred to were of such a character that when the hand-brake was in a horizontal position the pistons were maintained midway of their stroke, and for that reason each piston could make but one stroke to each tilting movement or stroke of the brake.

The pistons in hand-brake pumps, as heretofore constructed, can move no faster than the brake can be moved by hand, and, so far as my knowledge extends, the ordinary valves of such pumps do not fail to close properly of their own weight by reason of the comparatively slow speed attainable with the hand-brake; but in my pump the movement of the piston is so rapid that spring-valves are of special value; and in this connection my invention further consists in the combination of

a pump-cylinder and its pistons, of spring-valves, and a brake which imparts to the piston a double stroke at each single movement of the brake.

I am aware that spring-valves have long been used by myself and others in steam fire-engines; but I am not aware that they were ever before employed in hand-brake pumps, and I know of no brake mechanism heretofore devised with which such valves might be profitably used.

To more particularly describe my invention I will refer to the accompanying drawings, in which Figure 1, Sheet 1, represents, in perspective, a pump embodying my invention, mounted on wheels for use as a hand fire-engine. Fig. 2, Sheet 2, represents, in top view, the pump with the air-chamber removed for exhibiting the eduction-valves. A similar view of the under side of the pump would exhibit the induction-valves, which communicate with a suction-chamber. Fig. 3, Sheet 2, represents the pump in longitudinal central section. Fig. 4, Sheet 1, represents, in perspective, a single-acting pump embodying certain features of my invention, and which is in a form well adapted for stationary service in mills or on ships and steamers.

So far as relates to the double pistons, the pump herein shown is similar to others heretofore known.

A denotes the pump-cylinder, which is mounted on a suitable bed, and is provided with two pistons, B, a suction-chamber at *a*, a vacuum-chamber at *a'*, and an air-chamber at *b*. In the form of pump shown in Figs. 1 to 3, inclusive, there are three separate induction-ports to the cylinder, as at *a²*, all of which communicate by way of spring-valves *c* with the suction-chamber. Two of the induction-ports are located adjacent to the pump-heads *d*, and the third is located centrally. There are also three eduction-ports, as at *b'*, which are located opposite the induction-ports, and communicate through spring-valves *c'* with the air-chamber, the base of which is provided with the usual means for attaching hose.

The piston-rods *e* are provided with stuffing-boxes, and although these operate necessarily as guides for the rods, I provide additional guides for each rod, one at each side of the

pump, as at *f*, and these are connected by a yoke, *f'*, with the piston-rod, which is threaded and provided with nuts, for the purpose of adjusting the yoke on the rod with reference to the piston.

It is advisable, as in all pumps, that the length of the stroke of the pistons be so proportioned to the length of the cylinder as to secure the greatest possible clearance, and to the same end the space between each set of valves and the interior surface of the cylinder should be reduced as far as possible without interfering with the free action of the valves.

It will be seen that no labor is involved in the construction of this pump other than that of the most ordinary character, from the making of the patterns to the finishing, and therefore it can be produced at low cost. The plates on which the valves are mounted are separately constructed, and are held in place by the parts of the pump between which the plates are located.

I prefer to employ two parallel brake-bars, *g*, although a single one may be used. The tilting brake is pivoted on standards, one at each side of the pump-cylinder, and at each end of the brake there is a hand-bar, as usual.

For enabling two lines of men to work at each end of the brake, I employ extra detachable hand-bars, provided with side pieces, which serve as extensions of the brake, and these may be used merely for extending its leverage, if desired. The brake-beam is connected to the piston-rod guides by means of jointed levers *h* and *h'*. The levers *h* are pivoted to the piston-guides *f*, and levers *h'* are pivoted to standards *i*, which are mounted on the bed. The jointed levers are connected with the brake-beam by rods *k*. Adjustable buffers are provided, as heretofore, at each standard *i*, for relieving the shock due to the downward stroke of each end of the brake. It is essential that the standards *i* be of considerable strength and firmly attached to the bed. In order to provide for tool-boxes I prefer to cast the standards in a cylindrical form, with a bolt-flange at the bottom and a strengthening-flange at the top.

The single-acting pump shown in Fig. 4 has two pistons, as in the pump already described; but the cylinder has no heads, and therefore the water-way of the pump is confined to the space between the two pistons, and but one set each of induction and eduction valves is required. Instead of exterior guides, each piston of this pump has a central rod, which has a slide bearing in a diametrical cross-bar, and the jointed levers are connected to the rear side of the piston, are placed nearer each other than before shown, and have one rod for connection with the brake instead of two,

In operation, it is obvious that in this pump, as in the pump before described, and in others of the same class, the water-space between the

two pistons will be filled and discharged at every full movement of the brake; and that in the pump having heads to its cylinder, the water-spaces between the pistons and the heads will also be filled and discharged in the same time. The length of stroke attainable with these pumps is, of course, less than in engines as heretofore built by me; but with the increased number of strokes of the piston, and a practicable increase of the diameter of the pump, I attain readily a capacity in my new pump which is equal to or greater than that of the pumps heretofore used by me in my largest hand-engines.

It will be seen that the jointed levers are so proportioned and arranged, with reference to the pistons and hand-brake, that when the pistons are at the inner end of their stroke the tilting hand-brake is in a horizontal position, and, therefore, if the hand-brake be tilted to the extent of its half-stroke, each piston will be thereby moved a full stroke, and will next make a full return-stroke if the brake be returned to the horizontal position; and that if the hand-brake be moved a full stroke, each piston will make two complete strokes.

There is a slight apparent lost motion with the pump-brake at a portion of the stroke of the brake, commencing just prior to and terminating just after the jointed levers become parallel with the brake; but this I deem a positive advantage, because at that time the pistons are at rest, and the freedom of the brake due to the absence of work, occurs at a time when, from its position, but little force can be exerted thereon, and following this free movement it is all the easier to start the piston from its rest. When either end of the brake is fully elevated, the men on that side can readily exercise their full powers in starting the pistons from their rest, as is usual in hand-engines.

Having thus described my invention, I claim as new and desire to secure by Letters Patent—

1. The combination, with a pump having two pistons, of a tilting hand-brake and jointed levers, which are connected with the brake and pistons, and which hold the pistons at the inner end of their stroke when the hand-brake is in a horizontal position, substantially as described, whereby each piston has imparted to it two complete strokes to each tilting movement or full stroke of the hand-brake, as set forth.

2. The combination with the pump-cylinder, reciprocating pistons, and spring-valves, of a brake which imparts to the piston or pistons a double stroke at each single movement or stroke of the brake, substantially as described.

WM. JEFFERS.

Witnesses:

GEO. W. GARDNER,
CHAS. A. NARLAND.