

J. B. MATEER.
Car-Coupling.

No. 196,687.

Patented Oct. 30, 1877.

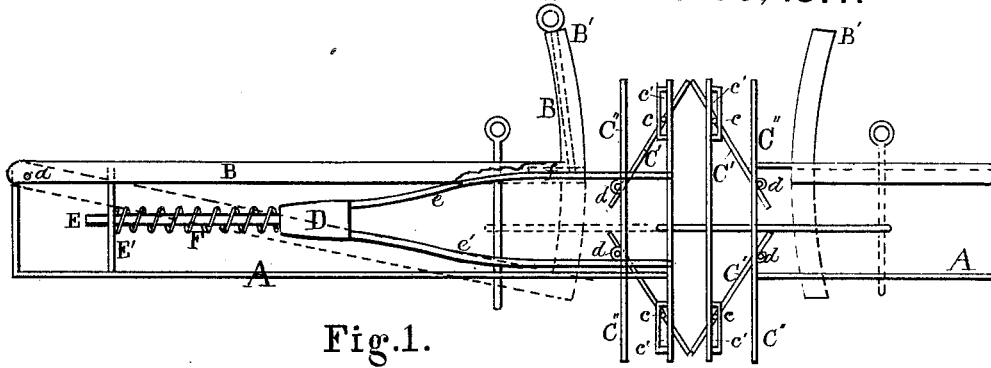

Fig. 1.

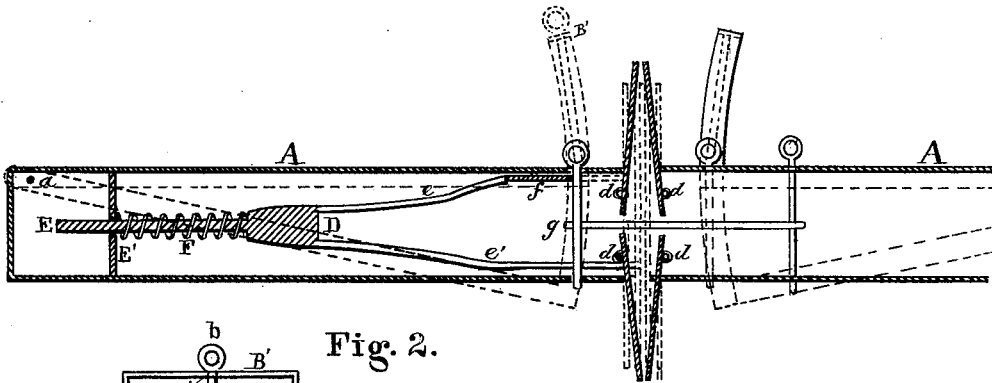

Fig. 2.

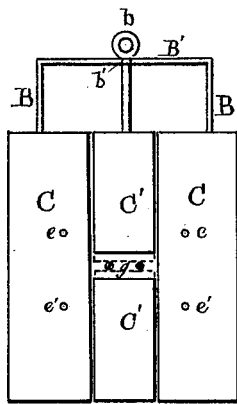

Fig. 3.

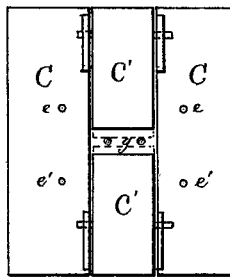

Fig. 4.

Witnesses

C. M. Connell
Stephen F. Hill

Inventor

John B. Mateer
Per *W. A. Singleton*
att'y

UNITED STATES PATENT OFFICE.

JOHN B. MATEER, OF SHIPPENSBURG, PENNSYLVANIA.

IMPROVEMENT IN CAR-COUPINGS.

Specification forming part of Letters Patent No. **196,687**, dated October 30, 1877; application filed October 16, 1877.

To all whom it may concern:

Be it known that I, JOHN B. MATEER, of Shippensburg, in the county of Cumberland and State of Pennsylvania, have invented certain new and useful Improvements in Car-Couplings; and I do hereby declare that the following is a full, clear, and exact description thereof, which will enable others skilled in the art to which it appertains to make and use the same, reference being had to the accompanying drawings, and to letters of reference marked thereon, which form a part of this specification.

This invention relates to automatic railroad-car couplings; and consists in the arrangement of the guiding-plates, which are pivoted upon the face-plates or buffers, so that when the cars come together for coupling, the buffers being forced inwardly, the guide-plates are adjusted automatically; also, in the construction of the brace-rods which are connected to the face-plates or buffers, whereby they are controlled by a single coiled spring, all of which will be more fully explained in the general description, and set forth in the claims.

Figure 1 is a side view of the car-coupling. Fig. 2 is a longitudinal section of Fig. 1. Figs. 3 and 4 are front and inside views of the face-plates or buffers.

A represents the usual box or frame in which the coupling devices are arranged and secured. B is a skeleton frame, L-shaped, having a gallows-bar at B', Fig. 3, with a hole, b', therein, for the bolt b. This frame B is pivoted on each side of A at a, so that its own weight, with that of the bolt b, will cause the latter to fall whenever the bolt is released, as will be explained further on. C C are sectional face-plates, having a space between them for the reception of the guide-plates C' C', which are adjustably secured to plates C'' C'' by means of fixed pivots d d at one end, and to plates C C by sliding pivots e e at the other end, moving in slots e' e', fastened on the backs and near the edges of plates C C, as shown in Fig. 1. C'' C'' are fixed plates, forming part of the frame A, and correspond with the plates C C, and sustain the frame, and by them it is to be secured upon the frame of the car.

The plates C C are attached to rods e e e' e', two above and two below, which pass freely through holes in plates C'' C''. These four rods are fastened to a single stem, D, which is prolonged into a guide-rod, E, around which is a coiled spring, F, which bears upon a guide-bar, E', and a shoulder on D.

On the two upper rods e e is fastened a plate, f, which serves as a platform to sustain the bolt b, when the car is uncoupled, as seen in Fig. 1. In Fig. 2 this plate f is seen in the rear of bolt b, which is in place for holding the link. Consequently, so long as bolt b is in place, the spring F is compressed; so soon as bolt b is lifted above plate f, the spring F, by its recoil, will force the rods e e' and plate C to the position shown in Fig. 1, and the bolt b will rest on plate f, ready to drop into position again, as before described.

When cars are to be connected, they are brought together as represented in Fig. 1. The guide-plates touch each other at top and bottom, the connecting-link passing between them. So soon as these guide-plates have been forced together, until the face-plates C C touch each other and move inwardly, and carry backward the plate f, until the bolt b is released, then it will drop into the link, and thus complete the coupling of the cars.

I claim—

1. The combination of the face-plates C C, the upper and lower rods e e', connected to a single guide-rod, E, substantially as and for the purpose described.
2. The guide-plates C', in combination with the face-plate C, as and for the purpose described.
3. The combination of the brace-rods e e, supporting-plate f, bolt b, and spring F, substantially as and for the purpose described.

In testimony that I claim the foregoing as my own I affix my signature in presence of two witnesses.

JOHN B. MATEER.

Witnesses:

T. H. N. MCPHERSON,
WM. R. SINGLETON.