

L. P. SUMMERS. 3 Sheets—Sheet 1.  
Butt-Grinding Machine.

No. 196,722.

Patented Oct. 30, 1877.

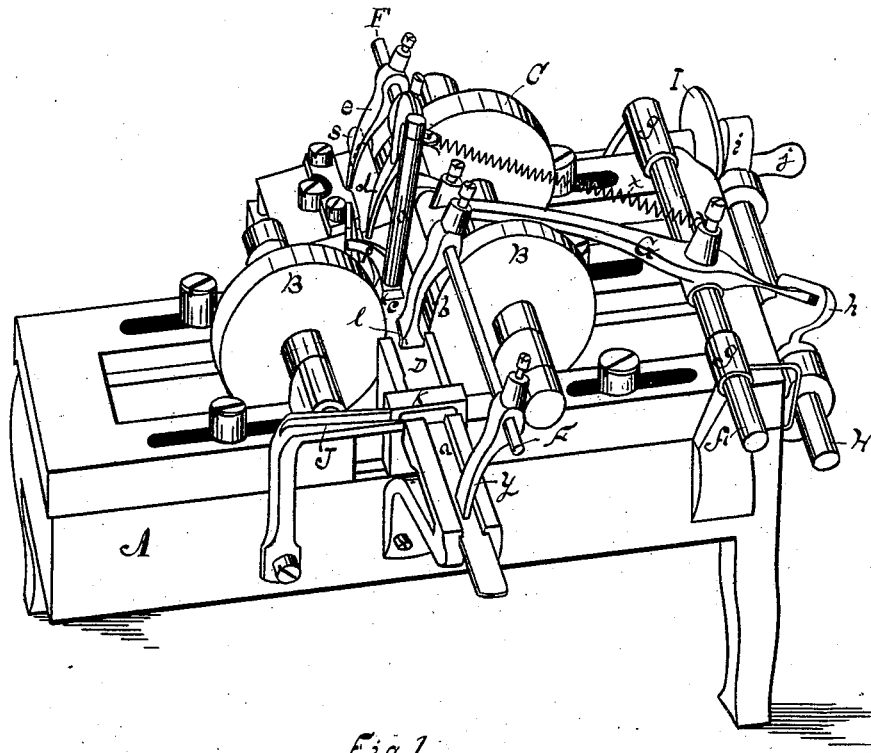

Fig. 1.

Witnesses:  
H. N. Dale.  
W. B. Thomson.

Inventor.  
Lucius P. Summers.  
By James Shepard Atty.

L. P. SUMMERS.  
Butt-Grinding Machine  
No. 196,722. Patented Oct. 30, 1877.

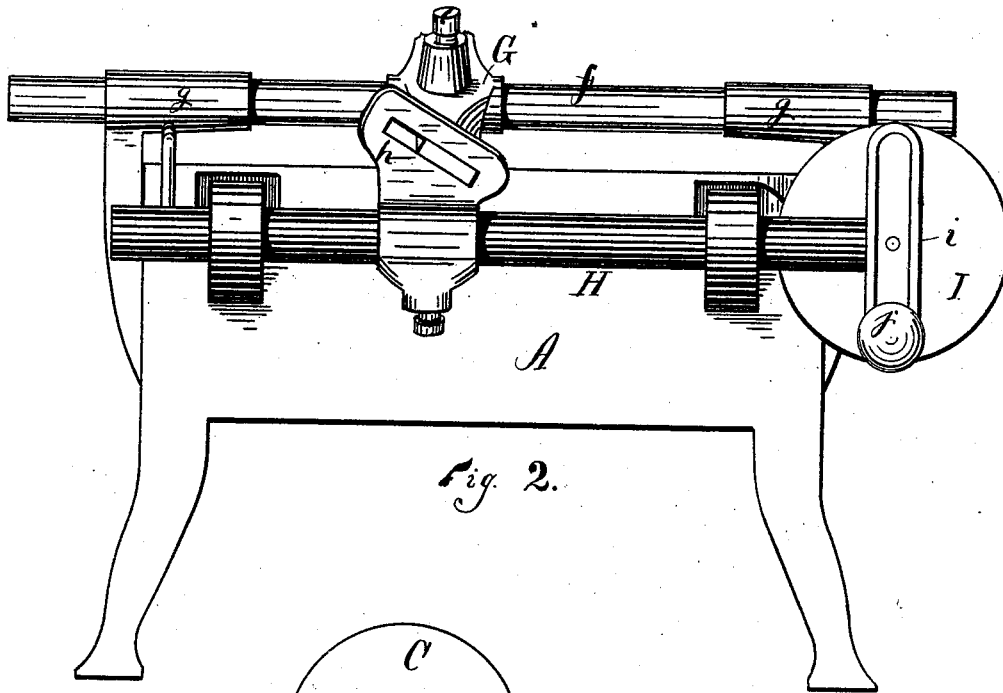

Fig. 2.

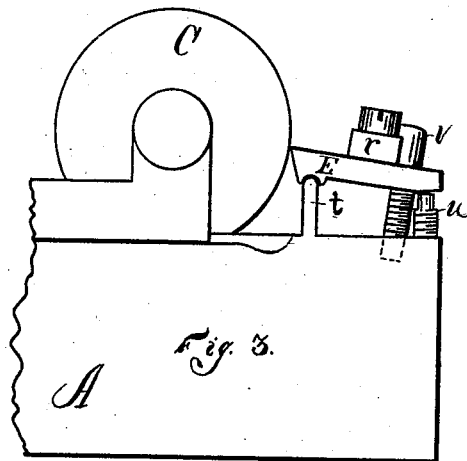

Fig. 3.



Fig. 4.

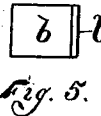

Fig. 5.

Witnesses  
H. N. Gale  
L. S. Burr

Inventor  
Lucius P. Summers  
By James Shepard Atty.

L. P. SUMMERS.  
Butt-Grinding Machine  
No. 196,722. Patented Oct. 30, 1877.

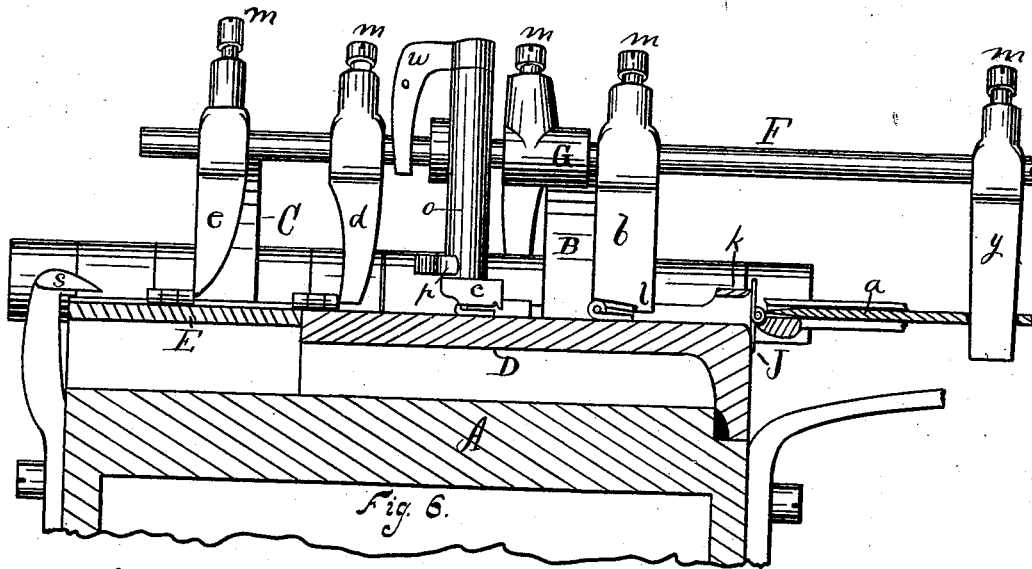

Fig. 6.

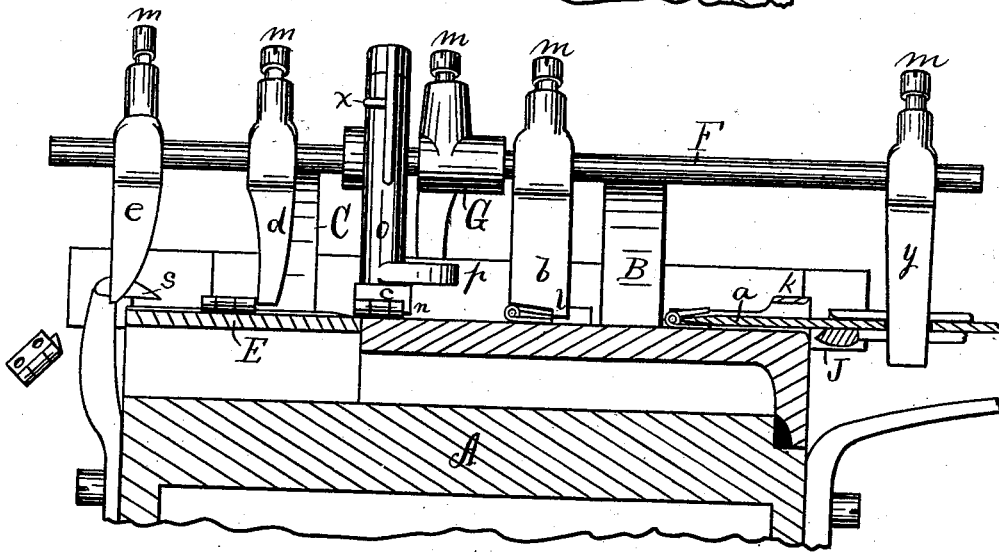

Fig. 7.

Witnesses:  
H. N. Gale.  
W. B. Thomson.

Inventor:  
Lucius P. Summers  
By James Shepards, Atty

# UNITED STATES PATENT OFFICE.

LUCIUS P. SUMMERS, OF NEW BRITAIN, CONNECTICUT, ASSIGNOR TO  
P. & F. CORBIN, OF SAME PLACE.

## IMPROVEMENT IN BUTT-GRINDING MACHINES.

Specification forming part of Letters Patent No. **196,722**, dated October 30, 1877; application filed  
July 18, 1877.

*To all whom it may concern:*

Be it known that I, LUCIUS P. SUMMERS, of New Britain, in the county of Hartford and State of Connecticut, have invented a new and Improved Machine for Grinding Butts, of which the following is a specification:

My machine is designed to receive butts when fully opened, fold them one leaf upon the other, present their end edges to two grinding-wheels for grinding, give them a quarter-turn, present their side edges to another wheel for grinding, present them to a picker which picks open the leaves of the butts, and finally discharge them from the machine, all automatically and very rapidly.

My invention consists in the peculiar construction and operation of certain devices, and in the combination of parts, as hereinafter described.

In the accompanying drawings, Figure 1 is perspective view of a machine for grinding butts, which embodies my invention. Fig. 2 is a partial rear elevation of the same. Fig. 3 is a partial side elevation of the same. Figs. 4 and 5 are face views of two of the conveyers employed in said machine, and Figs. 6 and 7 are transverse sections of said machine on a line just forward of the conveyers.

A designates the frame of the machine, surmounting which are three grinding-wheels, B B C, of any ordinary construction, the same mounted on adjustable carriages secured by bolts passing through slots in a well-known manner, so that the wheels may be moved either forward or backward, as may be desired. The axles of the respective grinding-wheels are provided with pulleys to receive belts for communicating motion to said wheels in the ordinary manner.

Transversely to the frame of the machine, and adjacent to the peripheries of the wheels, there is a bed, which I term the "conveyer-bed," D E, over which is a series of reciprocating conveyers, *a b c d e*, connected with a reciprocating conveyer-bar, F, having both a vertical and longitudinal movement. This conveyer-bar is mounted on the end of a rocking lever, G, rigidly secured to rod *f*, mounted in bearings *g g*, so as to be free to both rock and move longitudinally. The opposite end of the

rocking lever G is twisted, so that its upper and lower sides stand on an incline, (most clearly shown in Fig. 2,) which inclined sides rest in a correspondingly-inclined slot formed in the arm *h* of the reciprocating shaft H, mounted in suitable bearings at the rear of the machine. The end of said shaft H is provided with slotted arm *i*, in which a crank-pin, *j*, on disk I works to impart a reciprocating motion to said shaft whenever the disk I is revolved, which disk may be rotated by any suitable power or machinery. Any other well-known means may be employed to impart a reciprocating movement to the shaft H, and, if desired, it may be so arranged as to make the backward movement more rapid than its forward movement.

When the shaft H moves in one direction, the upper wall of the inclined slot of arm *h* engages the upper side of the rocking lever G, and depresses that end of said lever rocking it on the rod *f*, and raising its opposite end and the conveyer-bar F until the edge of the lever strikes the bottom of the slot in arm *h*. The further movement of the shaft H and slotted arm *h* carries the lever G and conveyer-bar with it, the rod *f* moving endwise in its bearings with the shaft H the whole extent of its further movement in that direction. Upon the return movement of the shaft H, the lower wall of the slot in arm *h* becomes operative, and elevates that end of the lever G, thereby depressing the conveyer-bar and conveyers (except *a*) until the edge of the lever G strikes the upper end of the slot in arm *h*, when the arm carries the lever G and the parts attached thereto to the opposite side of the machine, and with the conveyers in a depressed position. The return of the shaft H, as before described, first elevates the conveyers, and then carries them to one side, and so on repeatedly for every reciprocation of the shaft H, thereby moving the conveyers one way when elevated and the other way when depressed, and changing them from an elevated to a depressed position at one side of the machine, and from a depressed to an elevated position at the opposite side of the machine, the rise and fall of the conveyer-bar taking place prior to any longitudinal reciprocation of said bar.

Transversely to the conveyer-bed D, at its end, is a feed-chute, J, the same being so slotted as to receive one leaf and half of the hub of a butt when open. Over the end of the bed D is a bridge, *k*, which, with the end of the bed, forms an opening of less width vertically than that of an open butt. At one side of the feed-chute opposite the bridge *k* is the support for the first conveyer *a* to work in, said conveyer being a sliding plate with a thin end, and connected with the conveyer-bar F by means of arm *y* passing through a slot or opening in the conveyer *a*, so that it will reciprocate with the conveyer-bar F, but will not rise and fall.

The butts are placed in the feed-chute with their hubs or inside toward the conveyer *a*, as shown in Fig. 6, several butts being placed therein at one time with their ends abutting each other, and pressure applied to the front one to force them to the rear until the rear one is stopped by any suitable stop at the end of the chute, when directly in front of the end of the bed and bridge *k*, as shown in Fig. 6, the same being represented with the conveyer-bar depressed and just ready to move to the left.

At the first movement of the conveyer-bar F the end of the conveyer *a* strikes the hub of the butt in front of the bridge *k*, pushes it through under said bridge, the leaves of the butt being folded over by engaging the end of the bed D and said bridge, carries it onward, and leaves it in the position shown in Fig. 7, which Fig. 7 is represented with the conveyer-bar still depressed, but carried to its extreme position at the left of the machine. The conveyers are then elevated, returned to the right, and again depressed, by the means before described, the conveyer *a* merely withdrawing from the butt, and leaving it on the bed at the point shown in said Fig. 7.

The conveyer *b* is rigidly secured to the bar F, so as to move with it. The lower end of the conveyer constitutes a holding face, at the right-hand side of which is a ledge, *l*. (See Figs. 5, 6, and 7.) The several conveyers are secured to the bar F by means of set-screws *m*, whereby their position on the bar may be properly adjusted, and they should be so adjusted that their pushing faces will be the same distance apart as the distance which the bar F moves longitudinally.

When the bar F rises and moves back to the right, the conveyer *b* passes over the butt last deposited on the bed by the conveyer *a*, and descends, when its holding-face presses upon the side of the butt, and the inner face of the ledge *l* passes down over the right-hand edge of said butt, as shown in Fig. 6, in which position the conveyer *b* firmly holds the butt upon the bed, and when it again moves toward the left it carries the butt with it between the two grinding-wheels B B, and presents both ends of the butt to said wheels, one to each wheel, which grinds or polishes them off, the wheels being set the proper distance apart to correspond with the length of

the butt to be polished, and leaving the butt upon the bed at the point shown under the conveyer *b* in Fig. 7.

The holding-face of the conveyer *c* is shown in Fig. 4, and it has two ledges, *n n*, upon two of its adjoining sides. Instead of being rigidly affixed to the bar F, it is fitted so as to turn freely in an upright socket, *o*, which is secured to said bar, and projecting cornerwise from said conveyer *c* is an arm, *p*. When the bar F is carried to the right, the ledges *n n* are on the front and right of the conveyer *c*, which descends upon the butt with said ledges at the corresponding edges of the butt, and its holding-face holding the butt down upon the conveyer-bed, as shown in Fig. 6. As the conveyer *c* is moved to the left, the arm *p* engages with a stationary post, *q*, Fig. 1, placed in the path of said arm, and causes the conveyer *c* to make a quarter-turn within the socket *o* in passing said post *q*, and thereby give a quarter-turn to the butt, leaving it with its pintle and hub parallel to the length of the bed D E, instead of transversely thereto, as before. At the upper end of conveyer *c* there is an upper arm, *w*, to which one end of a spiral spring, *x*, Fig. 1, is secured, and its opposite end to the screw, which secures the lever G to its rod. When the conveyer C is turned a quarter-turn, as before described, its upper arm *w* pulls on the spring to expand it, so that said spring returns the conveyer back a quarter-turn so soon as its disengagement from the arm *p* will permit. At the next forward movement of the bar F the conveyer *d* engages the right-hand end of the butt, and pushes it on the bed E in front of the wheel C, which grinds the side edges of its two leaves, a suitable gage, *r*, Fig. 1, preventing the butt from working away from said wheel. At the next forward movement of the bar G the conveyer *e* takes the butt and throws it off the end of the bed. In passing it engages the end of the picker *s*, which works between the two leaves of the butt, and forces them partially open, ready for cleaning, plating, &c., thereby avoiding the tedious process of opening them by hand.

In the foregoing description I have only followed one butt on its way through the machine; but, in practice, when once under way, if the machine is kept full, all of the several conveyers are simultaneously at work, as represented in Figs. 6 and 7.

Suitable gages, adjustable or otherwise, may be employed to guide the butts in their proper path along the conveyer-bed. The portion E of this bed is slightly inclined, so as to present the edges of both leaves to the wheel C at the same angle; consequently its rear corner will rise above the level of the bed D, and may be chamfered off a little at the junction of D and E, so that the butts will freely slide over said junction. For the purpose of properly adjusting this bed E, it is mounted at its rear side on a rounded ledge, *t*, Fig. 3, on which it can rock, and at its front on the ends of two

screws, *u u*, which are screwed into the frame A, and it is held in place by a single screw, *v*, by means of which screws *u u* and *v* the bed E can be set on different angles to the wheel C and secured in place. It should be so adjusted that, when the butt to be ground is closed and placed on it, said butt will be equally ground on both sides of a line running from the axis of the wheel to the axis of the hinge-pintle, and if so adjusted both leaves of the butt will be presented to the wheel at the same angle.

I claim as my invention—

1. The bridge *k* and end of bed D, with opening between, in combination with the reciprocating conveyer *a*, substantially as described, and for the purpose specified.

2. The bridge *k*, end of bed D, and reciprocating conveyer *a*, in combination with the feed-chute J, extending between the parts *a* and *k* D, substantially as described, and for the purpose specified.

3. The combination of the bed D, wheels B B, conveyer *b*, provided with holding-face and ledge *l*, and mechanism for reciprocating, raising, and lowering said conveyer, substantially as described, and for the purpose specified.

4. The combination of the reciprocating conveyer *a*, bridge *k*, bed D, wheels B B, conveyer *b*, and mechanism for operating said conveyers, substantially in the manner above described, and for the purpose specified.

5. The rocking-lever G, mounted on rod *f*, the latter adjusted in bearings for freely moving longitudinally as well as rocking, in combination with the reciprocating shaft H and inclined slotted arm *h*, substantially as described, and for the purpose specified.

6. The combination of reciprocating shaft H, the inclined slotted arm *h*, rocking-lever G, adjusted to make the double movement described, the conveyer-bar F, and series of conveyers connected thereto, substantially as described, and for the purpose specified.

7. The conveyer-bar F and its operating mechanism, in combination with socket *o*, conveyer *c*, arm *p*, post *q*, and returning-spring, substantially as described, and for the purpose specified.

8. The combination of the bed E, gage *r*, wheel C, conveyer *d*, and mechanism for reciprocating, raising, and lowering said conveyer, substantially as described, and for the purpose specified.

9. The combination of the bed E, picker *s*, reciprocating-conveyer *e*, and its operating

mechanism, substantially as described, and for the purpose specified.

10. The combination of the beds D E, wheels B B and C, conveyers *b*, *c*, and *d*, conveyer-bar F, and its operating mechanism, substantially as described, and for the purpose specified.

11. The combination of the beds D E, wheels B B and C, picker *s*, conveyers *b*, *c*, *d*, and *e*, conveyer-bar F, and its operating mechanism, substantially as described, and for the purpose specified.

12. The conveyer-bar F, having a reciprocating movement both laterally and vertically, the conveyer *b* moving therewith, in combination with the conveyer *a* and its connecting-arm *y*, substantially as described, and for the purpose specified.

13. The combination of the feed-chute J, bridge *k*, conveyer *a*, beds D E, wheels B B C, conveyer *b*, conveyer and turner *c*, conveyers *d e*, picker *s*, conveyer-bar F, and mechanism for moving said bar both laterally and vertically, substantially as described, and for the purpose specified.

14. The combination of conveyer-bed, grinding wheel or wheels, and a conveyer operated by suitable mechanism to move forward when depressed, to rise at the end of its forward movement, move backward when thus raised, and to fall before moving forward again, substantially as described, and for the purpose specified.

15. In a machine for grinding butts, the conveyer *b*, provided with a holding-face and the ledge at one side of said holding-face, substantially as described, and for the purpose specified.

16. In a machine for grinding butts, the conveyer and turner *c*, hung to turn freely, and provided with a holding-face, and ledges *n n* on two adjoining sides of said face, substantially as described, and for the purposes specified.

17. The combination of conveyer-bed, grinding-wheels B B, placed one on each side of said bed, the grinding-wheel C, placed in line with one of the wheels B, at one side of said bed, and mechanism for automatically conveying the butts along the conveyer-bed, and presenting their respective edges to said wheels for grinding, substantially as described.

LUCIUS P. SUMMERS.

Witnesses:

JAMES SHEPARD,  
F. L. HUNGERFORD.