

G. R. WINKLER.
Oscillating Pumps.

No. 196,732.

Patented Oct. 30, 1877.

Fig. 1.

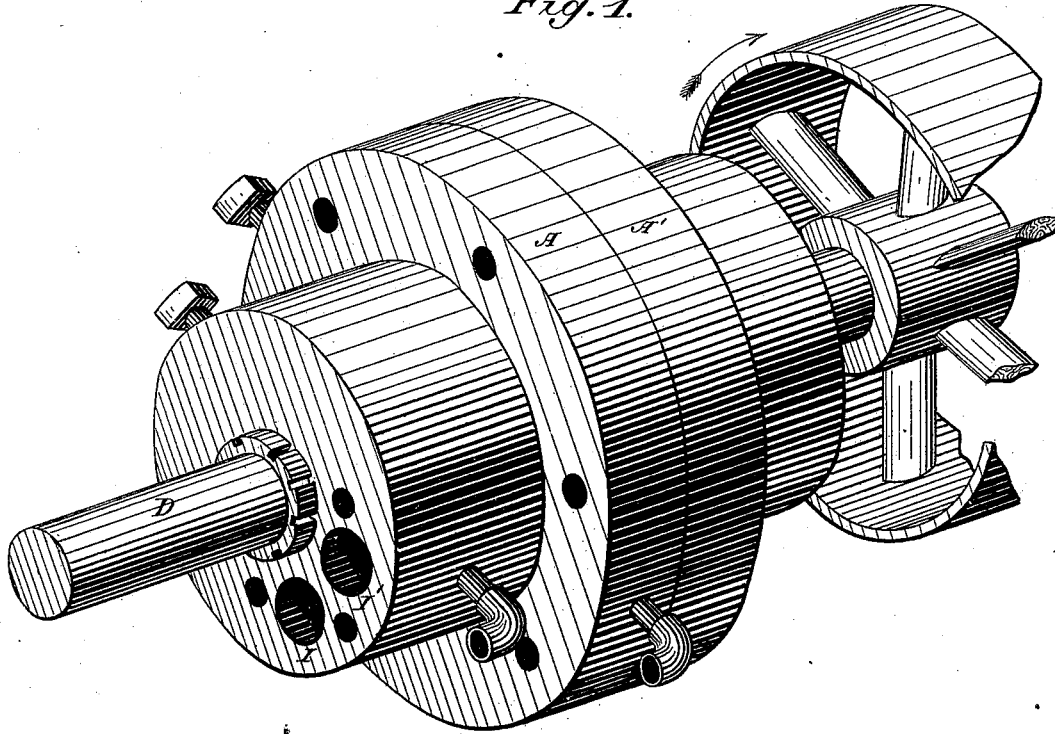

Attest:
R. T. Dyer.
L. M. Seely

Inventor:
Gustavus R. Winkler
by Geo W Dyer,
Att'y

G. R. WINKLER.
Oscillating Pumps.

No. 196,732.

Patented Oct. 30, 1877.

Fig. 2.

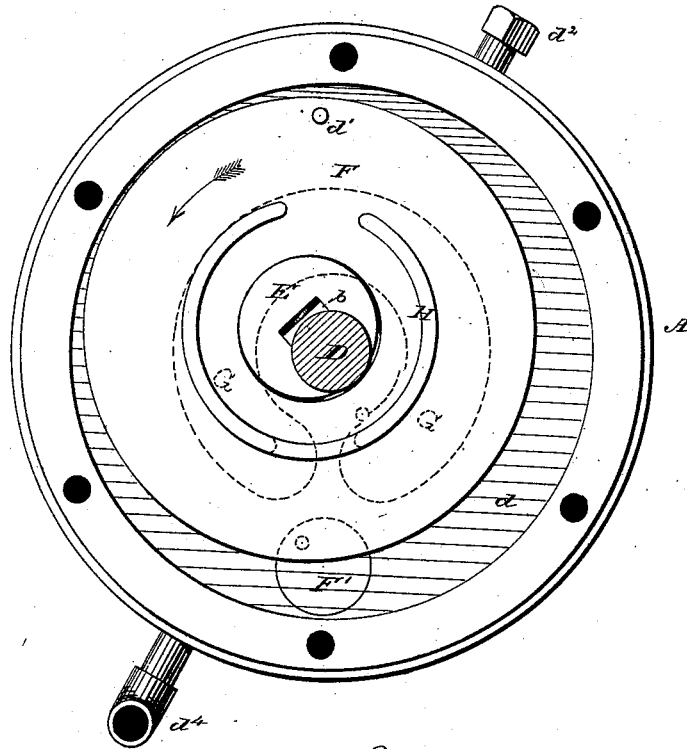
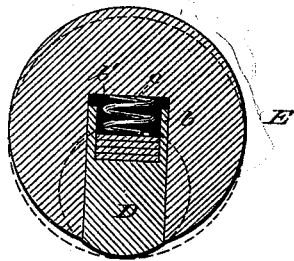

Fig. 3.



Attest:
R. M. Dyer
L. McKelley

Inventor:
Gustavus R. Winkler
by Geo. W. Dyer
att'y

G. R. WINKLER.
Oscillating Pumps.

No. 196,732.

Patented Oct. 30, 1877.

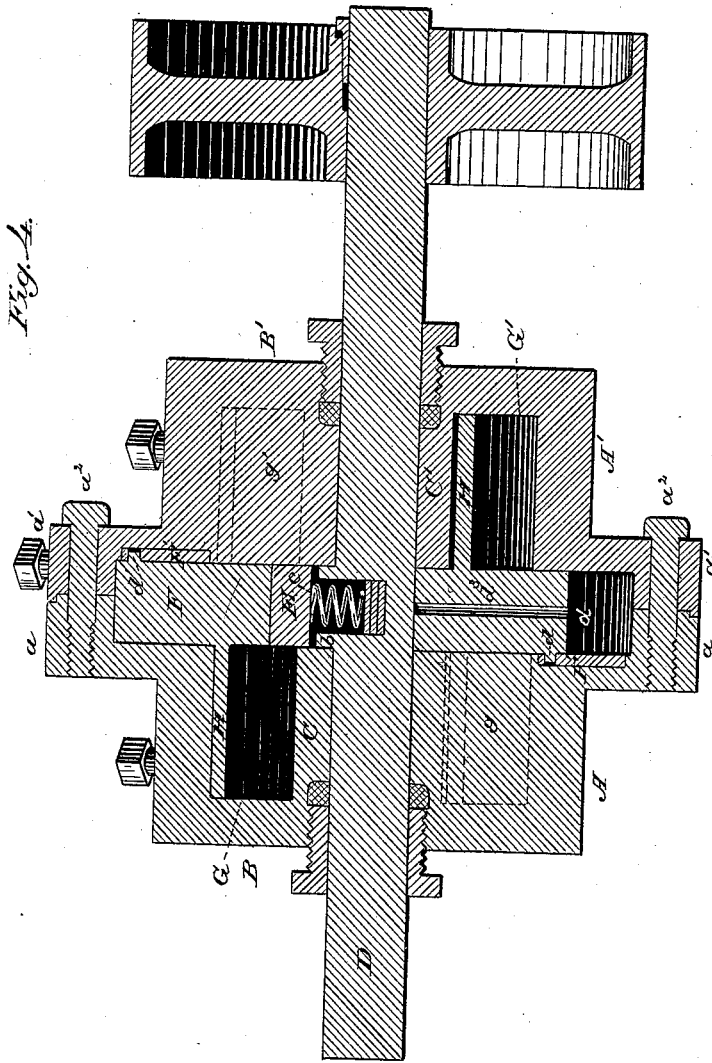

Fig. 4.

Attest:
R. T. Dyer
L. M. Sully

Inventor:
Gustavus B. Winkler
by Geo. W. Dyer
attor.

G. R. WINKLER.
Oscillating Pumps.

No. 196,732.

Patented Oct. 30, 1877.

Fig's. 5.

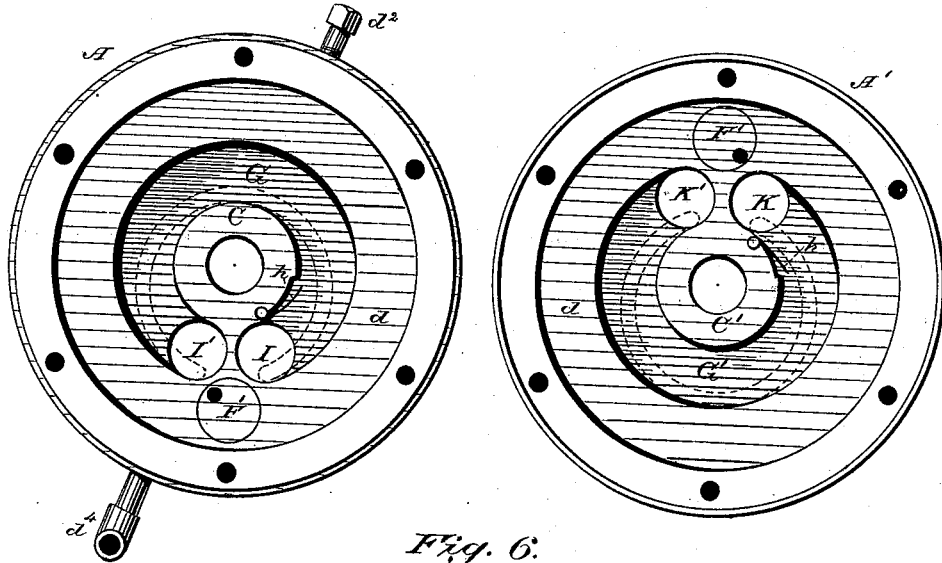
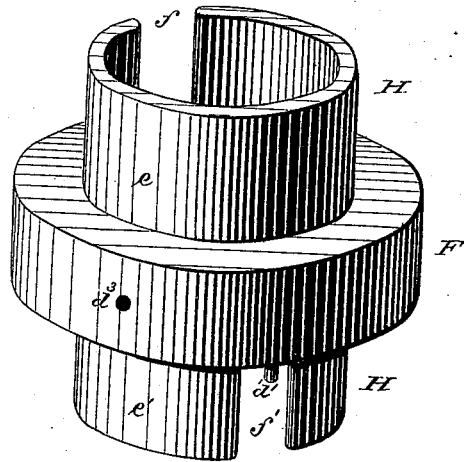

Fig. 6.



Attest:
R. T. Dyer.
L. W. Dyer

Inventor:
Gustavus R. Winkler
by Geo. W. Dyer
Atty.

UNITED STATES PATENT OFFICE.

GUSTAVUS R. WINKLER, OF WILLIAMSPORT, PENNSYLVANIA.

IMPROVEMENT IN OSCILLATING PUMPS.

Specification forming part of Letters Patent No. **196,732**, dated October 30, 1877; application filed August 27, 1877.

To all whom it may concern:

Be it known that I, GUSTAVUS R. WINKLER, of Williamsport, in the county of Lycoming and State of Pennsylvania, have invented a new and useful Improvement in Force-Pumps; and I do hereby declare that the following is a full and exact description of the same, reference being had to the accompanying drawings, and to the letters of reference marked thereon.

The object I have in view is the production of an oscillating pump which will be cheap and compact in construction, durable in wear, and efficient in operation; and my invention therein consists, first, in the peculiar scroll-plunger, and in the means for operating the same; second, in the construction of such plunger with a central disk, which divides the interior of the pump into two parts, each provided with inlet and outlet ports; third, in the peculiar construction of the shell of the pump, cast in two pieces with the heads and the internal cylinders; fourth, in the devices for attaching the eccentric to the operating-shaft so as to have a limited movement thereon; and, further, in the various combinations of the operative parts, as fully hereinafter explained.

In the drawings, Figure 1 represents a perspective view of the pump; Fig. 2, an elevation, with one-half of the shell removed and the shaft in section; Fig. 3, a cross-section through the operating eccentric and shaft; Fig. 4, a vertical section of the pump on the line of the shaft; Fig. 5, elevations, from the inside, of the heads of the pump, showing the plunger in dotted lines; and Fig. 6, a separate view of the plunger.

Like letters denote corresponding parts.

The shell of the pump is of cylindrical form, and is made in two parts, A A', with enlarged inner portions a a', secured together by bolts a². The heads B B' of the cylinder are, preferably, cast in one piece with the corresponding parts of the shell, and on the inside of these heads are cast short cylinders C C', which project centrally inward, leaving a space between their ends, when the parts A A' are secured in position. The casing of the pump is supported on any suitable bed, and a shaft, D, runs centrally through the heads B B' and

cylinders C C', and turns in proper journal-bearings, which shaft is provided with a pulley or cog or other gearing, through which the pump is rotated by steam or other power. On the shaft D, between the ends of the cylinders C C', is keyed an eccentric, E. The shaft at this point is squared, and projects to one side of the body of the same, to form a short crank, as shown by b, and the eccentric has a rectangular slot, b', passing through one of its sides, which slips over the squared portion b. A spring, c, is placed between the end of this crank and the inner end of the slot b', which allows the eccentric a limited movement on the squared shaft. F is a disk, having a central circular hole, in which the eccentric E revolves. This disk fills the entire space between the cylinders C C', and projects into the extended chamber d, formed by the enlarged inner ends of the parts of the shell, the disk having an oscillating movement in such space. This disk, with the cylinders C C', divides the cylinder of the pump into two annular chambers, G G'.

To guide the disk in its movement, I secure to its sides, near the periphery thereof, two or more pins, d', which set into holes in guide wheels or disks F'. The guiding-disks are made of the required size, and are set into the sides of the enlarged portions of the shell within the chamber d. I have shown in the drawing only two of these guiding-disks, one on each side of the disk F, and on diametrically opposite sides of the pump; but I prefer, in practice, to use six of the said guiding-disks, three on each side.

For lubricating the working parts of the pump, the chamber d is partly filled with oil through a plug, d², in the top of the shell, and the disk F, by moving around in this chamber, keeps its frictional-surfaces well oiled. A number of holes, d³, are bored through the disk F, from its periphery to the central opening, in which the eccentric works, and such eccentric is thereby kept lubricated from the oil in the chamber d. Any impurities or any water which may get into the chamber d is worked, by the disk F, into the bottom of such chamber, and can be carried off through a pipe, d⁴.

With the disk F is cast a scroll-plunger, H,

projecting on each side of such disk, and abutting water-tight against the heads B B'. This plunger is composed of two cylindrical wings, *e e'*, having rectangular slots *f f'*, which extend from the outer ends of the wings into the disk F. These slots are placed diametrically opposite each other, the slot *f* in the wing *e* being in the upper side of its wing, while the slot *f'* is in the lower side of the wing *e'*.

In the lower part of the head B are formed two ports, (inlet and outlet,) I I', which are separated from each by a partition, *g*. This partition projects inwardly to the inner end of the cylinder C, and from such cylinder extends to the shell of the pump, dividing the annular chamber G at this point, and projecting into the slot *f* of the plunger. These ports are connected with suitable suction and force pipes. (Not shown.)

The head B' is provided with a similar partition, *g'*, and like inlet and outlet ports K K', situated at the lower periphery thereof, and having water-conveying pipes similar to those connected with the ports I I'.

The two suction-pipes may be united at any proper point, and have a single pipe, through which the water will be drawn; and I also prefer, in constructing my pump, to join the two outlet-pipes, and lead therefrom a single pipe, for delivering the water at the desired place.

A spring-packing, *h*, may be placed on the side of each of the internal cylinders, just inside of the inlet-ports, to prevent back pressure; but this packing can be dispensed with.

The suction-pipe being connected with the water-supply, and the shaft turned in the direction shown by the arrows, the water will be drawn in the ports I K, and forced from the ports I' K', since, by the peculiar oscillating motion of the scroll-plunger, there will be a constant suction at the inlet-ports, alternately within and on the outside of such plunger, and at the same time a constant forcing of the water at the outlet-ports, this pressure being exerted alternately by the contraction of the space within the plunger and that between such plunger and the shell of the pump.

While on one side of the disk F the plunger is throwing but a small stream, the opposite side of the plunger will be exerting its greatest pressure; (shown in dotted lines, Fig. 5;) and both outlet-pipes being joined, as above described, these pressures may be so graduated that a constant stream will be ejected without the use of an air-chamber to equalize the flow.

Should any small obstruction get between the scroll-plunger and the shell, or between such plunger and the inner cylinders, the ec-

centric would move upon the spring *e*, and allow the plunger to pass over the obstruction.

The pump, constructed as above described, is very simple in construction, has no valves which are expensive to replace or keep in repair, and requires but little packing. In its operation there is no back pressure, and consequently no leakage; and the scroll-plunger, having a constant forward motion, there is no waste of power in overcoming the momentum of the plunger, as in ordinary pumps. There is also no friction of the parts, except at the outer ends of the plunger, where it rubs against the heads, and on the side of the disk F at the points in contact with the extended portion of the shell, so that the inside of the pump can be covered with vulcanized india-rubber or other substance to prevent corrosion, thus adapting the pump for use in pumping out mines and other like places.

Having thus fully described my pump, and explained some of its advantages, what I claim as new therein, and desire to secure by Letters Patent, is—

1. In an oscillating pump, the scroll-plunger H, substantially as described.

2. The combination of the scroll-plunger and an eccentric-shaft for operating the same, substantially as and for the purposes set forth.

3. The combination, with the scroll-plunger, of the disk F, for dividing the cylinder of the pump into two parts, substantially as and for the purposes set forth.

4. The combination, with the shell of the pump, of an oscillating plunger and two sets of inlet and outlet ports, arranged substantially as described and shown.

5. The combination of the shell A A', heads B B', and cylinders C C', cast in two pieces, substantially as described and shown.

6. The combination, with the shell, heads, and internal cylinders, of the eccentric disk F, slotted plunger H, inlet and outlet ports, and partitions *g g'*, substantially as described and shown.

7. The squared portion *b* of the shaft, in combination with the slotted cam E and spring *e*, substantially as described and shown.

8. The combination, with the scroll-plunger, of the eccentric for operating the same, and the guiding-disks for controlling its motion, substantially as and for the purpose set forth.

This specification signed and witnessed this 9th day of July, 1877.

GUSTAVUS R. WINKLER.

Witnesses:

H. C. McCORMICK,
CHARLES MILLER.