

T. J. MAGNER & C. L. THOMAS.
Side-Spring Vehicle.

No. 196,757.

Patented Nov. 6, 1877.

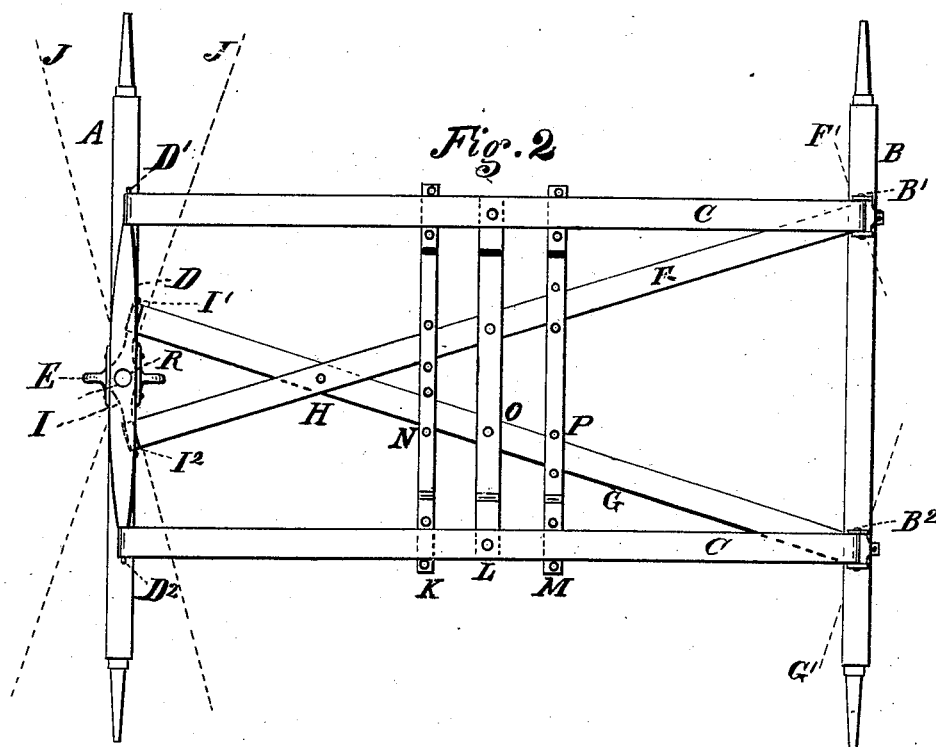
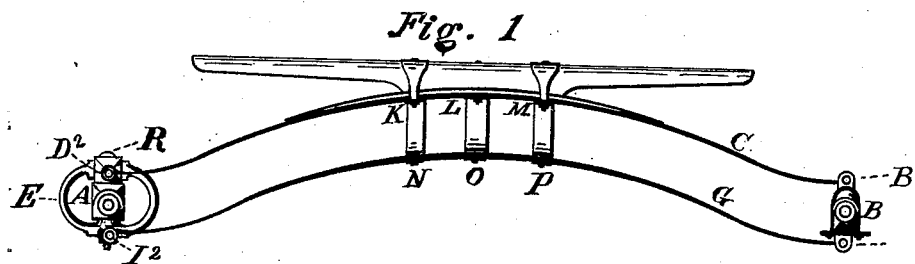

Witnesses,

N. B. Menaar,
O. L. Pond

Inventors,

Thomas J. Magner
Charles L. Thomas,
By James Sangster
Atty.

UNITED STATES PATENT OFFICE.

THOMAS J. MAGNER AND CHARLES L. THOMAS, OF HORNELLSVILLE, N. Y.

IMPROVEMENT IN SIDE-SPRING VEHICLES.

Specification forming part of Letters Patent No. **196,757**, dated November 6, 1877; application filed July 16, 1877.

To all whom it may concern:

Be it known that we, THOMAS J. MAGNER and CHARLES L. THOMAS, both of Hornellsville, in the county of Steuben and State of New York, have jointly invented certain new and useful Improvements in Vehicle-Springs, which improvements are fully set forth in the following specification and accompanying drawings, in which—

Figure 1 represents a side elevation, and Fig. 2 a plan or top view.

The object of our invention is to produce a simple, strong, and durable spring for light wagons, carriages, or other vehicles; and it consists of an upper set of springs pivoted above both axles and arranged parallel with each other, or nearly so, in combination with a lower set of springs pivoted, in the peculiar manner hereinafter described, below both axles, and arranged in the form of an X-shaped brace, both sets of springs being rigidly held together and in place by suitable braces near the center, the back ends of the upper set of springs being pivoted or jointed to the upper sides of the rear axle, and the front ends pivoted to a cross-piece, which is firmly fastened to a double brace or yoke, through which the front axle passes, and is held by a king-bolt; and the back ends of the lower springs being pivoted to the lower part of the rear axle in a vertical line, or nearly so, below the upper springs, at an angle thereto, so as to allow them to cross each other near the front of the vehicle, and connect by joints to a bent cross-piece fastened to said yoke or double brace, the arrangement and form of said brace being such that the draft is equally distributed between the upper and lower springs, or nearly so, as will be more clearly hereinafter shown.

In said drawings, A is the front and B the rear axle. C represents the upper set of springs, arranged on each side, as shown. They are attached to the upper part of the rear axle B by means of the joints or pivots B¹ B², and to the fore part of the vehicle by means of the cross-piece D and joints or pivots D¹ D².

The bolster or cross-piece D is rigidly fastened to the upper part of the double brace or yoke E. F G represent the lower set of springs. They are fastened to the lower part of the rear axle by means of pivots or joints arranged at an angle to the axle, as shown by

the dotted lines F' G', Fig. 2, so that they will cross each other at or about the point H, in advance of the center of the vehicle, where they are fastened by a bolt or its equivalent, thereby forming a strong X-shaped brace, as well as an easy spring, which insures great strength, and prevents any lateral movement.

The front ends of said springs are pivoted to a cross-piece, I, at the ends I¹ I², as shown by dotted lines, Fig. 2. This cross-piece is arranged below the axle at the front of the vehicle, and is firmly fastened to the brace or yoke E, or forms a part thereof, and is provided with pivots bent to the proper angle to receive the springs.

The yoke or double brace E is arranged so that the front axle passes through it, and is fastened in place by the king-bolt R, so as to vibrate either way, as shown by the dotted lines J J, Fig. 2.

The upper and lower sets of springs are securely fastened together by means of bent cross-braces N O P, which are formed so that the outer ends project up and outward, so as to receive and hold the upper springs at K L M, to which they are fastened by rivets or bolts, and so that the other part of said braces shall project down far enough to receive the lower springs, to which they are firmly riveted or otherwise fastened, the crossing of the lower springs at a point in advance of the center so separating them at the center that they afford a wide and steady bearing for the cross-braces, with which they constitute a strong and rigid support.

We claim as our invention—

1. The combination of the side springs C C, pivoted above the rear axle and to the bolster, the lower springs F G, crossing each other in advance of the center, pivoted below the axles, and the cross-braces N O P, connected to the side springs and to the cross-springs at the rear of the crossing-point, as set forth.

2. The yoke E, provided with lateral projecting arms forming a cross-piece, I, to the ends of which the cross-springs F G are secured, as set forth.

THOMAS J. MAGNER.
CHARLES L. THOMAS.

Witnesses:

S. M. CONVERSE,
H. C. SYKES.