

C. B. WITHINGTON.  
Grain-Binder.

No. 196,775.

Patented Nov. 6, 1877.

*Fig 1*

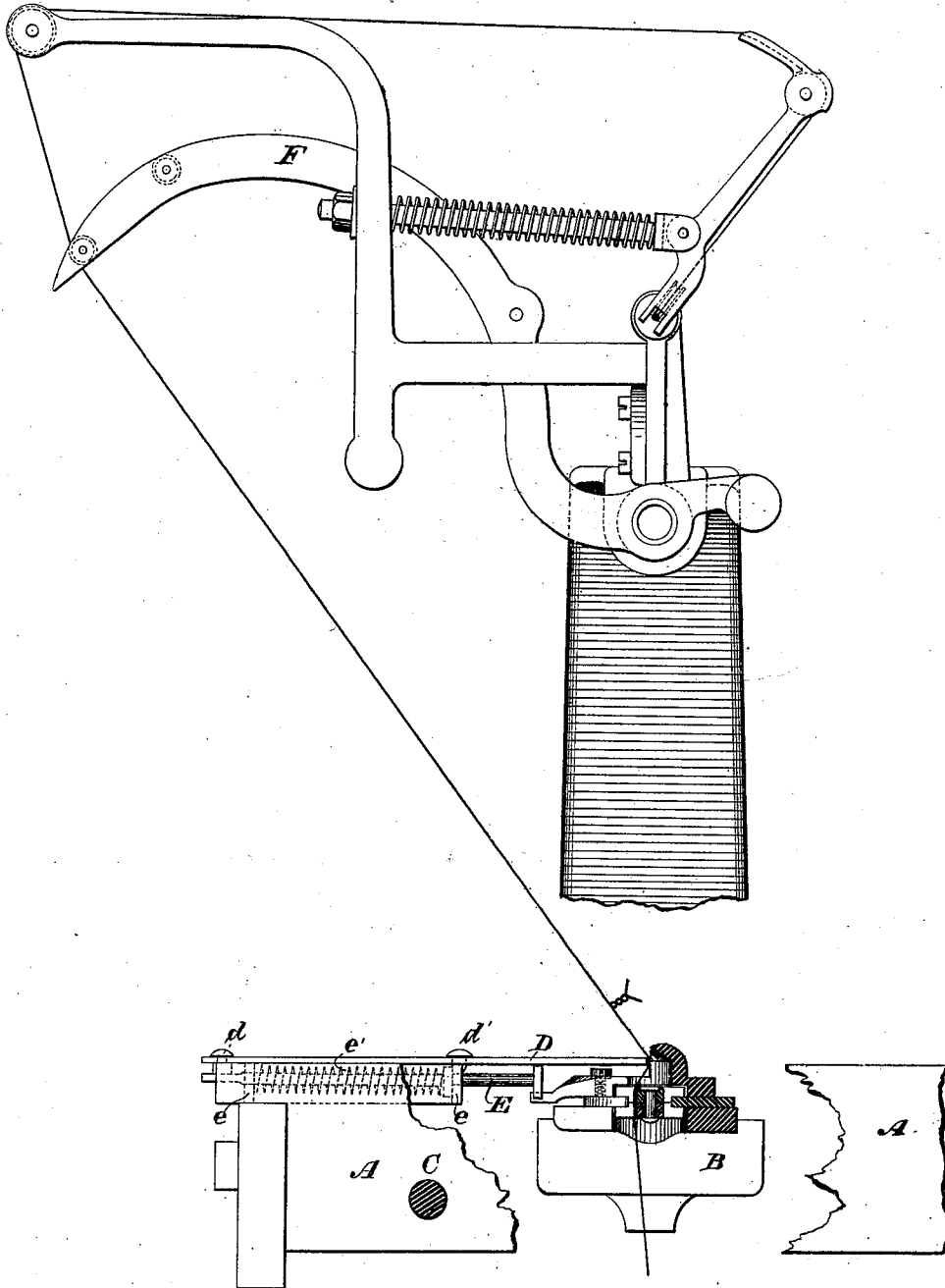

WITNESSES

*Wm. A. Skinkle*  
*Geo. W. Beach*

INVENTOR

*Charles B. Withington*

By his Attorneys.

*Baldwin, Hopkins & Peyton*

C. B. WITHINGTON.  
Grain-Binder.

No. 196,775.

Patented Nov. 6, 1877.

Fig 3

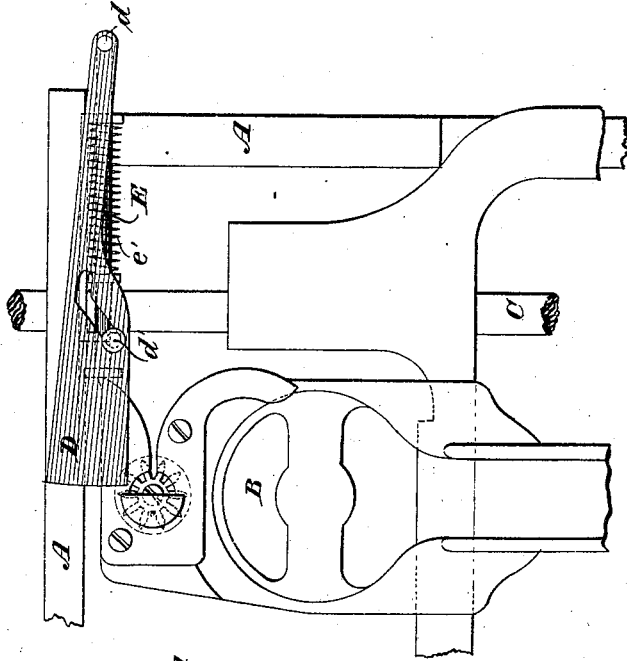

Fig 2.

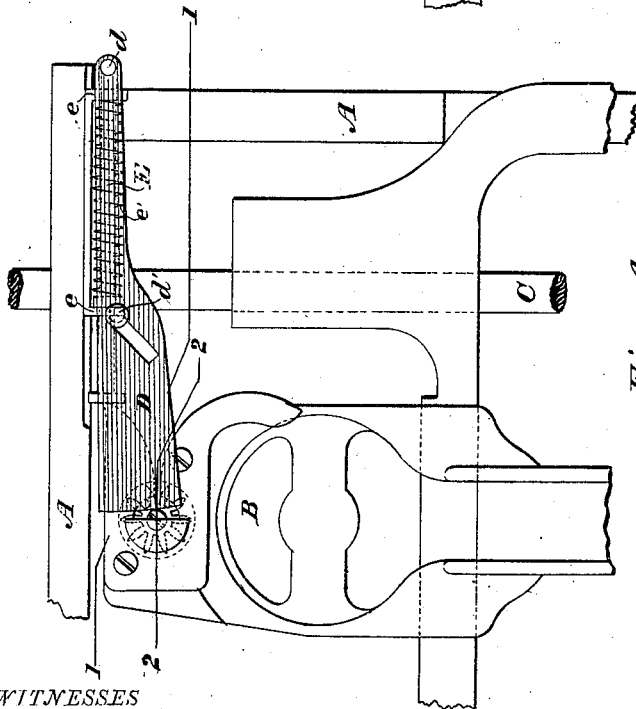
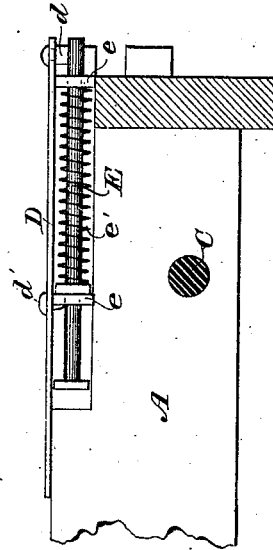

Fig 4.



WITNESSES

*Wm A Skinkle*  
*Geo W Beck*

INVENTOR

*Charles B Withington*

By his Attorneys

*Baldwin, Hopkins & Peyton*

# UNITED STATES PATENT OFFICE.

CHARLES B. WITHINGTON, OF JANESVILLE, WISCONSIN, ASSIGNOR TO C. H. & L. J. McCORMICK, OF CHICAGO, ILLINOIS.

## IMPROVEMENT IN GRAIN-BINDERS.

Specification forming part of Letters Patent No. **196,775**, dated November 6, 1877; application filed May 12, 1877.

*To all whom it may concern:*

Be it known that I, CHARLES B. WITHINGTON, of Janesville, in the county of Rock and State of Wisconsin, have invented certain new and useful Improvements in Grain-Binding Machines, of which the following is a specification:

My invention relates to that class of automatic binders in which the gavel is encircled with wire by a binding-arm, and the ends of the wire united by twisting them between the teeth on the periphery of a rotating twister, in contradistinction to the class in which two wires are twisted in the same slot near the axis of the twister.

In twisters of the class to which my invention more especially relates, it is necessary that one end of the wire should be carried around to the back of the twister, so as to be opposite the other end when the twisting begins.

The object of my invention is to insure the positive entrance of the wire into the slot of the twister, irrespective of the size of the gavel or the condition of the grain, which end I attain by forcing the wire into the slot of the twister or binding-head by a spring push-rod or wire-inserting mechanism. This end may be attained either by moving the twister and binding-head up to the wire-inserting mechanism, or by moving the wire-inserting mechanism up to the twisting-head.

The subject-matter claimed will hereinafter specifically be designated.

The accompanying drawings represent my improvements as applied to the well-known Withington binder, built by C. H. & L. J. McCormick, of Chicago, Illinois, in which the twister and binding-arm reciprocate horizontally in a straight line; but, obviously, my improvements may be adapted to machines of a different construction—such, for instance, as those moving in a vertical or horizontal circular path.

Figure 1 represents a front elevation of so much of my improved apparatus as is necessary to illustrate the subject-matter herein claimed, with the framing partially broken away, and the binder-head partly in section,

on the line 2 2 of Fig. 2, to show its details of construction more clearly. Fig. 2 represents a plan or top view of the binding-head and wire-inserting device, in the relative attitudes they assume when forcing the wire into the twister; and Fig. 3, a similar view of the same after the wire has been inserted, with the wire-insertor moved to one side out of the way of the incoming wire. Fig. 4 represents a side elevation of the wire-inserting apparatus in section, on the line 1 1 of Fig. 2.

The description of the machine will be confined to the parts more immediately relating to the subject-matter herein claimed, the general organization and operation of the machine being shown and described in Letters Patent granted to me March 7, 1876, as No. 174,454, and January 9, 1877, as No. 186,186, and in the application for Letters Patent of Lambert Erpelding, filed January 27, 1877.

The mechanism is mounted upon a binding-frame, A. A binding-head, B, reciprocates upon ways on said frame, being driven by a chain and sprocket-wheels from a driving-shaft, C. In this instance the wire-inserting apparatus is shown as composed of a bar or plate, D, connected at its rear end by a pivot, *d*, with a spring rod or piston, E, movable endwise in bearings *e* upon the binding-frame, and encircled by a spiral spring, *e'*, which tends to keep the device always thrust forward in the position shown in Figs. 1, 2, and 4. In addition to the endwise movement of which the wire-inserting plate D is thus rendered capable, it has a lateral swinging motion around pivot *d*, the extent of which motion is regulated by a diagonal slot in the plate, in which the pin *d'*, fixed on the frame, works.

The operation of the apparatus is as follows: After binding a gavel, the wire-carrying arm F rises and moves backward, leaving one end of the wire in the twister-slot in front of the twisting-pinion. The grain to be bound then passes in upon the binding-platform. As the binding mechanism moves forward to compress the gavel, the wire in the twister-pinion abuts against the square end of the wire-inserting plate D, and is, consequently, positively pressed into the twister, just at the mo-

ment it makes its half-turn, which carries the wire to the back of the twister. By the time this has been done, the parts assume the relation shown in Fig. 3. The continued forward movement of the binding mechanism forces the wire-inserting plate D backward and to one side into the position shown in Fig. 3, where it is held during the descent of the wire-carrying arm, which brings the other end of the wire into the slot of the binding-head or twister, in doing which it slides along the sloping or wedge-shaped inner edge of the wire-inserting plate D. As the binding mechanism is retracted the two ends of the wire are twisted together and cut, and the bundle is discharged in the usual way. The moment the binding-head retracts, the wire-inserting plate is thrown forward into its normal position by its actuating-spring, and the operation above described is repeated.

My invention is adapted for use with either one or two binding-wires.

What I claim as my invention, and desire to secure by Letters Patent, is—

1. A wire-inserting device actuated by a spring, which forces the wire into the twister as the latter makes its half-turn, to bring the

wire to the back of the binding-head, substantially as hereinbefore set forth.

2. The combination, substantially as hereinbefore set forth, of an intermittently-rotating twister-pinion, a wire-carrying arm, and a wire-inserting device, actuated by a spring, whereby the wire is forced into the twister by the wire-inserting device, which then makes way for the passage of the wire-carrying arm.

3. The combination, substantially as hereinbefore set forth, of a reciprocating binding-arm and twister, with an endwise-moving, laterally-swinging wire-inserting device, mounted upon a fixed portion of the binding-frame, whereby the wire-inserting device is actuated by the movement of the binding-head.

4. A wire-inserting device consisting of the combination, substantially as hereinbefore set forth, of the endwise-moving spring-rod, the wire-inserting plate or bar pivoted thereon, and the pin working in a diagonal slot in the bar.

CHAS. B. WITHINGTON.

Witnesses:

L. L. COBURN,  
GEORGE P. BARTON.