

U. CUMMINGS.

Rock-Drills.

No. 196,788.

Patented Nov. 6, 1877.

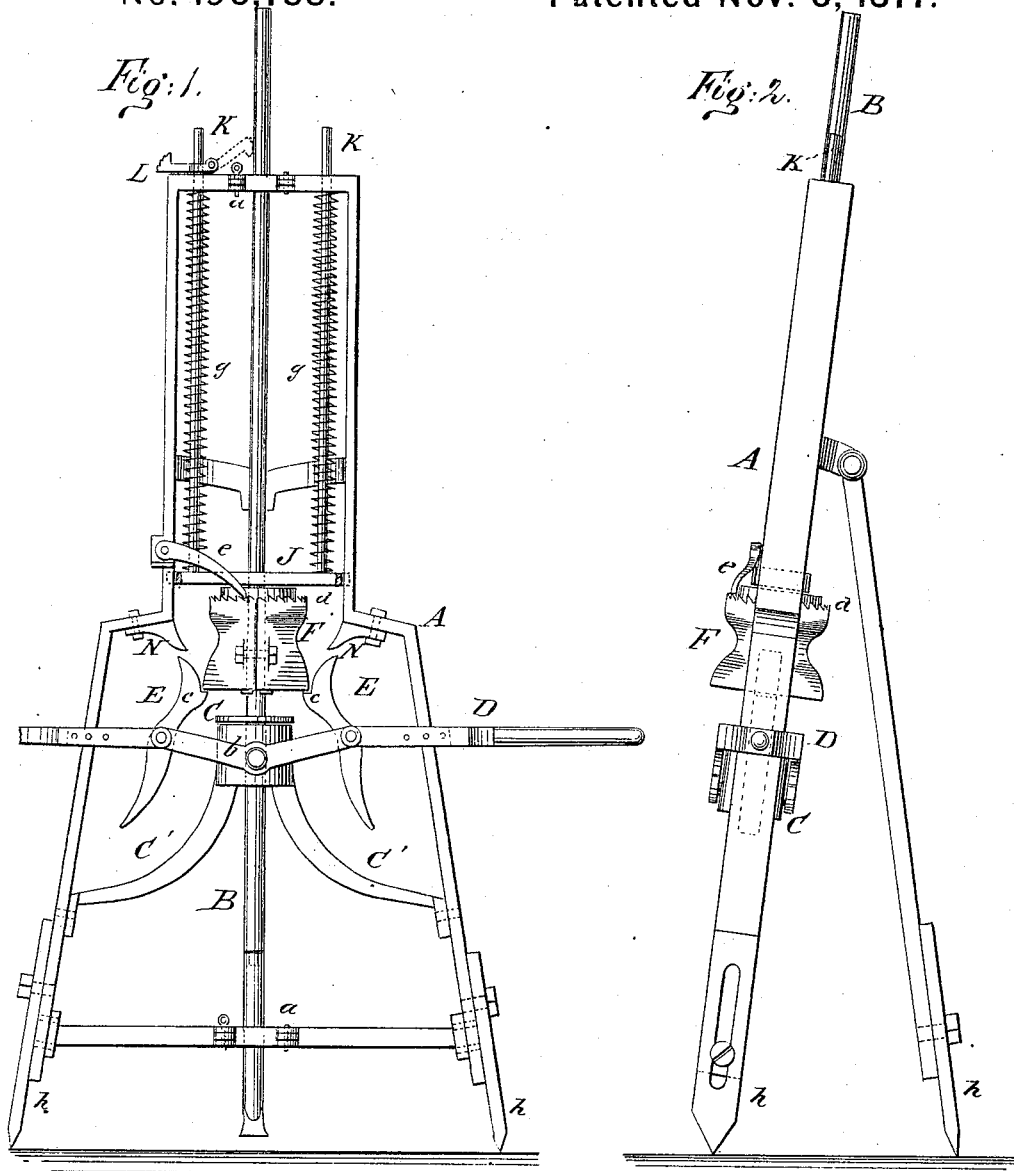
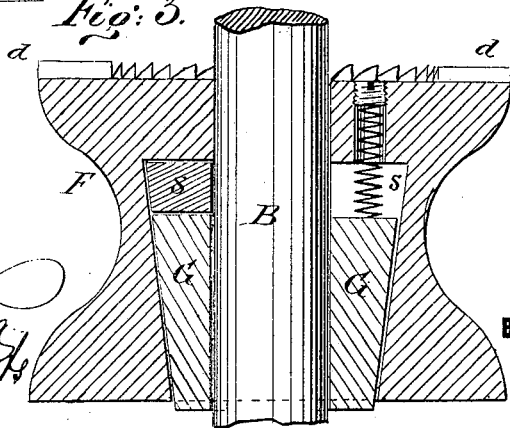

Fig. 3.



WITNESSES:

Chas. Nida
Alex. F. Roberts

INVENTOR:

U. Cummings
BY *Mumford*

ATTORNEYS.

UNITED STATES PATENT OFFICE.

URIAH CUMMINGS, OF BUFFALO, NEW YORK, ASSIGNOR TO HIMSELF AND ARTHUR W. WHITE, OF SAME PLACE.

IMPROVEMENT IN ROCK-DRILLS.

Specification forming part of Letters Patent No. 196,788, dated November 6, 1877; application filed May 21, 1877.

To all whom it may concern:

Be it known that I, URIAH CUMMINGS, of Buffalo, in the county of Erie and State of New York, have invented a new and Improved Rock-Drill, of which the following is a specification:

This invention relates to machinery for drilling rock; and the nature of my invention consists mainly in lifting-dogs and trips for the same, combined with a vibrating lever and a clutch-head applied on a drill-rod, as will be hereinafter explained.

The invention consists in constructing the clutch-head with ratchet-teeth on its upper end, in combination with a pawl which is so arranged on the frame of the machine that the drill-rod will receive intermittent rotary movements during its ascending strokes, as will be hereinafter explained.

In the annexed drawings, Figure 1 is a front view of my improved rock-drill. Fig. 2 is a side elevation of the same. Fig. 3 is an enlarged sectional view of the clutch-head.

Similar letters of reference indicate corresponding parts.

The letter A designates a tripod-frame, and B the drill-rod, which latter is applied in hinged boxes *a a*, so that it can be readily removed when necessary.

The drill-rod may be composed of sections suitably coupled together so that it can be lengthened or shortened at pleasure.

C designates an anvil or buffer, which may be cushioned on top with india-rubber or other elastic substance, and which is substantially supported by arms C' C' secured to the two front legs of the tripod. The drill-rod B is allowed to play freely through the buffer C, which serves as an intermediate guide for this rod.

D designates a double hand-lever which is bent or curved at the middle of its length, and which has its fulcrum at *b* on the buffer, and is allowed to vibrate in a vertical plane.

A pendulum may be attached to the lever D, which can be operated by either one or two persons. Such pendulum would be swung by rods attached on opposite sides of the ful-

crum *b*. Equidistant from the fulcrum *b*, and on opposite sides of it, lifting-dogs E are pivoted, each one of which is curved and constructed with a shoulder, *c*, and a curved toe, as shown.

Upon the shoulders *c* of the dogs rest a clutch-head, F, through which the drill-rod passes. The clutch-head is made of two parts bolted together on the drill-rod, and inside of this clutch are wedges G, acted on by metal or rubber springs *s*, which extend a short distance below the bottom of the head, and operate to engage it with the drill-rod.

On top of the clutch-head F ratchet-teeth *d* are formed, with which a pawl, *e*, engages, and gives intermittent rotation to the drill-rod at each upward stroke thereof.

Directly above the two lifting-dogs E, and fixed to the frame A, are curved tripping-blocks N N, which will disengage one or the other of the dogs from the clutch-block at each upward stroke of a dog.

J designates a follower arranged above the clutch-head F and fixed to rods K K, which are guided by the frame A and surrounded by helical springs *g*, that give the descending strokes to the drill-rod.

L is a serrated holder which is pivoted on top of the frame A, in such relation to the drill-rod that when it is adjusted against this rod it will firmly gripe and support it in an elevated position.

My improved machine is operated by one or two persons grasping the lever D and vibrating it. The dogs engage alternately with the clutch-block and raise the drill-rod to a given height, when the blocks N trip the dogs and allow the drill-rod to descend with considerable force. At each downstroke of the drill-rod the lower exposed ends of the wedges G will strike upon the buffer C, which will disengage them from the drill-rod, and allow it to strike the rock freely and feed itself down to the work. Instantly a dog commences to lift the drill-rod, the wedges G will engage the clutch-head with it.

In practice I shall construct the tripod with feet *h*, which will allow the drill-rod to be ad-

justed vertically, or set at any desired angle with respect to the surface of the rock to be drilled.

Having thus described my invention, I claim as new and desire to secure by Letters Patent—

1. Lifting-dogs E applied to a vibrating lever, D, in combination with tripping devices N, and a clutch-head applied on a drill-rod, substantially as described.

2. In combination with the clutch-head F and raising and tripping devices, the ratchet-teeth *d* and pawl *e*, arranged as described.

URIAH CUMMINGS.

Witnesses:

BERNERD CUNNINGHAM,
ROBERT T. PALMER.