

D. REYNOLDS & J. THORNE. Type-Setting Machine.

No. 196,826.

Patented Nov. 6, 1877.

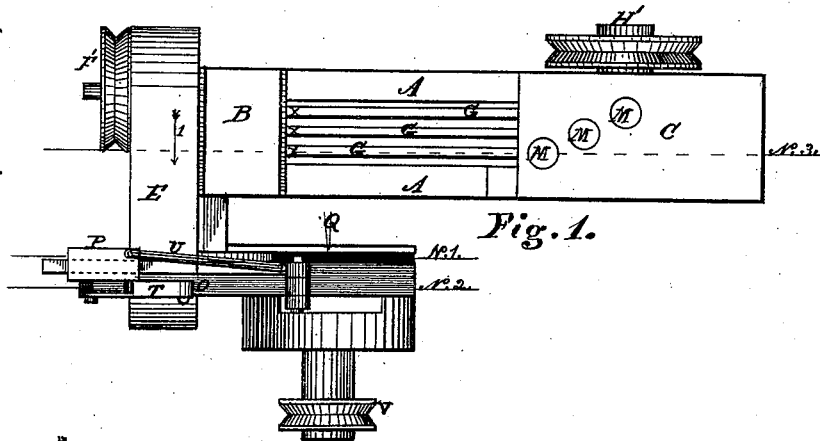

Fig. 1.

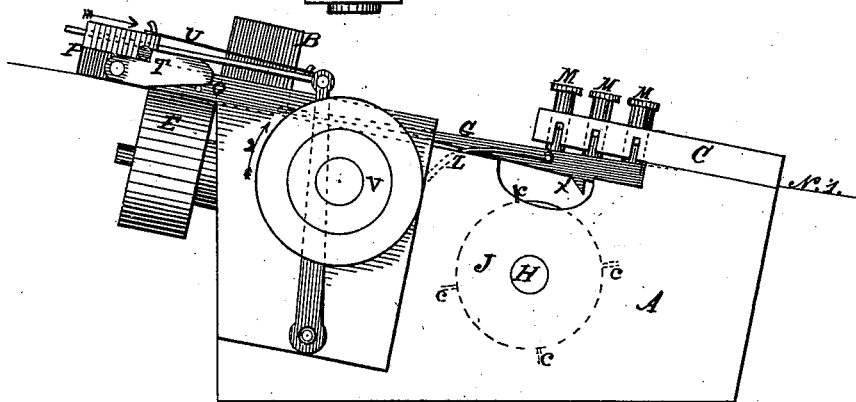

Fig. 2.

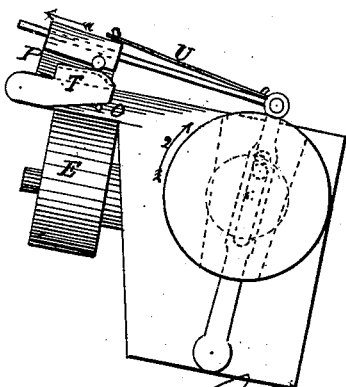

Fig. 3.

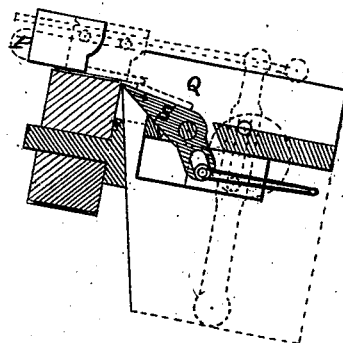

Fig. 4.

Witnesses

Charles Dunham
William F. Selkirk
Alex. Selkirk

Joseph Thorne
Dexter Reynolds.

Inventors.

D. REYNOLDS & J. THORNE.
Type-Setting Machine.

No. 196,826.

Patented Nov. 6, 1877.

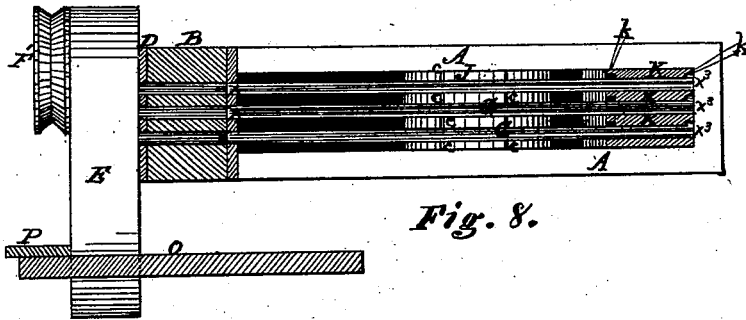
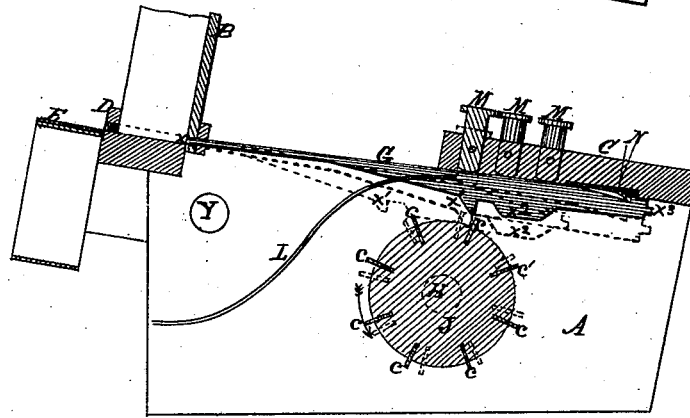
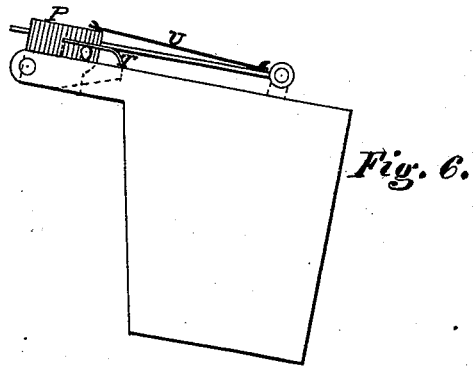
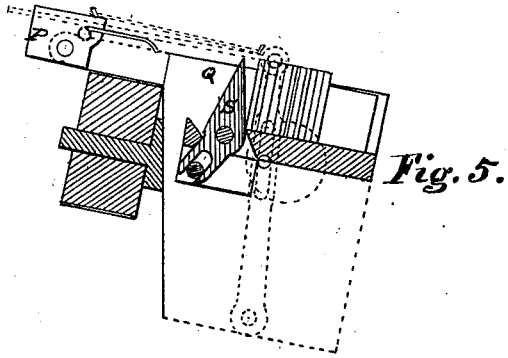

Witnesses

{	Clark Lamborn	Joseph Thorne
	W. H. Linneman	
	Alex. Selkirk	Dexter Reynolds.
	William F. Selkirk	

Inventors.

D. REYNOLDS & J. THORNE.
Type-Setting Machine.

No. 196,826.

Patented Nov. 6, 1877.

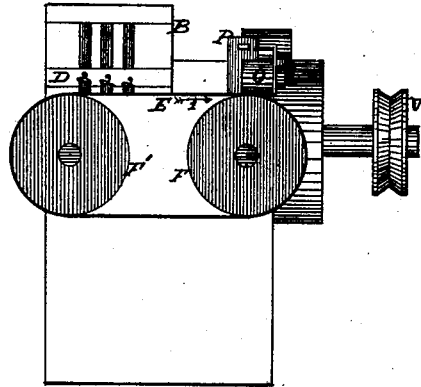

Fig. 9.

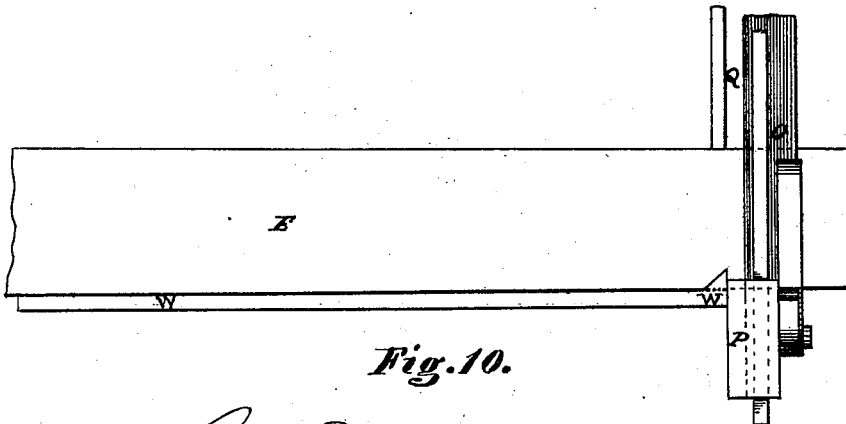

Fig. 10.

Witnesses.

Clark Spink
William F. Seltink
Alex. Seltink
William F. Seltink

Joseph Thorne
Dexter Reynolds.
 Inventors.

UNITED STATES PATENT OFFICE.

DEXTER REYNOLDS, OF ALBANY, AND JOSEPH THORNE, OF PORT RICHMOND,
NEW YORK.

IMPROVEMENT IN TYPE-SETTING MACHINES.

Specification forming part of Letters Patent No. **196,826**, dated November 6, 1877; application filed
March 7, 1877.

To all whom it may concern:

Be it known that we, DEXTER REYNOLDS, of the city and county of Albany, and State of New York, and JOSEPH THORNE, of Port Richmond, Staten Island, and State aforesaid, have invented a new and useful Machine for Setting Type; and we do hereby declare that the following is a full and exact description thereof, reference being had to the accompanying drawings, and to the letters and figures of reference marked thereon, and forming part of this specification, in which—

Figure 1 is a plan view of the machine. Fig. 2 is a side elevation of the same. Fig. 3 is a side elevation of the mechanism for removing the type from the belt. Fig. 4 is a sectional elevation of the same, taken at line No. 1, Fig. 1. Fig. 5 is a sectional elevation taken at the same line, showing another of its operations. Fig. 6 is a sectional elevation taken at line No. 2 in Fig. 1. Fig. 7 is a sectional elevation taken at line No. 3 in Fig. 1. Fig. 8 is a horizontal sectional view taken at line No. 1 in Fig. 2. Fig. 9 is a front view of the machine. Fig. 10 is a horizontal view of a section of the conveying-belt, stop-plate under which it passes, pusher, and flanged plate.

The object of our invention has been the construction of a type-setting machine wherein the case might be arranged to hold the type in lines, side upon side, in channels nearly vertical, so as to retain the advantage of each channel for a given height, holding double the number of type it could if the type were placed therein edge upon edge, whereby the labor of filling the case is reduced over one-half, and still the type, although ejected from the case on their sides, might be ejected one or more at a time, and yet be brought into their proper order and position in the line of composition; so that, by a judicious arrangement of the order of the characters in the case, especially of those known as the "lower-case" letters, with reference to the selecting-keys corresponding thereto, the characters forming words might be set mainly as entires, or else syllabically, instead of letter by letter, as heretofore, thus allowing of the adoption of a system of short-hand type-setting, so to speak, whereby the

rapidity of composition might be greatly increased, with no extra tax on brain or hand; wherein, also, by the use of a continuously-revolving endless belt as a type-conveyer, instead of a reciprocating type-driver, as heretofore used, not only equal results could be obtained with less than half the speed, but the speed would not require to be increased for any increased length of case. The keys could also be touched and type set at any time, instead of intermittingly, and the injurious effects of a reciprocating driver, both on the durability of the type and the machine itself, could be obviated; and wherein, also, the type could be placed in the case for setting without interrupting the work of the compositor, and yet, when set, should be in convenient view of and position for removal by him.

On a suitable support is placed the frame A, (shown in Figs. 1, 2, 7, and 8,) to which is attached the nearly-vertical type holder or case B, with its back toward the key-board C, and having an inclination thereto of about one inch horizontal to every five inches vertical.

The case B is divided into channels of suitable uniform width, and of any desired number and height, as shown in Fig. 9. Each channel is intended to receive a line of type, (all in the same channel being alike,) the type being placed side upon side, with their feet toward the back of the case and their faces outward, so that each column of type may be, in fact, inclosed and separated from the others by having fixed back, bottom, and sides.

A bar, D, (shown in Figs. 7 and 9,) about one-half inch high, is attached to the front of the bottom of the case B, covering up that much of all the channels; but in it openings *a* are cut, opposite the face of the lowest type in each channel, of suitable height and width to allow the passage therethrough of such bottom type only.

Said bar D may be provided with a hinge or other arrangement to allow of its easy removal, so as to permit ready access to the type behind.

On the bar D it is advisable to rest a plate of glass, supported slightly in advance of the faces of the lines of type, and extending suf-

ficiently high up to counteract their tendency to bulge outward under the action of the ejecting-fingers G, hereinafter described.

This glass may be divided into several plates for more convenient and speedy removal.

The back of the case B (shown in Fig. 8) is open at the back, opposite the feet of the lowest type in each channel, sufficient to permit the entrance therethrough of the front ends x of the ejecting-fingers G, as shown in Figs. 1, 7, 8.

The shaft H, (shown in Figs. 2 and 7,) passing through the frame A parallel to and rotating toward the case B, supports a carrier, J, with blades c c' , &c. The greater the number of such blades within reasonable limits, the slower such shaft requires to be revolved to accomplish like results.

A balance-wheel on the shaft H tends to make the action of the carrier J more steady and uniform when several ejecting-fingers G are being carried forward at the same time.

At a suitable distance below the plane of the bottoms of the lowest type in each channel in the case B, and in front of their faces, and parallel to such plane, or at any desired inclination thereto or therefrom parallel to the bar D, and consequently at right angles to the lengths of the type in the case B, is placed the endless belt E, shown in Figs. 1, 2, 3, 7, 8, and 9, (preferably of steel,) passing the whole length of the front of the case B and then over the wheels F F', which, by their action when in motion, impart a continuously-revolving movement to such belt E in the direction of the arrow 1 Fig. 9.

The ejecting-fingers G, (shown in their normal position in Figs. 2 and 7,) rest with their back ends x^3 above and between the guides K, with their front ends x under the back of the case B, and just back of the lowest type therein, and they are held up by the springs L, so that their lugs x^1 x^2 are, when in such normal position, above and beyond the action of the blades of the carrier J.

The keys M, (shown in Figs. 1, 2, and 7,) pass through the key-board C, and their bottoms rest upon the upper edges of the ejecting-fingers G. Such board can be hinged on the side farthest from the case B, so as to be turned over out of the way when access is desired to the parts beneath. The downward movement of the keys M is arrested by their caps coming in contact with the board C, and they are prevented from being thrown too far up by the return of the ejecting-fingers through the spring L, or falling out of their places in the board C when it is turned over, by pins passing through the shafts of the keys moving in slots cut in the under side of the board C, as shown in Figs. 2 and 7.

When a key is depressed the ejecting-finger thereunder is necessarily likewise depressed, and its forward lug x^1 is brought within range of a blade, c , of the carrier J, and carried forward thereby against the action of the spring

L sufficiently far to eject the lowest type in out of the channel of B opposite thereto, onto the belt E, when, by the contact of the lug x^2 with the succeeding blade c' of the carrier, the ejecting-finger is raised up, and permits the spring L to bring it back to its normal position on a plane above the reach of the blades c of the carrier J, and its rebound is prevented by the plate N. (Shown in Fig. 7.)

Each ejecting-finger G is held down in place while making and until it has made its full forward movement, and so as to act independently of its key or the operator, as soon as its bent end x^3 , on the depression of a key, has passed down the recess k' in the guide-plate K the slight distance required to bring the lug x^1 within range of a blade, c , of the carrier J, and been carried forward thereby the slight distance necessary for the end x^3 to catch under the guide-plate K, when the ejecting-finger cannot rise or return to its normal position until the end x^3 reaches the recess k , through which it can ascend and allow of the return of the ejecting-finger by the spring L, the distance between the two recesses k k' being made equal to the length of movement required of the ejecting-finger G to remove a type from a channel in B and deposit it on the belt E. The guide-plate K, with recesses k k' , is shown in Fig. 8.

The plate O (shown in Fig. 1) is placed at right angles to the movement of the belt E and over the wheel F, and so as to permit the belt E to pass freely thereunder, but to arrest all type carried along on the belt.

The reciprocating pusher P (shown in Figs. 1, 4, and 5) removes the type from the belt (as fast as one is removed another taking its place) and discharges them into the channel Q, (shown in Figs. 1, 4, 5, and 10,) where they are raised onto their feet one by one, the first against a slug placed therein and the rest against each other, and shoved into and down a removable channel of any desired length by the arm S, (shown in Figs. 4 and 5,) acting in unison with the pusher P, the pusher P being held down on its forward stroke, but forced back on its return stroke, above and out of the reach of any type on the belt, by the spring-plate T, (shown in Figs. 1, 2, 3, and 6,) the pusher P being made yielding in case of, and to any unusual obstruction on, the belt E by the spring U.

One side of the mouth of the removable channel before mentioned should be made self-adjusting, by a spring or otherwise, so as to slightly pinch a type and prevent the liability of its being thrown too far up by the centrifugal force of the arm S, or, when once raised up, from falling back.

The removable channel into which the type are shoved by the action of the arm S can be made of any desired length, and the support on which it rests be provided with a gong or bell, to be struck by contact of the slug before mentioned therewith, and thus give warning to the compositor that such channel is full.

Near it, convenient to the operator, and either separate from or attachable to and detachable from the machine, can be provided a rack with shelves, onto which the type from the removable channel can be slid as it is successively filled, and from thence the matter can be cut up into lines and justified in the usual manner.

As at high speed a type might sometimes be ejected upon or carried along by the belt E more or less angularly, instead of at right angles to its length, as intended and designed, and so strike the plate O, or in such position come in contact with the pusher P, and be liable to be turned round end for end, or cause an obstruction on the belt E in some other manner, we have found it preferable that in such cases the type should first strike the plate O near their feet, and have for such purpose and others found the advantage of the use, under the belt E, of a bar with a flange slightly curved at the end, as represented by W in Fig. 10.

Motion can be communicated to the belt E from a belt from above or below to the pulley F', and to the rotary carrier J from a like belt to a pulley on the shaft H at H', and to the pusher P and arm S by a like belt to the pulley V; or another shaft, Y, can be passed through the frame A, receiving motion from above or below by a belt, and imparting motion to the wheel F' through miter-gears, and to the pulley at H' and the pulley V by belts to pulleys on such shaft Y, or in any other well-known manner.

The operation of our machine is as follows: Motion being communicated to the belt E in the direction of arrow 1, to the rotary carrier J toward the belt E, to the pulley V actuating the pusher P, and arm S in the direction of arrow 2, the operator, on touching a key, or several at a time, and at any time, the ejecting-fingers G corresponding thereto are depressed, their ends x^3 passing down the recess k' ; the lugs x^1 are, at the same time, brought in range of a blade of the rotary carrier J, as shown by full lines, Fig. 7, and carried forward, the end x^3 of the ejecting-finger being instantly caught under the guide-plate K, and thereafter the operator's hands are free to touch another key or keys. The ejecting-fingers are carried forward by such lug x^1 until their ends x^3 are under the recess k , when, having made their full forward movement, and ejected a type or types onto the belt E, the lugs x^2 are acted upon by the succeeding blade of the carrier J, and they are thus raised up so that their ends x^3 , which are then under the recess k , pass up therethrough, and they are returned by the spring L to their normal position, above the guide-plates K, and out of range of the blades c of the carrier J, and their rebound is prevented by the plate N. The type so ejected upon the belt are carried along it at or about right angles to their lengths until they

are arrested, one or more at a time, the first one by the plate O, and the succeeding ones by those preceding, when the pusher P shoves one after another off the belt E into the channel Q, over the arm S, which, rising on the backward stroke of the pusher P, (which backward stroke is off the belt and above the type thereon,) raises them on their feet, and shoves them into the line of composition in the same order as if set single letters at a time. The touching of keys and setting of type are repeated until the removable channel above mentioned, which may be of any desired length, is full, when the bell is rung, the channel, removed and emptied of its type on the shelves above mentioned, replaced, and its filling resumed. When the shelves are full they can be removed, and the matter cut up into lines and justified in the usual manner, and while one operator is busy in justifying his matter another can be setting type on the machine; or one operator can do all the setting, and another or others all the justifying.

What we claim as new, and desire to secure by Letters Patent, is—

1. The combination of a type-case, B, having a fixed bottom for supporting each column of type, ejecting-finger, and a continuously-revolving endless-belt type-conveyer, E, when so constructed and arranged with relation to each other that single types from any two or more cells of such case can be ejected together therefrom, and thereafter conveyed away upon and by such belt in a position at right angles to their length.

2. A rotary carrier, J, provided with several blades c , in combination with an ejecting-finger, G, provided with a spring, L, to return it to its normal position, and guide-plate K, to automatically hold it down and prevent its too early return.

3. In combination with the ejecting-fingers G, the plate N, to take up their rebound.

4. The combination of the continuously-revolving belt E, stop O, arresting the type, but under which the belt passes, the pusher P, to remove the type from the belt, the channel Q, into which they are discharged, and the arm S, to raise them on their feet and shove them down in line.

5. In combination with the rotary carrier J, the ejecting-finger G, constructed with lug x^1 , by which it is moved forward, and lug x^2 , by which, after it has made its full forward movement, it is raised up free from such carrier, substantially as described.

DEXTER REYNOLDS.
JOSEPH THORNE.

Witnesses to signature of Reynolds:

JAMES F. TRACEY,
WILLIAM JOHNSON.

Witnesses to signature of Thorne:

D. MCLEAN SHAW,
JOSEPH JAUNCEY.