

T. K. KEITH.
 Feed Mechanism for Sewing-Machines.
 No. 196,909. Patented Nov. 6, 1877.

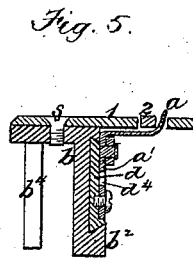
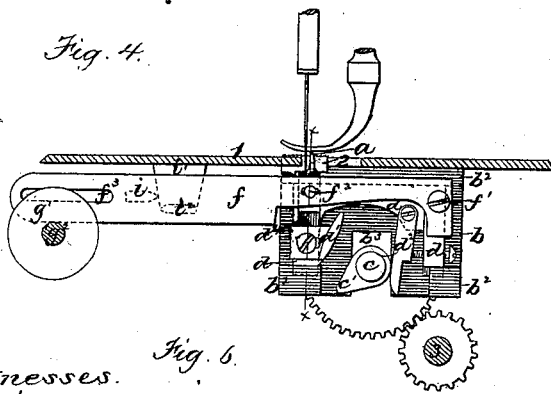
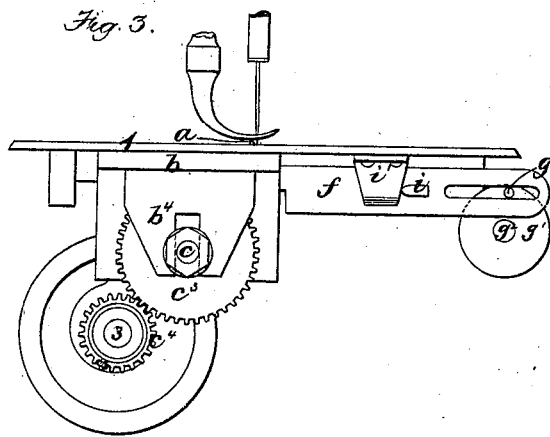
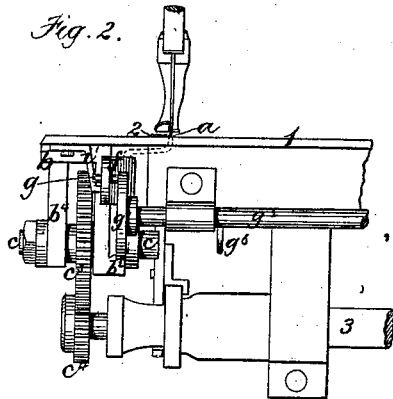
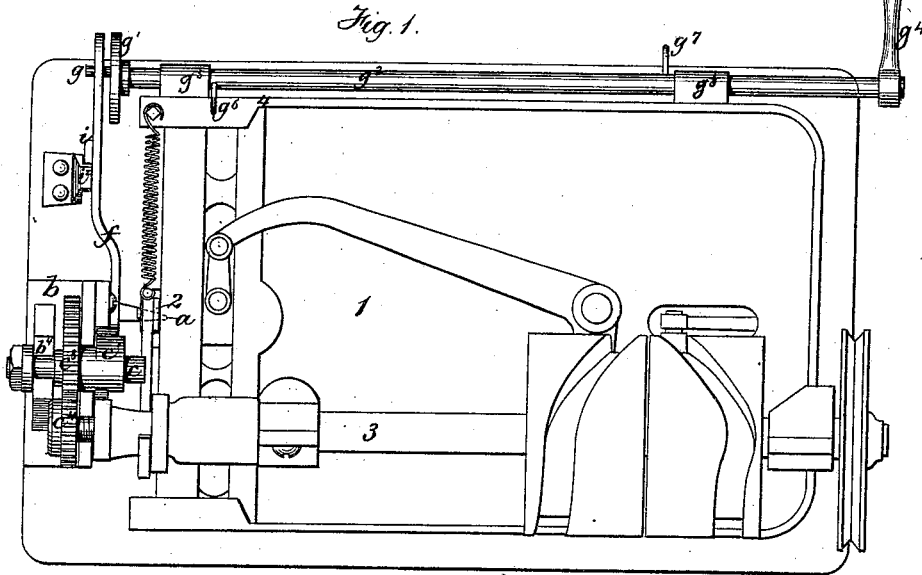

Fig. 6.

Witnesses.
L. W. Fairchild
M. P. Sweetser

Fig. 7.

Inventor
T. K. Keith
 by *Wm. H. Bond*
 Attys.

UNITED STATES PATENT OFFICE.

THOMAS K. KEITH, OF HAVERHILL, MASSACHUSETTS, ASSIGNOR TO MOSES HOW, OF SAME PLACE.

IMPROVEMENT IN FEED MECHANISMS FOR SEWING-MACHINES.

Specification forming part of Letters Patent No. **196,909**, dated November 6, 1877; application filed September 4, 1877.

To all whom it may concern:

Be it known that I, THOMAS K. KEITH, of Haverhill, in the county of Essex and State of Massachusetts, have invented certain Improvements in Sewing-Machines, of which the following is a specification:

In the accompanying drawing, forming a part of this specification, Figure 1 represents a bottom view of a sewing-machine to which my improvements are applied. Fig. 2 represents a front view of a portion of the same. Fig. 3 represents an end view. Fig. 4 represents a transverse vertical section. Fig. 5 represents a section on line *x x*, Fig. 4. Figs. 6 and 7 represent combinations of stitches formed on a sewing-machine provided with my improvements.

This invention is an improvement on a prior invention, for which I obtained Letters Patent dated October 9, 1877, in which a feed-dog adapted to reciprocate in a horizontal direction the work or material being stitched was combined with the primary feeding device, thus causing the stitch-forming mechanism to produce a series of elongated stitches, which the operator could combine in various ornamental designs by turning the work laterally during the operation, the feed-dog acting as a pivot.

The present invention has for its object to combine with the stitch-forming mechanism of a sewing-machine, and with a suitable primary feeding device adapted to propel the work in a single direction, a secondary feed mechanism, operating substantially as described hereinafter, to reciprocate the secondary feed in a substantially horizontal plane, and to raise and lower the same, so that the same machine can form either its ordinary stitches or the elongated stitches, as described in my first application.

It also has for its object to improve the mechanism for operating the secondary feed-dog, and for attaching it to the sewing-machine.

To these ends my invention consists, as a whole, in the combination, with the stitch-forming and work-feeding mechanism, of a secondary feed-dog mechanism, to reciprocate the same in a substantially horizontal plane, and mechanism to raise and lower the same, whereby it is adapted to operate interchangeably

with the ordinary feed, and, when in operation, to reciprocate the work, instead of propelling it in a single direction, substantially as hereinafter specified.

My invention consists, also, in the means provided for attaching the secondary feed-dog to the machine, reciprocating said feed-dog and varying the length of its movement and its nearness of approach to the needle, and raising and lowering it to render it operative and inoperative, all of which I will now proceed to describe.

In the drawing, 1 represents the bed-plate of a sewing-machine having a feeding device for propelling the work in a single direction, the feeding device shown in the present instance being an ordinary four-motioned feed-dog, 2, connected with and operated by the horizontal driving-shaft 3, in the usual manner. *a* represents my extra or secondary pointed feed-dog, which is adapted to be raised and lowered. When raised, the feed-dog *a* projects through the bed 1, above the highest point reached by the feed-dog 2 in its movements, so as to support the work being stitched above the feed-dog 2, and render the latter inoperative; and when lowered, the feed-dog *a* is depressed below the feed-dog 2, and becomes inoperative, allowing the latter to operate as usual. The feed-dog *a* is adapted to be reciprocated horizontally, so that when raised it will reciprocate the work while the latter is being stitched, as in my first invention, above referred to, each motion of the feed-dog *a* being between two successive withdrawals of the needle from the work.

The secondary feed-dog *a* is supported, reciprocated, and raised and lowered by the means which I will now describe. *b* represents a bracket, which is detachably connected by screws *s*, or otherwise, to the under side of the bed 1, at one end thereof. The bracket *b* is provided with a downwardly-projecting portion, which has horizontal dovetail guides or ways *b² b²* and an opening, *b³*, through which passes a shaft, *c*, the latter being journaled in a lug, *b⁴*, formed on the bracket *b*, and provided with a cam, *c¹*. *d d d* represent a cross-head, which is adapted to be supported and to slide horizontally between the guides *b²*, the cross-head being so formed as to pro-

ject downwardly on opposite sides of the cam c^1 . d^1 d^2 represent horizontally-adjustable blocks attached to the cross-head d , and arranged on opposite sides of the cam c^1 , in such manner that as the cam revolves it will bear alternately against the blocks d^1 d^2 , and thus reciprocate the cross-head d , the extent of the movement imparted to the cross-head being determined by the positions of the blocks d^1 d^2 , as will be readily seen. The feed-dog a is provided with a bent shank, a^1 , which is located in a vertical slot, d^3 , in the cross-head, so as to partake of the horizontal motion of the latter, and is adapted to be raised and lowered in said slot, and is supported at different heights by means of a lever, f , which is pivoted at f^1 to the cross-head d , and is connected at f^2 to the shank a^1 . The lever f is provided at its outer end with a longitudinal slot, f^3 , through which projects an arm, g , rigidly attached to a crank or disk, g^1 , on a shaft, g^2 , which is journaled in bearings g^3 g^4 at one side of the bed 1, and is provided with a handle or lever, g^5 , by which it may be rotated, and with stops g^6 g^7 , which consist of curved arms rigidly attached to the shaft, and adapted to bear against parts of the bed 1, and limit the rotation of the shaft g^2 in both directions. When the shaft g^2 is turned, its arm g causes the lever f to swing up and down, according to the direction in which the shaft is turned, thus raising or lowering the feed-dog a . When the feed-dog is raised, as shown in the drawings, the stop g^6 abuts against the bottom of the flange or wall 4 on the under side of the bed 1, and prevents the shaft g^2 from being turned any farther in the direction in which it was turned to elevate the feed-dog; and when the shaft is turned in the opposite direction the stop g^7 abuts against the side of the wall or flange 4 when the dog is sufficiently lowered, and prevents further rotation of the shaft.

From the foregoing it will be seen that the rotation of the shaft c causes the cross-head d and feed-dog a to reciprocate horizontally, the feed-dog being regulated as to its approach to the needle and the length of its movement by the blocks d^1 d^2 . The shaft c is provided with a cog-wheel, c^3 , which meshes with and is rotated by a pinion, c^4 , located on the shaft 3. When it is desired to render the feed-dog a inoperative, the shaft g^2 is turned so as to depress the lever f .

The movements of the feed-dog a are so timed that each movement takes place between two successive ascents of the needle, so that the work is moved between the formation of each stitch and the one following, and thus elongated stitches are formed on the surface of the work, first in one direction and then in the other. The operator is enabled, by turning the work at suitable times, to combine the elongated stitches so as to form rays, as shown in Fig. 7, and by depressing the feed-dog a at times, the elongated stitches

may be arranged in groups, connected by the ordinary stitches formed by feeding the material in the usual manner, as shown in Fig. 6. It is necessary, in forming the pattern shown in Fig. 6, that the feed-dog a should be depressed only when it is at the end of its stroke nearest the needle; and to prevent its depression and also its elevation at other times, I provide the lever f on one side with a projection or lug i , and the bed 1 with a stationary arm or bracket, i^1 , which is provided with a horizontal flange, i^2 , arranged to project under and prevent the vertical movement of the lug i at all times, excepting when the dog a is nearest the needle, as shown in Figs. 1 and 4.

To adapt the sewing-machine to receive my improvements it is only necessary to make screw-holes in the bed 1 for the screws, by which the bracket b and arm i^1 are attached; and a slot for the dog a to reciprocate in, and to drill a hole in the end of the shaft 3 for the screw which attaches the pinion c^4 thereto. Hence the added parts can be readily applied and removed.

I claim as my invention—

1. In combination with the stitch-forming mechanism of a sewing-machine, and with the primary feed 2, adapted to propel the work in a single direction, the secondary feed-dog a and mechanism, substantially as described, for reciprocating the latter in substantially a horizontal plane, and for raising and lowering the same, whereby the dog, when raised, supersedes the primary feed and reciprocates the work, instead of propelling it in one direction, substantially as and for the purpose specified.

2. The cross-head d , carrying the feed-dog a and adjustable blocks d^1 d^2 , combined with the bracket b , having guides b^2 , and the shaft c , having cam c^1 , substantially as described.

3. The combination of the feed 2, the secondary reciprocating feed-dog a , and the horizontally-sliding cross-head d , carrying a pivoted lever, f , secured to and serving to adjust the dog vertically and independently of the primary feed, as set forth.

4. The combination of the longitudinally and vertically movable lever f and feed-dog a with mechanism, substantially as described, whereby the vertical movement of the lever is prevented, excepting when the feed-dog a is at the end of its stroke nearest the needle, substantially as and for the purpose specified.

5. The combination of the lever f with shaft g^2 , provided with pin g and stops g^6 g^7 , whereby its rotation is limited and the lever f raised or lowered, substantially as and for the purpose specified.

In testimony whereof I have signed my name to this specification in the presence of two subscribing witnesses.

THOMAS K. KEITH.

Witnesses:

WILLIAM J. STROHM,

C. F. BROWN.