

J. STRATTON.
Carbureters.

No. 196,946.

Patented Nov. 6, 1877.

Fig. 1.

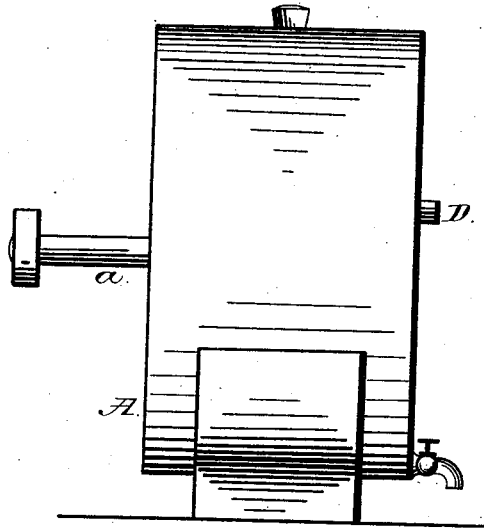

Fig. 2.

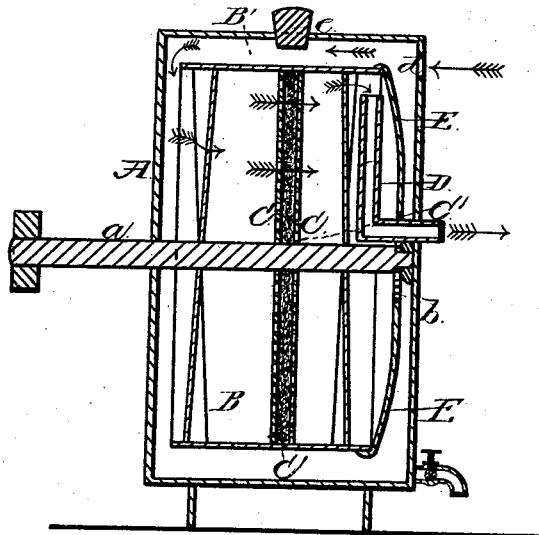
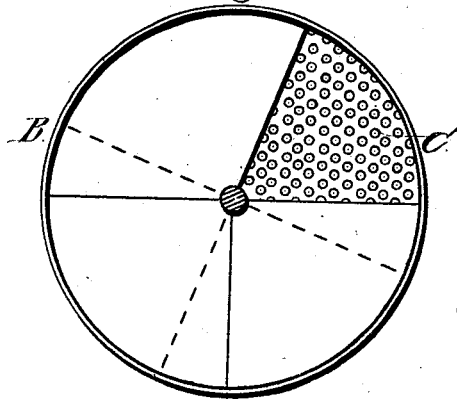

Fig. 3.



Witnesses:

Lewis F. Brouse,
J. E. Shaw.

Inventor:

James Stratton

by

Johann Widenschein
Attorney.

UNITED STATES PATENT OFFICE.

JAMES STRATTON, OF PHILADELPHIA, PENNSYLVANIA, ASSIGNOR TO
OSBORN CONRAD, OF SAME PLACE.

IMPROVEMENT IN CARBURETERS.

Specification forming part of Letters Patent No. **196,946**, dated November 6, 1877; application filed
December 14, 1876.

To all whom it may concern:

Be it known that I, JAMES STRATTON, of the city and county of Philadelphia and State of Pennsylvania, have invented a new and useful Improvement in Carbureters, which improvement is fully set forth in the following specification and accompanying drawings, in which—

Figure 1 is a side elevation of the carbureter embodying my invention. Fig. 2 is a central vertical section thereof. Fig. 3 is an end view of the air-drum and inside thereof.

Similar letters of reference indicate corresponding parts in the several figures.

My invention consists of an air-drum containing perforated diaphragms, between which is confined absorbent material, in combination with an inclosing-case, which receives the carbureting-liquid, and within which the air-drum rotates, whereby said drum likewise constitutes the carbureting-chamber, the fresh-air and carbureted-air pipes being at the same side of the case.

Referring to the drawings, A represents a case, within which is mounted on a horizontal axis, *a*, an air-drum, B, consisting of a cylinder having its heads formed of plates, the adjacent ones of which overlap each other with a space between them, whereby communication is had to and from the interior of the drum, the diameter of the cylinder being less than that of the case, so that there is an intervening space, B'.

Within the drum there are secured two or more perforated diaphragms, C, which extend at a right angle to the axis of the drum, and the space within the diaphragms will be filled or packed with absorbent material C'.

D represents an L-shaped or bent pipe, the horizontal portion of which passes through one wall of the case A and adjacent head of the air-drum, and the vertical portion projects upwardly near the outside of said head.

To the drum, on the outside of the head thereof, adjacent to the pipe D, and inclosing the vertical portion thereof, there is secured a cap, E, which has a central opening, *b*, greater in diameter than the axial shaft *a* and the

horizontal portion of the pipe D, which shaft and portion pass through said opening.

Openings *d* are made in the upper part of the wall of one side of the case A for the admission of air, the wall of the opposite side being imperforate; and an opening, *e*, is made in a suitable part of the case for supplying and replenishing the apparatus with carbureting-liquid, which must fill the case to a line above the opening *b*, so as to seal said opening.

The operation is as follows: Power will be communicated to the shaft *a* in any proper manner in order to rotate the air-drum. Air will be drawn through the openings *d*, and as it cannot enter the sealed opening *b* or the adjacent head of the drum, owing to the closing-cap E, it passes through the space B' over the drum to the opposite side, and enters the openings or spaces of the head of said side.

The carbureting-fluid introduced into the case A enters the drum through the opening *b* of the cap E and openings or spaces of the adjacent head of the drum, so as to saturate the portion of the absorbent material C' in the drum to the level of the fluid or liquid. As the drum rotates, the absorbent material dips into the liquid, so as to be continuously saturated, and as the saturated portion rises above the fluid-level the air passes there-through, and it is thus carbureted, the air also uniting with the vapor from the body of the liquid in the cylinder, after which the carbureted air reaches and enters the pipe D, from whence it may be directed elsewhere for illumination or enriching other gases.

It will thus be seen that an air-drum and carbureting-chamber are combined in one.

It will also be seen that, as the air enters the case A at one side and enters the drum on the opposite side, it traverses the length of the drum before it is discharged, whereby the greatest amount of vapor will unite with the air, the entrance and exit being at the same side of the case, if desired.

I am aware that it is not new to construct a carbureter with two revolving drums communicating with each other, whereby there are

duplication of parts, complication of mechanism, and increase of size.

Having thus described my invention, what I claim as new, and desire to secure by Letters Patent, is—

The case A, with inlet *d* and exit-pipe D, in combination with the single air-drum B, having similar open heads at opposite ends, cen-

tral diaphragms C, inclosing absorbent material C', and closing-cap E, all as and for the purpose set forth.

JAMES STRATTON.

Witnesses:

JOHN A. WIEDERSHEIM,
H. E. HINDMARSH.