

E. LINDSLEY.
 Device for Lighting and Extinguishing Gas.
 No. 196,981. Patented Nov. 13, 1877.

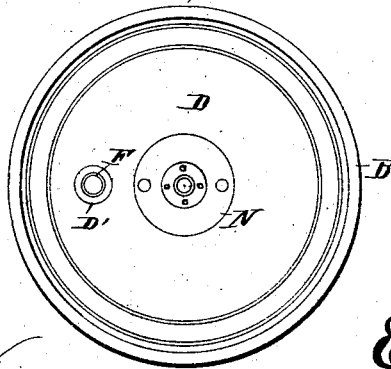
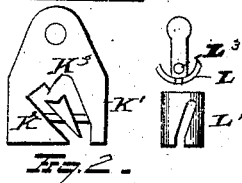
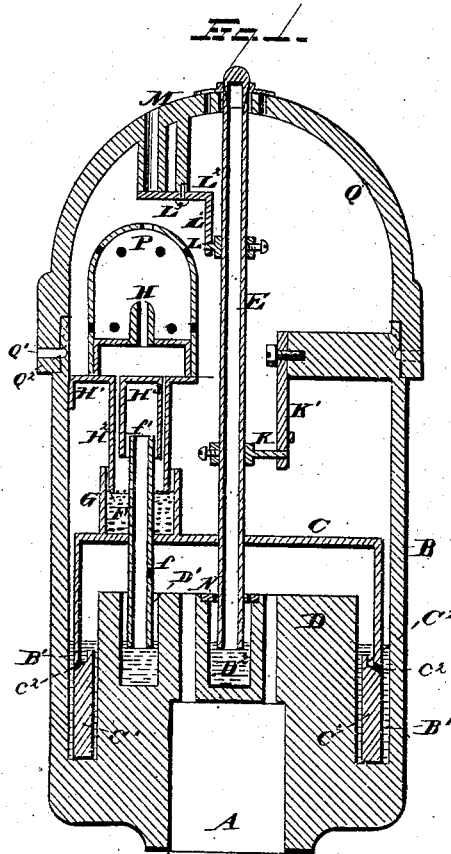

WITNESSES
Edw. S. Nottingham
A. W. Bright

INVENTOR
Edward Lindsley
 By *Segett and Segett*
 ATTORNEY

UNITED STATES PATENT OFFICE.

EDWARD LINDSLEY, OF CLEVELAND, OHIO.

IMPROVEMENT IN DEVICES FOR LIGHTING AND EXTINGUISHING GAS.

Specification forming part of Letters Patent No. **196,981**, dated November 13, 1877; application filed September 13, 1877.

To all whom it may concern:

Be it known that I, EDWARD LINDSLEY, of Cleveland, in the county of Cuyahoga and State of Ohio, have invented certain new and useful Improvements in Gas-Burners; and I do hereby declare the following to be a full, clear, and exact description of the invention, such as will enable others skilled in the art to which it pertains to make and use it, reference being had to the accompanying drawings, which form part of this specification.

My invention relates to an improvement in gas-burners, designed more especially for that kind of gas-burner wherein the gas is lighted and extinguished by varying the pressure within the main.

My invention consists in a cup or shell containing mercury or other sealing fluid, and within that shell or dome a second dome, with its edges depending and dipping into the mercury, so as to be sealed thereby. This inner shell or dome carries pipes, which supply gas to the main burner and to a small day-burner, which maintains a jet during the day-time, the device being so constructed that the pressure of gas within the mains may operate at the proper intervals to let on gas or to extinguish it, as may be desired.

In the drawing, Figure 1 is a longitudinal central section of a burner embodying my invention. Fig. 2 is a plan view of the interior.

A is the pipe, which, for the purpose of this description, I will denominate the "main," from which gas is supplied to the burner. B is the shell or case, which contains a mercury-cell, B'. C is the interior movable dome or shell, which bears the pipes leading to the burners. D is an elevated central portion, containing mercury-cells D¹ and D². E is the main-burner pipe; F, the day-burner pipe. G is a cup, located on top of the interior shell or dome C, and surrounding the pipe F. H is the day-burner, secured to the frame, which is attached rigidly at H¹ to the outer shell or case. H² is a tube leading down around the tube F, dipping into the mercury in the mercury-cup G. H³ is a central tube, closed at its top, and likewise coming down around the day-burner tube F, and terminating above the surface of the mercury. The day-burner tube F is provided at its bottom with a free opening for the

inlet of gas at the proper moment. A short distance above its bottom it is provided with a small orifice, *f*, and at its top with an outlet, *f'*.

The operation of this device is substantially as follows: Gas is introduced through the main A to the interior of the shell C. Now, during the day-time, the bottom of the pipes E and F are immersed beneath the level of the mercury in the mercury-cells D¹ D². This day pressure of gas being low, it does not lift the shell C, but a small jet passes in through the orifice *f*, the size of which may or may not be made adjustable by a screw or other device. The gas passes thence up through the tube F, out of the orifice *f'*, down under the tube H³, and up to the day-burner H, thus supplying this day-burner with a small jet, which is maintained during the day.

When it is desired to light the main burner E at night, proceed as follows: Pressure is introduced through the main A; this exerts pressure beneath the shell C to lift this shell, and with it the pipes E and F. As the pipes E and F are lifted out from the mercury in the cups D¹ D², the gas flows freely through both pipes. As it flows through the pipe E it supplies the main burner at its top. Just as soon as the pipe F has been lifted from the mercury so as to free its end, the gas passing freely through it will cause a long vertical jet to issue up from the day-burner H. Now, as the case or shell rises it carries with it the pin K. This pin operates with a vibrating or pendulous cam, K¹, so that as the shell C rises by an increase of pressure this pin will deflect the cam, so that when the pressure is reduced to a burning pressure the pin will rest in such a position in the cam as to hold the main burner open until, by a subsequent increase and diminution of pressure, the pin is again brought to its original position, and has permitted the pipes to descend sufficiently to close off the gas from all except the day-burner. The rising motion carries the pin L upward, and this pin L, operating upon the arm L¹ of the lever L², turns this lever about its pivotal point L³, thus opening a passage, M, in the top of the dome, through which the long slender jet from the burner H passes, and ignites the main jet from the main burner E. This upward pressure, however, of the gas soon forces the case or

dome C so far upward that the mercury in the cup G rises sufficiently far to close the bottom of the inner tube H³, thus stopping all flow through the tube F, and entirely extinguishing the day-burner.

The cam K¹ (shown detached at the bottom of Fig. 1 of the drawings) is in such a shape that as the pin K rises, by the impulse of the increased pressure in the main, it will find its seat when this pressure is diminished, permitting the pin to rise in the notch K² of the cam. In this condition it will remain until it is desired to turn off the gas in the main. At that time the pressure of gas is again slightly increased, causing the pin K to rise to the point K³ in the cam K¹. The pressure is then diminished, and as the case C drops, this pin K will pass down in the cam K¹ until it again reaches the bottom, or the point from which it started. As the case passes down the end of the tube H³ is soon released from the mercury in the cell G. As soon as it is thus released, the end of the pipe being still free, a strong jet of gas will pass up through the burner H, and out through the opening M, and be ignited from the main burner E. The further descent of the case C will cause the lower end of the main-burner tube E to dip into the mercury, thus cutting off the flow of gas through it. At the same time the lower end of the pipe F will pass into the mercury in the cup D¹, thus cutting off the strong flow of gas through it, permitting it to be fed only through the small orifice *f*, which will maintain but a small flame during the day.

At N is a washer, which serves simply to guide the pipe of the main burner, and is perforated for the free passage of gas.

The depending edge of the interior shell or dome C is enlarged at C¹ along that portion which is submerged beneath the mercury. This is for the purpose of giving greater buoyancy, so that the pressure of gas will operate more readily to lift the dome C. At the same time that this enlarged portion emerges from the mercury its buoyancy will readily diminish, and the pressure of gas is prevented from acting too suddenly upon the case C. This enlarged portion C¹ is hollowed out along its upper edge at C², and is connected by small passages *c*² with the mercury in the cell B'. This recess is for the purpose of scooping up and carrying up for a certain distance a charge of mercury, which charge gradually wastes down through the orifices *c*², thus assisting in preventing the pressure of gas from acting too suddenly upon the interior of the dome C.

The object in preventing this sudden rising of the dome C is as follows: It is apparent that the main burner E, at the time of lighting, is filled with air instead of gas, and gas cannot enter it until the lower end of the pipe emerges from the mercury. It will then take an appreciable time for this air to become expelled, so that a flow of gas may be had from the burner. Now, the long slender jet from the burner is maintained only

from the time the bottom of the tube F leaves the mercury in the cell D¹ until it rises sufficiently to close off the bottom of the tube H². It is therefore necessary to make the motion of the case C sufficiently slow that it shall not pass over this space until all the air has been expelled from the tube E, and free gas is passing from the burner; otherwise the main burner would not be ignited by the jet from the burner H; or, in other words, the burner H would have thrown out its long slender jet and have subsided before the main burner was supplied with gas.

P is a wind-cap set over the burner H. It is provided with an opening at its top for the passage of the long jet, and which assists, with the smaller openings at its side, to ventilate and supply oxygen to the interior flame.

Q is a wind-cap set over the entire device, perforated at its central upper point for the passage of the main-burner pipe. It is also provided with ventilation-holes at the top, and with orifices Q¹, which open into an annular orifice or groove, Q², in the wind-cap Q, and this is at intervals connected with the external air. The object of this indirect communication is to prevent any sudden fluctuations or draft of air upon the interior of the burner, which may extinguish the day-burner.

Instead of locating a tube, H³, within the tube H², the tube H² may be made thick, with an offset on its inner end, which offset shall extend up to the point now shown as the lower end of the tube H³. The space now existing between the separate tubes H² H³ would then be supplied by longitudinal perforations leading in the same way up to the burner H.

What I claim is—

1. In a gas-burner designed for lighting and extinguishing by varying the pressure within the main, the combination of the shell B, provided with the mercury-cell B' and mercury-cells D¹ D², a movable shell or dome, C, bearing pipes E and F, the mercury cup or cell G, and pipes H¹ H², substantially as and for the purposes described.

2. The mechanism for supplying and cutting off gas at the day-burner, consisting of the movable pipe F, provided with small orifice *f*, mercury-cells D¹ G, and tubes H¹ H², substantially as and for the purposes described.

3. The combination, with the mercury-cells and burner-pipes, of the pins K and pendulous cam K¹, whereby the main burner, by an increase and subsequent diminution of pressure, is fixed in an open condition, and by a subsequent increase and diminution of pressure the gas is cut off from the main burner, substantially as and for the purposes described.

4. The combination, with the pin L, secured to an attachment of the movable shell or dome C, of the lever L¹ L² and passage M, substantially as and for the purposes described.

5. The combination, with the wind-cap, of

the ventilation-openings Q^1 and channel or groove Q^2 , substantially as and for the purposes described.

6. In combination with the depending edge of the shell or dome C, the recess C^2 , provided with waste-passages c^2 , substantially as and for purposes described.

7. The pipe F, provided with an open lower end and small perforation, f , in combination with the movable shell C and mercury-cell

D^1 , substantially as and for the purposes described.

In testimony whereof I have signed my name to this specification in the presence of two subscribing witnesses.

EDWARD LINDSLEY.

Witnesses:

F. TOUMEY,

W. E. DONNELLY.