

G. E. EBERHART.
Table-Leaf Support.

No. 197,022.

Patented Nov. 13, 1877.

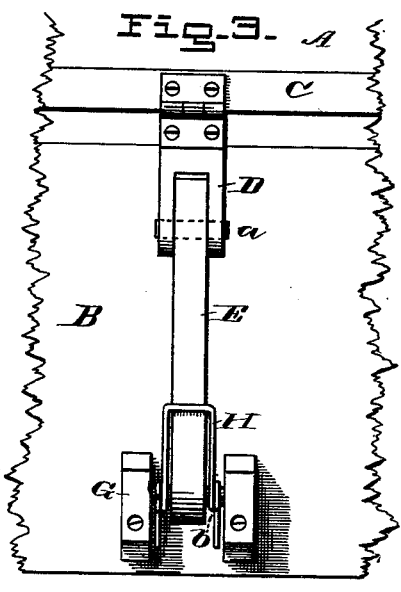
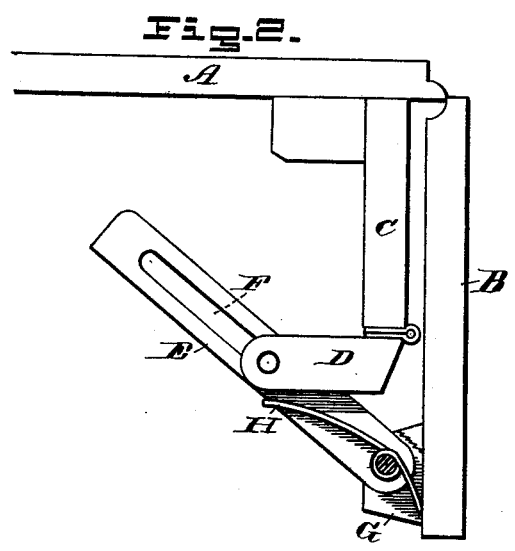
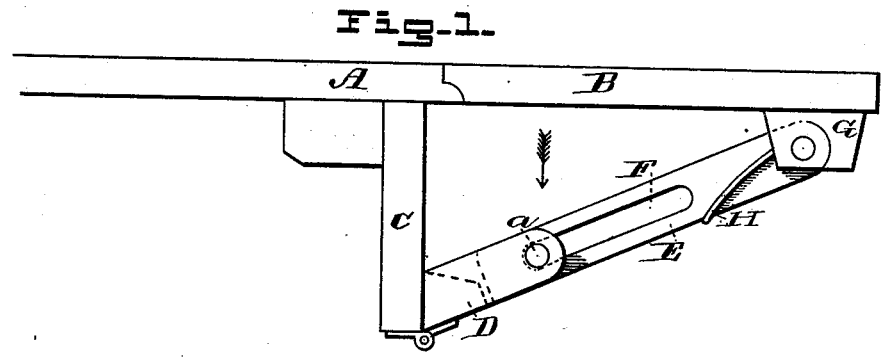

WITNESSES:

Jan. F. Duttamel.
H. B. Brown

INVENTOR:

G. E. Eberhart.
PER
A. J. A. Hot.
ATTORNEY.

UNITED STATES PATENT OFFICE.

GEORGE E. EBERHART, OF CEDAR FALLS, IOWA.

IMPROVEMENT IN TABLE-LEAF SUPPORTS.

Specification forming part of Letters Patent No. 197,022, dated November 13, 1877; application filed April 20, 1877.

To all whom it may concern:

Be it known that I, GEO. E. EBERHART, of Cedar Falls, in the county of Black Hawk and State of Iowa, have invented certain new and useful Improvements in Table-Leaf Supports; and I do hereby declare that the following is a full, clear, and exact description thereof, which will enable others skilled in the art to which it appertains to make and use the same.

The invention consists in a jointed spring-lever, hinged to the side rail and to the folding leaf of a table, and adapted to be straightened out rigidly for supporting the leaf horizontally for use, and capable of folding upon itself when the leaf is not in use and is let down.

In the drawings illustrating my invention, Figure 1 is a side elevation of the device with the leaf extended and supported horizontally. Fig. 2 is a side view of the leaf folded down, showing the lever in position beneath the table; and Fig. 3 is a plan view of the same, looking from below the table-leaf when it is extended.

The letter A designates the table-top; B, the folding or hinged leaf, and C the side rail, of the table. To the lower edge of this rail C is hinged or otherwise jointed a forked arm, D. E is a bar, having a longitudinal slot, F, which bar is secured between the arms of the forked piece D by means of a pin, a, in said piece D, passing through the slot F in the bar. The other end of this bar is jointed between blocks or other pieces G, secured to the folding leaf, or is otherwise hinged thereto, and a spring, H, is so arranged as to exert its force upwardly upon the bar.

In the instance illustrated, the spring H is of wire, coiled about the pin b, used to joint the bar to the blocks G, and having its free end bearing upon the edge of the bar. The spring H, arm D, and bar E constitute a jointed spring-lever.

As is seen in Fig. 1, when the leaf is extended, the arm D and lever E are in line, and their joints are such, when the two are thus placed, as to constitute the said arm and bar a rigid supporting-brace, capable of resisting the downward pressure exerted by the weight of and upon the leaf.

It will be understood that the proper angle for this purpose must be ascertained in arranging the lever.

In order to fold down the leaf, pressure must be exerted upon the lever in the direction indicated by the course of the arrow in Fig. 1, when the joints will yield and the lever will fold up under the table automatically, as shown in Fig. 2, the spring holding the parts up and out of the way.

It will be noticed that, as the table-leaf is raised to its horizontal position, the spring acts to bring the lever into position automatically, thus avoiding any direct manual interference or assistance in its operation.

Having thus fully described my invention, what I claim as new, and desire to secure by Letters Patent, is—

1. The combination of a hinged arm, D, a slotted bar, E, and a spring, H, with a table and its folding leaf, substantially as described.

2. The forked arm D, hinged to the table, the slotted bar E, jointed to said arm and to the folding leaf of the table, and a spring bearing upwardly upon said bar, the whole constituting a jointed spring table-leaf-supporting brace, substantially as described.

In testimony that I claim the foregoing as my own I affix my signature in presence of two witnesses.

GEORGE E. EBERHART.

Witnesses:

J. J. TOLERTON,
J. E. MARKLEY.