

M. C. HULL.
 Ventilator for Chimneys.

No. 197,033.

Patented Nov. 13, 1877.

Fig. 1.

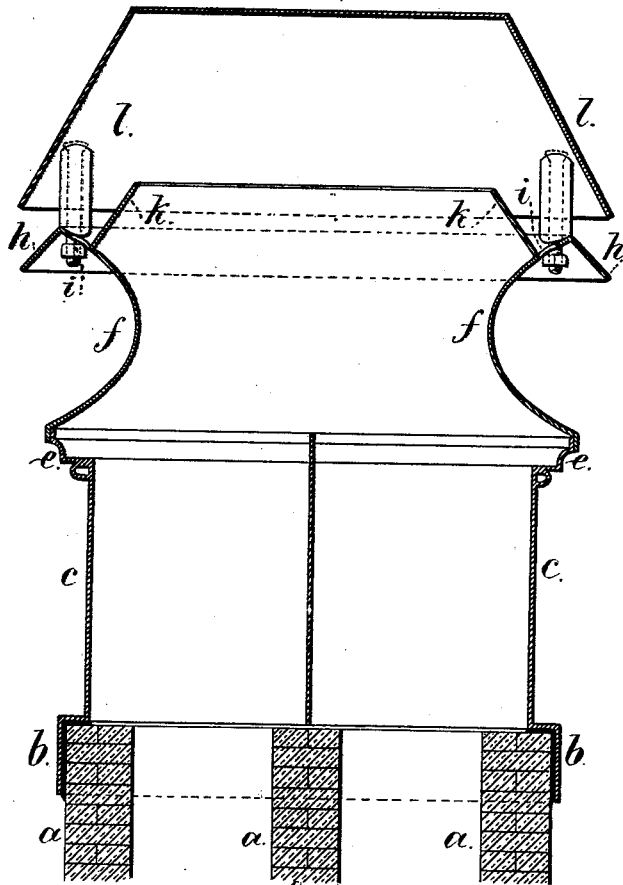
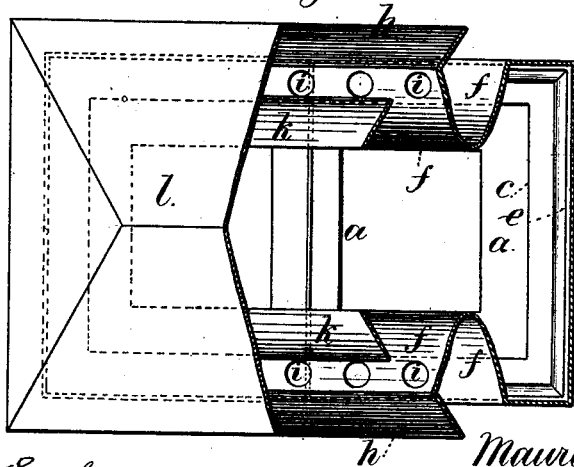

Fig. 2.



Witnesses

*Chas. H. Smith.
 Harold Ferrell*

Inventor.

*Maurice C. Hull.
 per Lemuel W. Ferrell
 atty*

UNITED STATES PATENT OFFICE.

MAURICE C. HULL, OF WEST ORANGE, NEW JERSEY.

IMPROVEMENT IN VENTILATORS FOR CHIMNEYS, &c.

Specification forming part of Letters Patent No. **197,033**, dated November 13, 1877; application filed October 6, 1877.

To all whom it may concern:

Be it known that I, MAURICE C. HULL, of West Orange, Essex county, and State of New Jersey, have invented an Improvement in Ventilators for Chimneys, &c., of which the following is a specification:

This improvement is made with reference to protecting the whole of the top of a brick chimney, so as to prevent injury to the same by the action of moisture and the gases escaping from the flue. At the same time the space for the escaping gases is not lessened and the flue is guarded, so that external currents of air are deflected and the draft of the flue promoted.

In the drawings, Figure 1 is a vertical section of the ventilator, and Fig. 2 is a plan partially in section.

The brick or masonry flue *a* is to be extended above the roof of the building a suitable distance, and the ventilator is of a size to fit upon the same. The base *b* surrounds said brickwork, and rests upon the same, and the body *c* rises from the base, and may be slightly larger than the flues of chimney *a*.

This chimney-top is preferably of cast-iron, galvanized, but may be of sheet metal, pottery, or other suitable material, and the other parts of the ventilator may be of the same material. The chimney-top *b c* should be secured by suitable tie-rods, to hold the same to the brickwork or to the roof, and cement or mortar may be employed to make a tight joint. The tinning or sheet metal of the roof is extended up beneath the base *a*, or it may be brought up outside the box and be soldered onto the metal base. This prevents the risk of leakage, now usual where the edges of the tin pass in between the bricks.

The top of the metal chimney projects, as at *e*, and may be ornamented by moldings, so as to give the required area for the bottom of the ventilator to rest upon.

The sides *f* of the ventilator are concave and parabolic, or formed as segments of a cylinder, and at the lower edges there should be a flange surrounding the moldings *e*. The interior opening or openings between the sides *f* is about the same size as the flue or

flues of the chimney, so as not to check the draft, and these sides *f*, being concave, serve to deflect the external currents of air away from the top of the chimney when blowing in a nearly horizontal direction, and whatever air passes through the openings *i* goes across the top of the flue, and escapes at the other side.

There is a pyramidal rim, *h*, around the upper portions of the sides *f*, and the openings at *i* in the upper part of *f* at the base of the inner pyramidal deflector *k*, to allow the escape of water or moisture that may pass in between the rim *h* and the lower edge of the pyramidal cap *l*, which cap *l* is bolted to the rim *h* or sides *f*, and rises above the chimney to cover the same, and exclude downwardly-acting currents of external atmosphere.

It will be apparent that the opening through the deflector *k* should be of an area corresponding, or nearly so, to the area of the chimney-flues, so as not to obstruct the draft, and, in consequence of the concave shape of the sides *f*, the deflector *k* can stand at the required inclination, and connect to said sides *f* without diminishing the area of the flue.

Any external currents of air that blow in between the rim *h* and cap *l* cannot pass down into the chimney, but go across and out at the opposite side, thus promoting the draft in the chimney.

This ventilator is adapted to chimneys having one or many flues, and under all circumstances the area of the escape for the gases is maintained, instead of being contracted, as has been done in chimney-caps where several flues have one common escape through the cap or cowl.

The pyramidal cap *l* can be removed to give access to all the chimney-flues, and the concave sides *f* give a broad base to the chimney-cap, as well as deflecting the atmospheric currents. Thereby the chimney is covered in a reliable manner without a base, as heretofore used.

I claim as my invention—

1. The concave sides *f*, terminating at their upper portions in the pyramidal rim *h* and deflector *k*, the internal area between the sides

f and deflector *k* corresponding in size, or nearly so, in combination with the cap *l*, substantially as and for the purposes set forth.

2. In combination with the metallic chimney-top made of the base *b*, body *c*, and top *e*, the protecting-cap having concave sides *f*, deflectors *h* and *k*, and cap *l*, as set forth.

3. The combination, with the concave sides *f*, of the deflector *h* and *k*, the internal area between the deflector *k* corresponding, or nearly so, to that between the concave sides, substantially as set forth.

4. In a cap for a flue, the concave sides *f*, forming deflectors for external currents of air, and also a base to rest upon the upper part of the chimney, substantially as specified.

Signed by me this 1st day of October, A. D. 1877.

M. C. HULL.

Witnesses:

GEO. T. PINCKNEY,

CHAS. H. SMITH.