

J. MUSGRAVE, T. F. SHILLINGTON, & J. A. HANNA.
Stoves.

No. 197,161.

Patented Nov. 13, 1877.

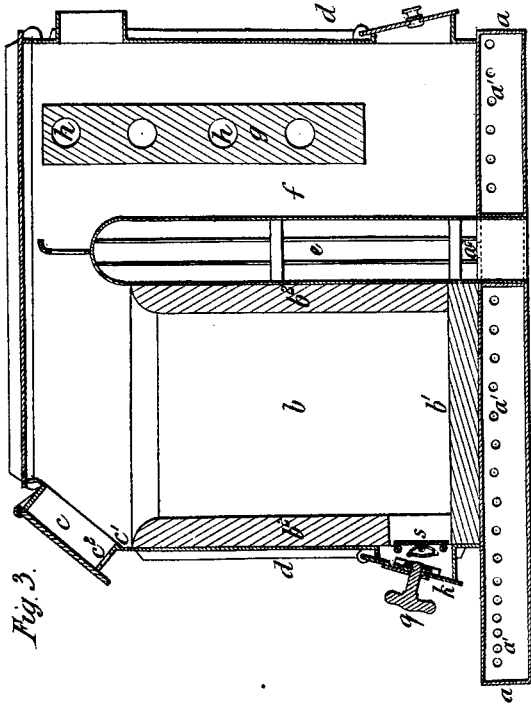

Fig. 3.

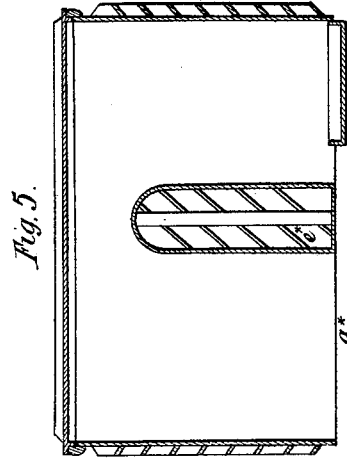

Fig. 5.

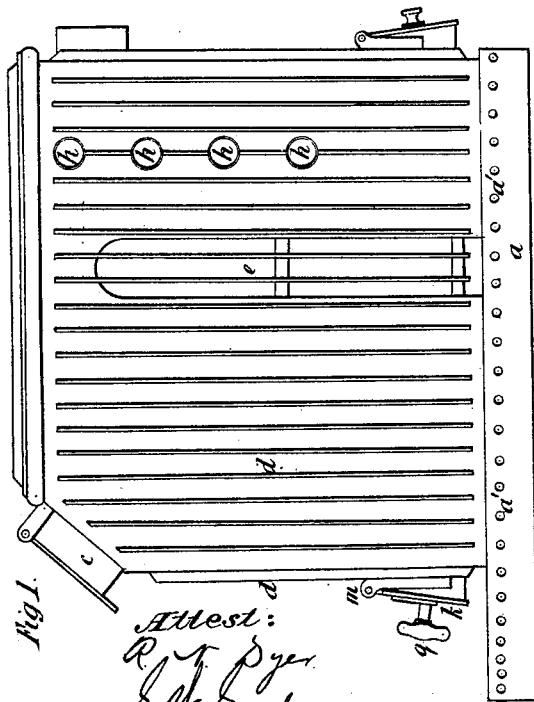

Fig. 1.

Attest:
R. J. P. J.
S. W. Deely

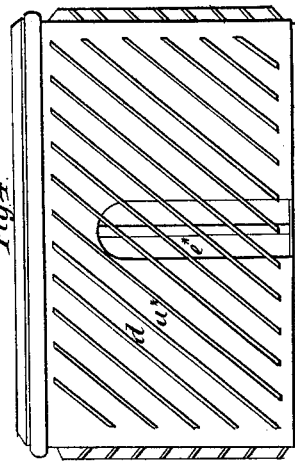

Fig. 4.

Inventors:
James Musgrave,
Thomas F. Shillington
John A. Hanna
by Geo. W. Spence
att'y

J. MUSGRAVE, T. F. SHILLINGTON, & J. A. HANNA.

Stoves.

No. 197,161

Patented Nov. 13, 1877.

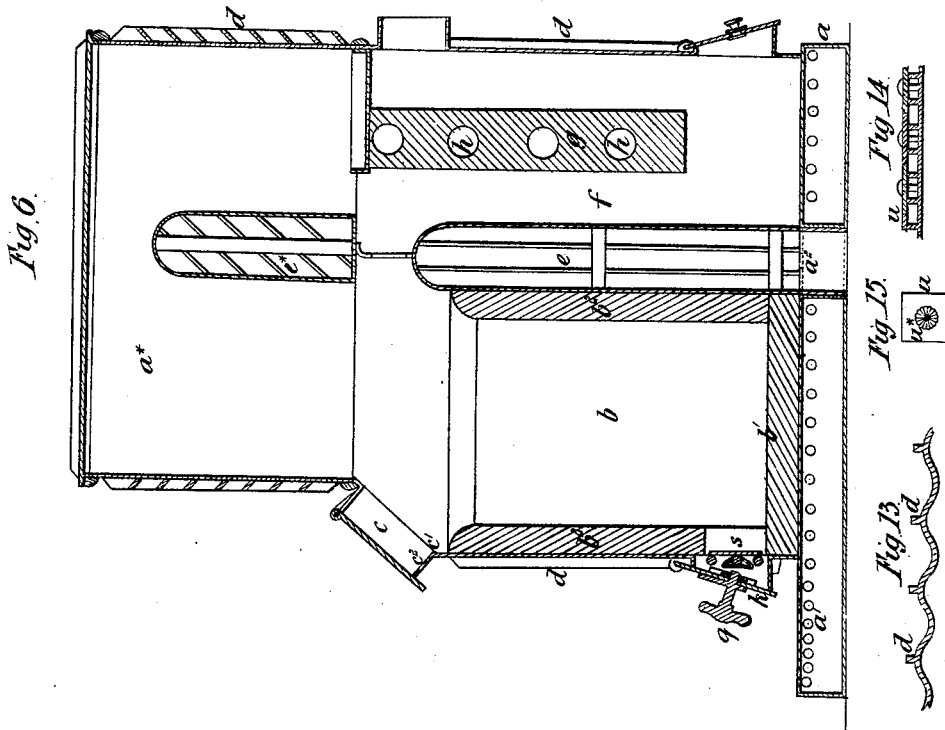

Fig. 6.

Fig. 14.

Fig. 15.

Fig. 13.

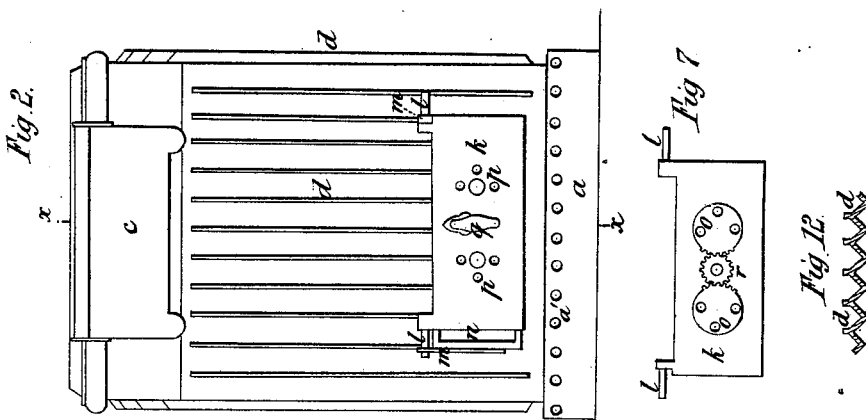

Fig. 2.

Fig. 7.

Fig. 12.

Attest:
 R. T. Dyer
 S. W. Dyer

Inventors:
 James Musgrave,
 Thomas F. Shillington,
 John A. Hanna
 by Geo. W. Dyer & Co
 attys.

J. MUSGRAVE, T. F. SHILLINGTON, & J. A. HANNA.
Stoves.

No. 197,161.

Patented Nov. 13, 1877.

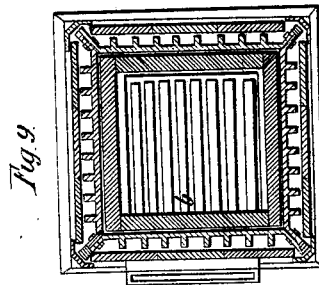
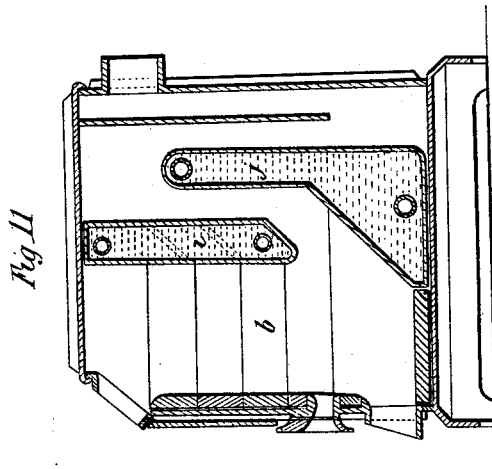
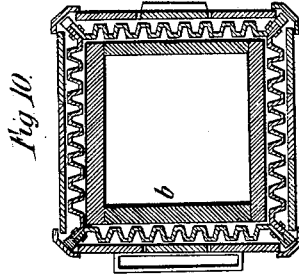
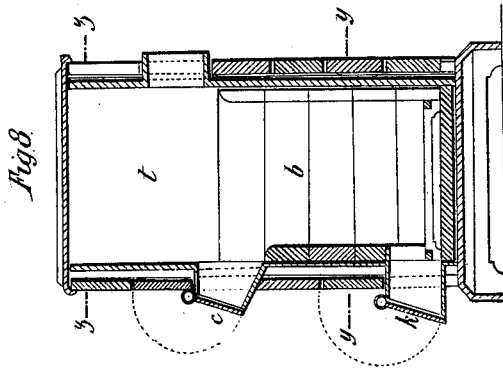

Attest:
R. T. Dyer
S. W. Dyer

Inventors:
James Musgrave
Thomas F. Shillington
John A. Hanna
by Geo. W. Dyer & Co.
attys.

UNITED STATES PATENT OFFICE.

JAMES MUSGRAVE, THOMAS F. SHILLINGTON, AND JOHN A. HANNA, OF
BELFAST, IRELAND.

IMPROVEMENT IN STOVES.

Specification forming part of Letters Patent No. **197,161**, dated November 13, 1877; application filed
May 1, 1877.

To all whom it may concern:

Be it known that we, JAMES MUSGRAVE, THOMAS FOULKES SHILLINGTON, and JOHN ALEXANDER HANNA, all of Musgrave & Co., (limited,) Ann Street Iron Works, Belfast, Ireland, have invented new and useful Improvements in Stoves for Heating Houses and other Buildings, and for other like purposes, which improvements are fully set forth in the following specification.

Our invention relates to improvements in the construction of stoves for heating houses and other buildings, and for other like purposes. The said improvements relate more particularly to the stoves commonly known as the "Musgrave slow-combustion stoves."

Our said invention, and the manner of carrying the same into practice, are illustrated in the accompanying drawings, which we will now proceed to describe.

Figure 1 is a side elevation of a stove constructed according to our said invention. Fig. 2 is a front elevation of the same. Fig. 3 is a vertical longitudinal section on the line $x x$, Fig. 2. Fig. 4 is a side elevation of an additional chamber, designed to be placed upon the top of the stove, (shown in Figs. 1, 2, and 3,) to increase the heating capacity of the same. Fig. 5 is a vertical longitudinal section of Fig. 4. Fig. 6 is a vertical longitudinal section, showing the said stove with this additional chamber. Fig. 7 is an inside view of the air and ashes door detached, and showing the provision thereon for regulating the admission of air to the said stove. Fig. 8 is a vertical section, illustrating a modification of our improved stove. Fig. 9 is a horizontal section of the same on the line $y y$, and Fig. 10 is a horizontal section on the line $z z$, Fig. 8. Fig. 11 is a vertical section, illustrating a further modification of our invention. Figs. 12 and 13 are horizontal sections of portions of the sides of our improved stoves, illustrating modifications in the construction of the same. Fig. 14 is a horizontal section of one side of our stove covered with tiles, as hereinafter described. Fig. 15 illustrates the manner of securing the said tiles.

Like letters indicate the same parts throughout the drawings.

We construct our improved stove with a "water-base," a —that is to say, a hollow base containing water, and on which the stove is mounted, as shown in Figs. 1, 2, 3, and 6. This base a allows the said stove to be used without any danger or inconvenience on a wood floor; and it is provided with holes a^1 and a^2 for the entrance and escape of air, so that it serves as an evaporating-chamber, in which cold air entering mingles with the vapor of the water before passing through heating-chambers, hereinafter described.

In cases where it is not desirable to use this water-base—for instance, when the stove is to be placed on a fire-proof floor—we use an ordinary iron base, and combine or connect with the same an evaporating-pan—that is to say, a pan or tray to contain water, on the top or other convenient part, which evaporates and mixes with the air in the room or building in which the said stove is placed.

We form the fire-chamber b of our improved stoves preferably with a solid or closed bottom, b^1 , of metal or fire-clay slabs or bricks, and line the sides b^2 with the same or similar material. If desired, however, the bottom of the fire-chamber may be formed of grating or grate-bars.

The sides or walls of the stove are constructed of flat plates, with gills or ribs d projecting therefrom, as shown in Figs. 1, 2, and 3; or the said sides may be constructed of corrugated plates, with gills d formed thereon, as shown in Fig. 12 or Fig. 13. By these means we provide for the free expansion and contraction of the sides, and increase the heating-surface of the stove. Or we may construct the sides or walls as shown in Figs. 8, 9, and 10, wherein the part b of the stove, containing the fire, is ribbed or gilled and lined with fire-clay blocks, while the part above the fire is corrugated, and is not, or need not be, so lined.

By referring to Figs. 3 and 6 the internal construction of our improved stoves will be clearly seen. At the back of the fire-chamber b is the air-chamber e , and behind the latter is the second or back chamber f , which is divided into two portions or spaces by the partition g , formed of fire-brick or other suitable

material. In this partition, and extending through the same, we fix tubes *h*, which serve for heating air and distributing the same in the room or building containing the said stove. These tubes may be horizontal or inclined in either direction, as desired.

Instead of the aforesaid air chambers or spaces we may construct water chambers or boilers in our improved stove.

In some instances we reverse the arrangement of the interior of the stove, as shown in Fig. 11—that is to say, we so arrange the said chambers that the draft, instead of passing first upward and then downward, as in the stove above described, passes first under the first boiler *i*, and then up between the first and second boilers *i j*, and then down behind the latter to the chimney. In the latter case they are so formed that the ashes fall forward or toward the front of the stove, and do not obstruct the passage of the smoke, and, moreover, the smoke and gaseous products of combustion are caused to pass down through the incandescent fuel. From the aforesaid boilers hot water may be conducted by suitable pipes to any part of the building for heating, cooking, washing, or other purposes. When it is not necessary or desirable to provide the stove with these water chambers or boilers, they may be replaced by partitions of fire-clay, either solid or containing tubes, extending through them, as above described, or by partitions of iron or other metal, lined with fire-clay.

The door *c*, through which fuel is supplied to the stove, may be placed on the top or front of the same; but we prefer to arrange the said door on an inclined or sloping portion, forming the junction between the top and front of the stove, as clearly shown in Figs. 1, 2, 3, and 6. In the frame *c'* of this door we form holes *c''* for the admission of air, which mixes with and causes the ignition of the carbonic-oxide gas within the fire-chamber; or instead of these holes, and for the same purpose, we arrange air-tubes at the front of the stove, or form air-passages between some of the ribs or gills thereon, which tubes or passages open into the space inside the door-frame.

The air-door *k* (shown detached in Fig. 7) is designed to regulate or control the admission of air to the fuel-chamber, and thereby allow the slow combustion of the stove to be properly maintained. The said door may, for this purpose, have its pins *l*, whereby it is supported in the eyes *m*, of such a length as to allow it to slide endwise, to open and close a space, *n*, for the admission of more or less air; or the said door may have perforated disks *o*, arranged in combination with holes *p* in the door, and operated by a handle, *q*, through the medium of a pinion, *r*, geared with teeth on the said disks; or we may arrange these disks and air-holes at any other convenient part of the stove, or may provide other suitable means for regulating the admission of air to the same.

To prevent the falling of the fuel in the fire-

chamber, we place inside this air-door *k* a grating or set of bars, *s*, hinged to one side of the doorway, so that they will open conveniently, when required, to permit access to the said fire-chamber.

According to another modification of the said invention, we construct our slow-combustion stoves as shown in Figs. 8, 9, 10—that is to say, instead of providing it with smoke and hot-air chambers in the positions above described, we form a reverberatory chamber, *t*, above the fire-chambers. In this reverberatory chamber the gas and smoke revolve, and give out their heat on their passage to the chimney.

If desired, this reverberatory chamber *t* may be divided transversely by a vertical partition into hot-air and smoke chambers. We prefer to have the partition or division plate suspended on pivots, so that it may be moved or shaken, to free it from any ashes or dust that might accumulate on it; or we may construct the said chamber without a partition.

In some instances we cover the sides or walls of our stoves with ornamental iron open-work, or with encaustic or earthenware tiles *u*, fitted and secured upon the gills or ribs, as shown in Fig. 14. We either arrange and secure these tiles in such a manner as to leave apertures at the top and bottom of the spaces between the gills for the admission of air under the tiles and the distribution of the heated air, or we perforate the tiles for the admission and escape of air for warming the building or apartment containing the said stove. We prefer to attach the said perforated tiles by means of a screw through the center of each tile. The head of the screw forms a metal rosette, as shown at *u**, Fig. 15.

In some instances we insert in the door, or in other convenient portions of the stove, pieces of mica, as in other stoves; but we prefer to use tempered or annealed or strong glass, through which the fire will appear, and which will give the stove a bright and cheerful appearance; and the use of this glass, instead of mica for this purpose, forms a part of our invention.

With reference to the upper portion or chamber *a**, (shown detached in Figs. 4 and 5,) when the same is to be used in the stove shown in Figs. 1, 2, and 3, the top plate or cover of the latter is removed, and the said upper chamber is fitted in its place; but we wish it understood that although we have more particularly described this upper chamber as an addition to the said stove, and capable of removal therefrom, so that the said stove may be used without it, as in Figs. 1, 2, and 3, or with it, as in Fig. 6, yet, if desired, we may construct the said stove separately in either form—that is to say, without any provision for the reception of an upper chamber, or we may make such upper chamber a permanent part of the stove.

We claim as our invention—

1. The combination, with a heating-stove having a combustion-chamber and rear descending and ascending draft-chambers, of the

rectangular detachable portion *a**, divided into two connecting chambers by the air-space *e**, and adapted to join the combustion and the draft chambers when in position on the stove, constructed and arranged substantially as described and shown.

2. In a heating-stove, the combination of the water-base, the front fire-chamber, the back fire-chamber, the intermediate air-space *e*, the tubes *h*, and the air-door *k*, substantially as and for the purposes set forth.

3. In a slow-combustion heating-stove, substantially as described, the combination, with the fire-chamber *b*, of the draft-opening at the

bottom of same, the grating or bars *s* in said opening, and the hinged air-door *k*, all constructed and arranged substantially as described and shown.

JAMES MUSGRAVE.
THOMAS FOULKES SHILLINGTON.
JOHN ALEXANDER HANNA.

Witnesses:

SAML. M. WILLIAMS,
*Clerk at U. S. Consulate,
7 Donegal Square, South Belfast.*
JOSEPH MCCrackEN,
Merchant, 18 Linen Hall Street, Belfast.