

W. F. VAN KEUREN.  
Harness Buckle.

No. 197,186.

Patented Nov. 13, 1877.

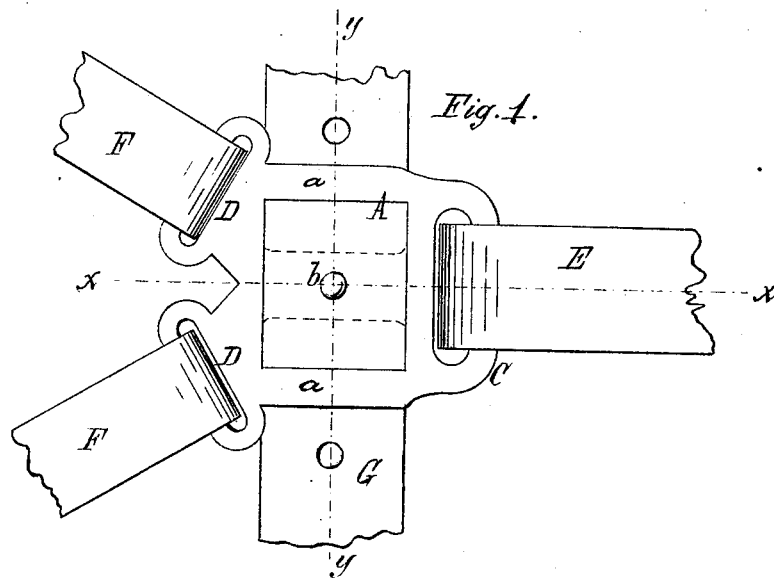

Fig. 2.

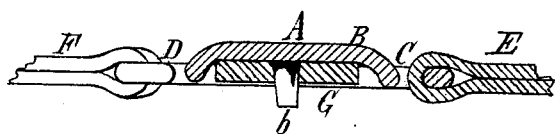

Fig. 3.

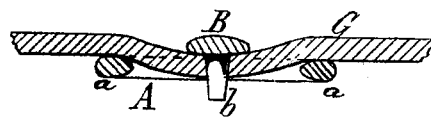
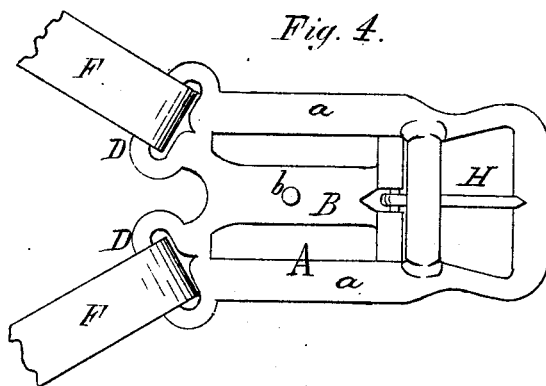

Fig. 4.



Chas. J. Buchheit  
George H. Snyker } Witnesses

Wm. F. Van Keuren Inventor  
By Edward Wilhelm  
Attorney

# UNITED STATES PATENT OFFICE.

WILLIAM F. VAN KEUREN, OF BUFFALO, NEW YORK, ASSIGNOR OF ONE-FOURTH HIS RIGHT TO PRATT & LETCHWORTH.

## IMPROVEMENT IN HARNESS-BUCKLES.

Specification forming part of Letters Patent No. **197,186**, dated November 13, 1877; application filed March 17, 1877.

*To all whom it may concern:*

Be it known that I, WILLIAM F. VAN KEUREN, of the city of Buffalo, in the county of Erie and State of New York, have invented certain new and useful Improvements in Harness-Buckles, which improvements are fully set forth in the following specification, reference being had to the accompanying drawings.

My invention relates to a buckle or metallic connection for permanently securing the ends of the holdback-straps and martingale to the belly-band.

In a team-harness the forward ends of the holdback-straps, passing along the flanks of the horse, are connected under the belly of the horse, by a metallic ring or otherwise, with the rear end of the martingale or neck-yoke strap. The latter and the holdback-straps are generally disconnected from the belly-band, so that in unhitching the horse the holdback-straps and martingale frequently become separated from the main portion of the harness.

The object of my invention is to obviate this difficulty by providing a metallic connection which permanently unites the ends of the holdback-strap and martingale with the belly-band.

The nature of my invention will be fully understood from the following description.

In the accompanying drawings, Figure 1 is a plan view of my improved buckle. Figs. 2 and 3 are sections, respectively, in lines *x x* and *y y*, Fig. 1. Fig. 4 is a plan view of my improved buckle in a slightly-modified form.

Like letters of reference refer to like parts in each of the figures.

A represents the frame of the buckle, provided with a longitudinal bar or plate, B, arranged centrally within the frame A, and provided with a downwardly-projecting stud or pin, *b*. C is a loop arranged at the front side of the frame A, for connecting the neck-yoke

band or martingale thereto. D D represent two smaller loops arranged at the rear side of the frame A, for securing the ends of the holdback-straps to the same. The two loops D D are preferably arranged at an angle with reference to the frame A, or about at right angles to the direction of the holdback-straps, as clearly shown in the drawing. E represents the neck-yoke strap or martingale, secured to the loop C; and F F, the holdback-straps, connected with the rear loops D D. G is the belly-band, passed through the frame A, above the side bars *a* thereof, and underneath the central bar B, the stud *b* entering one of the holes with which the belly-band is provided, as clearly represented in Fig. 3.

By this means the buckle is firmly secured to the belly-band, and the ends of the neck-yoke strap and holdback-straps permanently connected therewith, and the respective straps kept in their proper places when the harness is in use, as well as in unhitching the horse.

If desired, the frame A may be provided at its front end with a buckle, H, as shown in Fig. 4, instead of the loop C, for connecting the neck-yoke strap to the frame A; but I prefer the simpler form shown in Figs. 1 and 3.

My improved buckle is readily cast, of suitable metal, at comparatively small expense, and is of great convenience in use.

Having thus fully described my invention, what I claim as new, and desire to secure by Letters Patent, is—

A harness-buckle composed of the frame A, provided with central bar B, having a stud, *b*, and a front loop, C, and two angular rear loops, D D, substantially as and for the purpose hereinbefore set forth.

W. F. VAN KEUREN.

Witnesses:

EDWARD WILHELM,  
GEORGE H. SYKES.