

C. J. ADDY.
Sole-Edge Trimming-Machine for Boots and Shoes.

No. 197,306.

Patented Nov. 20, 1877.

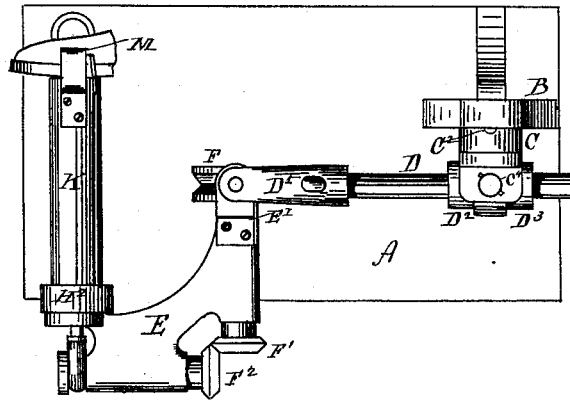

Fig. 1.

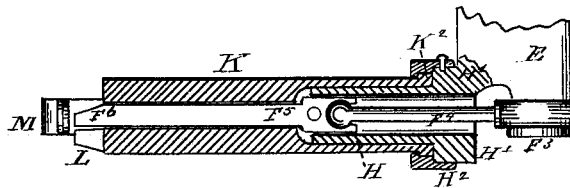

Fig. 3.

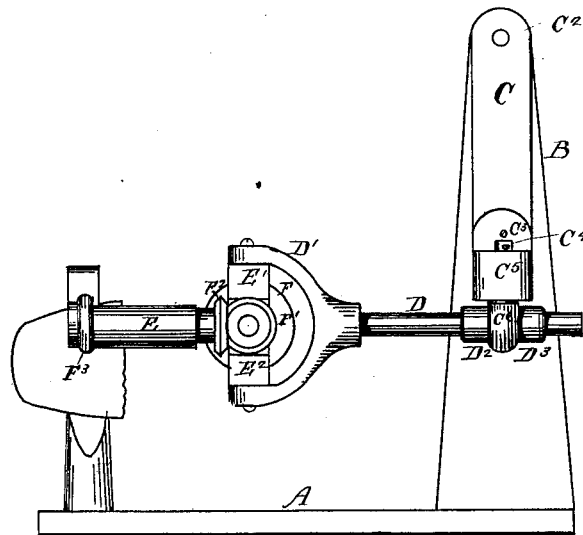

Fig. 2.

WITNESSES.

Franklin Parker.
John Evans

INVENTOR

Charles J. Addy
Per William Edison Atty

UNITED STATES PATENT OFFICE.

CHARLES J. ADDY, OF BOSTON, MASSACHUSETTS, ASSIGNOR OF ONE-HALF HIS RIGHT TO ESSEX S. ABBOTT, OF SAME PLACE.

IMPROVEMENT IN SOLE-EDGE-TRIMMING MACHINES FOR BOOTS AND SHOES.

Specification forming part of Letters Patent No. **197,306**, dated November 20, 1877; application filed October 16, 1877.

To all whom it may concern:

Be it known that I, CHARLES J. ADDY, of Boston, in the county of Suffolk and State of Massachusetts, have invented a new and useful Improvement in Boot and Shoe Sole Edge Trimming Machines, of which the following is a specification:

The present invention relates to an improvement on the machine for which Letters Patent of the United States of America were granted to myself and Essex S. Abbott September 21, 1875, No. 167,816, entitled "Shoe-Edge-Trimming Machine;" and consists in so adapting the knife-operating mechanism that it may work in a movable case or frame, which also serves as a handle for the user.

The power for driving the knife mechanism may be transmitted through belts and gears, in connection with jointed arms, or by a flexible shaft.

The exact nature of my invention may be best understood by reference to the specification and drawings.

The object of the invention is to so arrange the vibrating cutter and its mechanism that the operator may apply the knife to any part of the edge of the sole, the boot or shoe being held by a jack.

In the drawings, Figure 1 is a plan of my invention. Fig. 2 is a side elevation. Fig. 3 is a section through the handle, showing the knife and its driving mechanism.

A, Figs. 1 and 2, represents the base, to which I attach the working parts of my machine. B is a standard, upon which I hang the swinging link C, by a pivot, C². To the lower end of the link C I attach the swing-block C⁵, by a pivot, C². In the block C⁵ I hang the swiveling eye-piece C⁴ C⁶, through the eye of which I pass the end D of the forked piece D D¹, in such a manner that it (the forked piece) may be free to turn, but is held longitudinally by the collars D² D³. In the forked piece D D¹ I hang the head-piece E. (See Figs. 1 and 2.) The head-piece E is pivoted to the forked piece D¹ at the ears E¹ E². (See Figs. 1 and 2.)

It may be seen that by the above system of arms and joints the head-piece E is free to move in all directions, and that, by attaching pulleys at the joints, and at C², Fig. 1, motion may be transmitted to the knife-driving mechanism, or the pulleys may be omitted, and the knife-driving mechanism be operated by a flexible shaft.

H¹ H¹ H represent a tubular piece extending from the part E. (See Fig. 3.) Upon this tube the handle K rotates, and is held by a union joint formed by the nut H² and the fillet K².

Within the handle K I form a slot for the knife-shank F⁵ to slide, (see Fig. 3,) F⁶ being the knife proper, which has a block and rand-guide M to strike upon, as in the patent above referred to. L is a flat guide or guard made fast to the handle and placed just back of the knife.

The knife F⁶ F⁵ is driven by the pitman F⁴, which is connected to it by a ball-and-socket joint, (see Fig. 3,) and an eccentric at F³, which is driven by a shaft from the gear F², the gear F² being driven by the pulley F, through a shaft and the gear F¹, as shown, or if desirable, a flexible shaft may be connected directly to the shaft of the gear F².

Having now described the construction and operation of my invention, what I desire to secure by Letters Patent is as follows:

1. The combination of the swiveling tubular handle K and the vibrating knife F⁵ F⁶, operating within the handle, substantially as described, and for the purpose set forth.

2. The combination of the vibrating knife F⁵ F⁶, handle K, and knife-driving mechanism F³ F⁴ with the movable head E, all operating substantially as described, and for the purpose set forth.

CHARLES J. ADDY.

Witnesses:

NATH. EVANS,
WILLIAM EDSON.