

W. A. WICKS.
Sheet-Metal-Can Machines.

No. 197,440.

Patented Nov. 20, 1877.

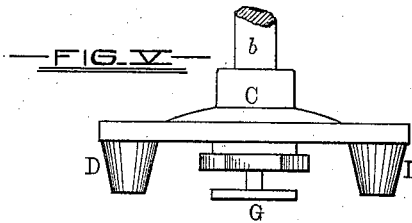
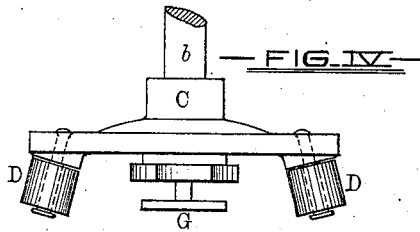
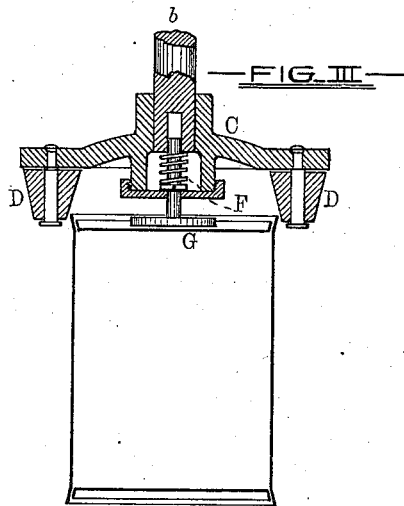
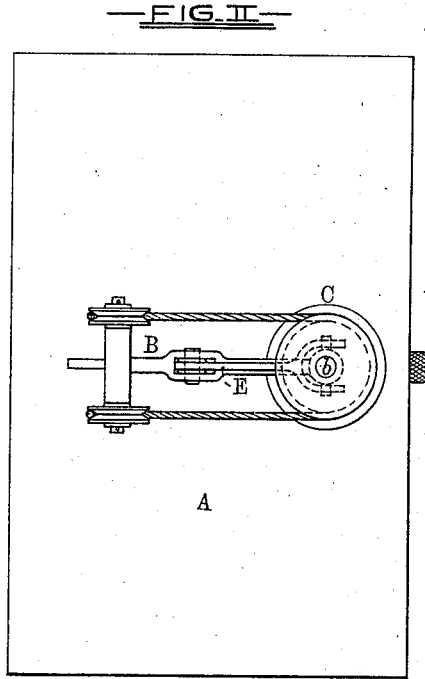
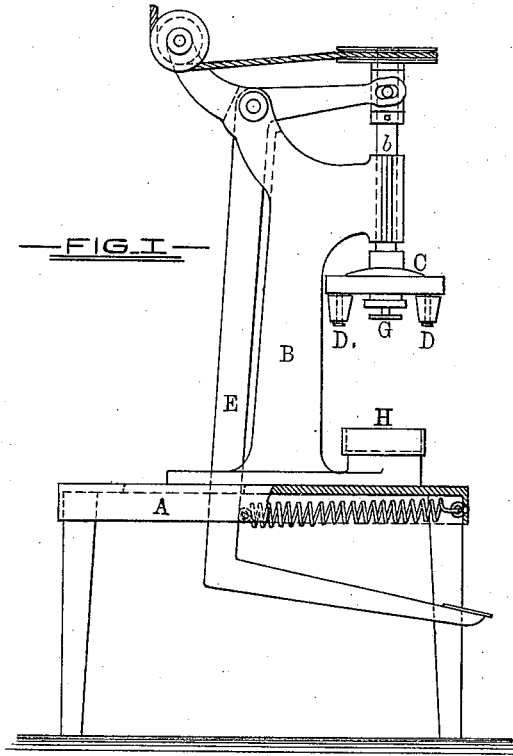

WITNESSES
Wm. W. Lawson
Frank M. Burnham

INVENTOR
William A. Wicks,
by G. H. W. Howard
Attor.

UNITED STATES PATENT OFFICE.

WILLIAM A. WICKS, OF BALTIMORE, MARYLAND.

IMPROVEMENT IN SHEET-METAL-CAN MACHINES.

Specification forming part of Letters Patent No. **197,440**, dated November 20, 1877; application filed July 12, 1877.

To all whom it may concern:

Be it known that I, WILLIAM A. WICKS, of the city of Baltimore and State of Maryland, have invented certain Improvements in Can-Machines, of which the following is a specification; and I do hereby declare that in the same is contained a full, clear, and exact description of my said invention, reference being had to the accompanying drawings, and to the letters of reference marked thereon.

This invention relates to certain improvements in a machine for closing the ends of the body of a sheet-metal can around the heads of the same, an operation preparatory to the permanent fastening of the said parts together by means of solder, as will hereinafter more fully appear.

This invention is intended to be used in the manufacture of that class of cans in which the bodies of the cans have outwardly-flaring ends to admit of the insertion of the heads to a limited distance only within the same, the said heads being provided with exterior flanges, which are soldered to the can-body from the outside thereof.

The said invention consists in providing a revoluble head, adapted to have a vertical sliding movement within bearings on a frame, with a series of independently-revoluble inverted conical projections on the under side thereof, the said conical projections being located at such distance from the center of the head as, in the revolution of the same, to effect the contraction of the flaring edge of the can-body around the can-head, when the same is brought into contact therewith.

The said invention further consists in combining, with the revoluble head aforesaid, a device for holding the can-head in position during the operation of the machine, as hereinafter described.

In the further description of my invention which follows, reference is made to the accompanying drawing, forming a part hereof, and in which—

Figure 1 is a partly-sectional side elevation of the machine, showing the revoluble head in an elevated position. Fig. 2 is a plan of the machine. Fig. 3 is a sectional view of a can and the revoluble head, in section, on an enlarged scale. Fig. 4 illustrates a modification

in the arrangement of the revoluble projection with reference to the revoluble head. Fig. 5 shows the projection as fixed to the head:

A is a table, and B a frame or stand extending upwardly therefrom. A portion of the stand is adapted as a bearing for the revoluble shaft *b*, to the lower end of which the head C is secured. D D are inverted conical projections attached to the under side of the head C, in such manner as to admit of their being revolved upon their axes and independently of the said head. A bent lever, E, is pivoted to the frame B, and is used as means for transmitting a downward movement to the shaft *b* and revoluble head C from the foot of the attendant. The upward motion of the said shaft and revoluble head is caused by a spring, which spring may be applied in any suitable manner. A presser-plate, G, provided with a spring, serves to hold the can-head tightly within the can-body during the operation of the machine, as hereinafter described.

A tray, H, on the table is used to hold the can while being operated upon, and its position with reference to the vertical center-line of the revoluble head is such as to center the can, or guide it to its proper place beneath the same.

The shaft *b* is shown in the drawing as driven through the medium of a belt; but any other means may be employed, if preferred.

In Fig. 4 the projections are revoluble and cylindrical in shape; but they are placed at an inclination with reference to the face of the head, and therefore are practically conical projections.

In Fig. 5 a similar design is shown, except that the projections are fixed to the head, and revolve with it, each projection performing one revolution upon its axis during a revolution of the head.

The operation of the machine is as follows: A can is placed upon the tray, and a head inserted in the upper end thereof. The attendant then places his foot upon the lower end of the bent lever, which is adapted as a treadle, and, by exerting a slight pressure thereon, causes the revoluble head to descend, and the conical projections thereon to be brought into contact with the flaring edge of the can-body. By continuing the downward movement of the revolu-

ble head, the flaring edge of the can-body, together with the flange of the can-head, are turned slightly inward, and a close joint formed between them. The revoluble head is now allowed to ascend, and the position of the can upon the tray reversed, after which the other head is secured in the manner described.

It will be understood that as it is only necessary to bring the upper edge of the can into contact with the conical projections on the revolving head to cause the contraction of the said edge around and upon the can-head, it is not material whether the can or the revolving head is subjected to the vertical movement necessary to bring them together; but the method herein shown is preferred.

Having thus described my invention, what I claim as new, and wish to secure by Letters Patent of the United States, is—

1. In a machine for contracting the ends of a can-body around or upon the can-head, a revoluble head, having inverted conical projections on the under side thereof, substantially as herein shown and described.

2. In combination with the revoluble head C, having the conical projections D on the under side thereof, the yielding presser-plate G, substantially as and for the purpose herein set forth.

In testimony whereof I have hereunto subscribed my name this 13th day of June, in the year of our Lord 1877.

WILLIAM A. WICKS.

Witnesses:

WM. T. HOWARD,
JNO. T. MADDOX, Jr.