

H. N. CARGILL.
Tunneling and Excavating Machines.

No. 197,456.

Patented Nov. 27, 1877.

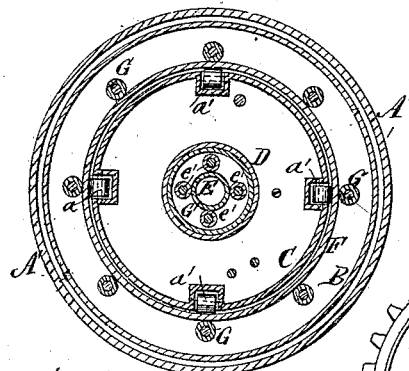
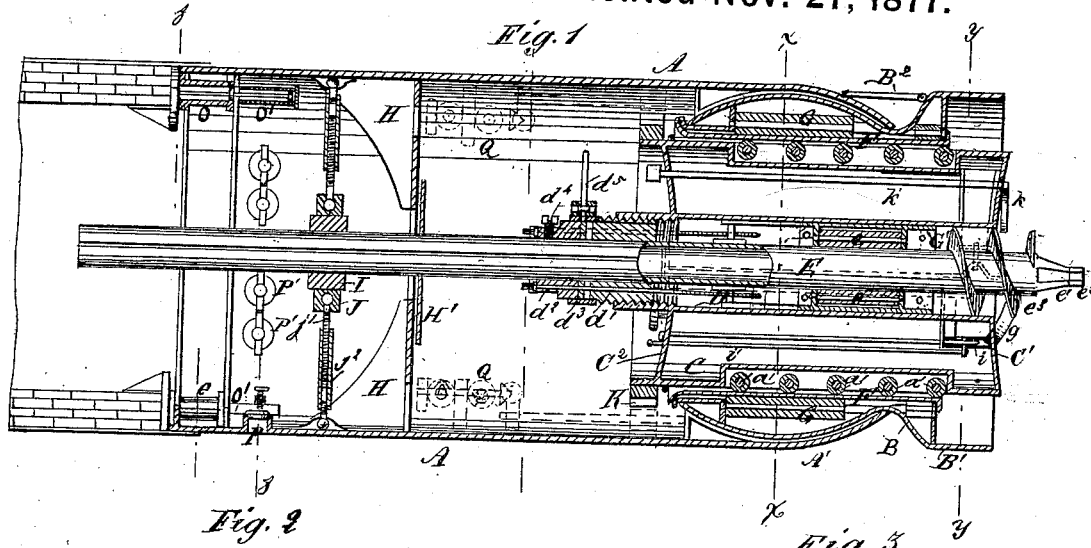

Fig. 4

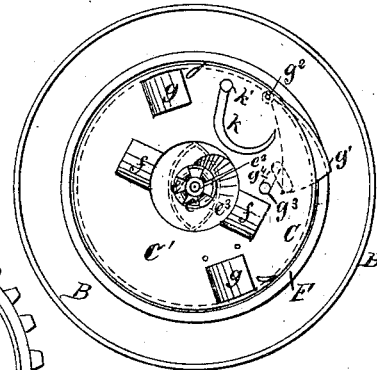

Fig. 5

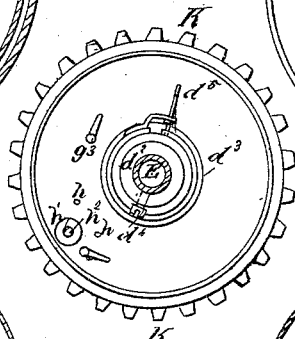

Fig. 6

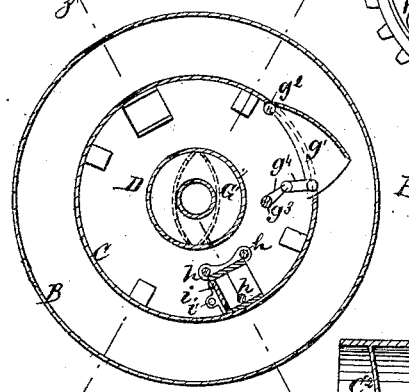
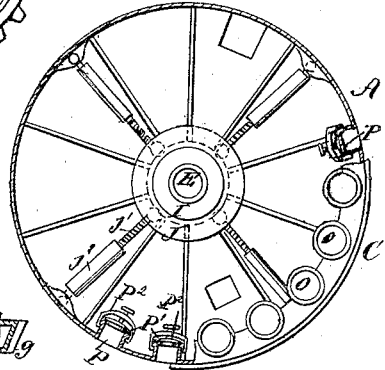

Fig. 7



WITNESSES:

C. Newell
Alex. J. Roberts

INVENTOR:

H. N. Cargill
BY *Mumford*
ATTORNEYS.

UNITED STATES PATENT OFFICE.

HAWLEY N. CARGILL, OF GRAND RAPIDS, MICHIGAN.

IMPROVEMENT IN TUNNELING AND EXCAVATING MACHINES.

Specification forming part of Letters Patent No. 197,456, dated November 27, 1877; application filed April 23, 1877.

To all whom it may concern:

Be it known that I, HAWLEY N. CARGILL, of Grand Rapids, in the county of Kent and State of Michigan, have invented a new and Improved Tunneling and Excavating Machine, of which the following is a specification:

Figure 1 is a longitudinal section of my improved excavator. Fig. 2 is a transverse section on line $x-x$ in Fig. 1. Fig. 3 is a front elevation. Fig. 4 is a detail view of the chain-wheel and rear end of the rotating drum. Fig. 5 is a transverse section on line $y-y$ in Fig. 1. Fig. 6 is a transverse section on line $z-z$ in Fig. 1. Fig. 7 is a longitudinal section of the rotating drum on line $z'-z'$ in Fig. 5.

Similar letters of reference indicate corresponding parts.

This invention consists of a cylindrical case or shield having a concave socket, to which the convex portion of another case is fitted, which carries the excavating mechanism. Within this last-mentioned case there are two concentric drums, the outer one of which rotates in contact with longitudinal rollers carried by the case, and the inner one rotates with the outer one, and is capable of sliding longitudinally therein, being guided and supported by friction-rollers. To the rear end of the said drum a chain-wheel is secured for receiving the driving-chain, and to its front end a series of cutters or excavators are attached. A shaft carrying an earth-auger is journaled in the center of the inner drum, and there are devices for operating and adjusting the various parts, as hereinafter more fully described.

Referring to the drawing, A is the main portion or body of the excavator, which consists of a hollow cylinder of iron, having formed at its front end a socket, A', for securing the globular portion of the casing B. The front end of the casing B is provided with a rim or flange, B', which is of the same diameter as the casing A. B² are plates hinged to the casing B for covering the joint between the casings A and B, and giving the exterior of the apparatus a cylindrical form throughout.

A number of rollers, G, having their axes parallel with the axis of the casing, are journaled in the said casing B, and form a bearing-surface for the hollow cylinder F, which

is placed in the casing B, and is retained by flanges at each end. Packing is used behind the forward flange of this drum to exclude water, sand, &c.

Within the cylinder F a cylinder, C, is placed, which is provided with four or more series of friction-rollers, a' , arranged in longitudinal rows upon transverse axes. The cylinder C is provided with heads C¹ C², which, in the present case, are concave; but they may be made of any other suitable form. In apertures in the center of these heads a tube, D, is secured, which projects rearward a short distance, and is threaded internally to receive a threaded guide, d' , for a tubular shaft, E.

A guide, G', consisting of a cylinder fitted to the said tube D, and containing longitudinal rollers e , forms an additional support for the shaft E, which support is capable of moving back and forth with, or independently of, the said shaft. Said cylinder is operated by screw-shafts, and, when forced into position, forms a water-tight joint in tube D and round shaft E. A perforated flange projects from the front of the guide G', for receiving a hook for withdrawing the said guide from the tube D. This flange forces the central column of earth outward to the excavator.

The front end of the shaft E is provided with a conical cutter, e' , which consists of three or more converging knives projecting from the end of the shaft and attached to a ring, e'' . A spiral auger-blade, e''' , is secured to the front end of the shaft E. This blade, together with the conical cutter e' , makes the central cut in the excavation, and acts as a screw-pile in drawing the cylinder C forward and holding it to its work. The shaft E operates as a main central guide to the machine as it advances.

The shaft E is slotted, and to it a collar, d'' , is fitted, which collar is provided with a friction-strap, d''' , that is operated by a lever, d'''' , so as to clamp or gripe the end of the guide d' , which is turned down to about the same diameter as the larger part of the collar d'' .

The guide d' and the threaded portion of the tube D are slotted to receive a key, which causes the guide d' to revolve with the said tube. A screw, d^4 , passes through the collar d'' , and into the slot of the shaft E. A key may be used with or without connection with this

screw. By contracting the friction-strap d^3 , the collar d^2 , and consequently the shaft E, is made to rotate.

Upon the rear end of the cylinder C a chain-wheel, K, is secured, which takes its motion, through a suitable chain, from engines arranged in the casing A. At the front end of the cylinder C there are three sets of excavators or cutters. One set consists of the cutters f , placed diametrically opposite, near the tube D, and are oppositely arranged with respect to each other, so that the rotation of the cylinder in either direction will cause one of them to cut. Another set consists of the cutters g , which are arranged diametrically opposite in the head of the cylinder, and are oppositely arranged with respect to each other, as in the case of the cutters f .

The cutters f g are curved from their cutting-edges backward to the head C^1 , for the purpose of throwing the earth and other material loosened by them, through apertures in the head C^1 , into the interior of the cylinder C, their cutting-edges overlapping the apertures in the cylinder. One of the cutters, g , is placed on guide-rods h , and may be thrust more or less through the head C^1 by turning a nut, h^1 , placed on the rod h^2 , which is attached to the cutter g . This cutter g is also provided with a sliding back piece, i , which may be moved from the rear end of the cylinder C by means of a rod, i' . Said back plate, together with the overlapping cutting-edge of the excavators, when closed, is for the purpose of forming a water-tight joint. The other cutters may be arranged to operate in the same manner.

The cutter g^1 is pivoted at g^2 to the cylinder C, and swings in a plane parallel to the plane of rotation of the said cylinder. This cutter is arranged so that when it is closed it will exclude water, and is capable of being moved outward to the rim B by turning a shaft, g^3 , which extends backward through the head C^2 of the cylinder C. One or more of these cutters may be used, which may be arranged to cut in either direction.

The shaft g^3 is provided with an arm, g^4 , which is connected to the cutter g^1 by means of a short connecting rod or link. A grapple-hook, k , is secured to a shaft, k' , that extends from the front to the rear of the cylinder. Said hook is designed for loosening and handling bowlders at the front of the excavating apparatus.

The rear end of the tubular shaft E is supported by a ring or sleeve, I, from which four or more screws, j , radiate, the said screws being provided with globular heads, which are fitted to corresponding sockets J in the ring I. The screws j^1 are fitted to internally-threaded sleeves j^2 , which are provided with ball-and-socket joints, the sockets of which are attached to the casing A. By turning the sleeves j^2 or the screws j^1 , the guide-screw shaft E, and consequently the casing B and the contained apparatus, may be directed at any angle (within certain limits) with the main portion A.

H is a bulk-head, stayed by suitable braces, and provided with a central aperture of sufficient size to permit any desired latitude of motion in the shaft E. H' is a plate that surrounds the shaft E, and covers the central aperture of the bulk-head, and is provided with a suitable packing, which makes a water or air tight joint around the shaft E and between the plate H' and the bulk-head H.

P P are apertures in the body A, through which piles may be driven when occasion requires. The said apertures are closed by valves or covers P^1 , which are secured by clamping-yokes P^2 .

O O are hydraulic cylinders, that are secured at equal distances around the interior of the rear end of the part A, and are connected with a single pipe, which supplies the water under pressure, so that the rams of all the cylinders may move simultaneously. Air-cylinders may be attached to the hydraulic cylinders O for working the rams back after they have been forced out.

The hydraulic cylinders are designed for forcing the excavating apparatus ahead after a quantity of earth has been removed in front of the apparatus. Their rams abut against the masonry, which is laid within the rearwardly-projecting edge of the part A.

The apparatus is to be driven by compressed air, and the engines (which are shown in dotted lines at Q) are to be arranged in any convenient position in the part A.

The interior of the cylinder C is to be provided with an internal spiral flange or screw, which will convey the earth cut by the apparatus to the rear end of the said cylinder, where it may be removed or discharged through doors provided for that purpose.

The operation of the machine is as follows: The chain-wheel K being connected with the driving-engines by means of a chain of suitable size and strength, the engines are set in motion, and the screw-blade e^2 is moved forward into the earth, either drawing the cylinder C with it or not, as may be desired. The screw e^3 is moved forward a sufficient distance to anchor it, so as to be capable of resisting the strain of drawing the drum C forward as it is rotated upon the screw d^1 , and thus fed up to its work.

It is obvious that to cause the tubular screw-shaft E to rotate it is necessary to insert a key in the slots of the tube D and the screw d^1 , and also to contract the friction-strap d^3 ; but when the cylinder C is moved forward, by turning upon the screw d^1 , this key must be removed.

The end cutters f g are operated first, and when they have cut as far as possible the cutter g^1 is thrown out gradually until the earth is removed from within the rim B.

Should any bowlders be encountered by the cutters e^1 , a drill may be inserted through the tubular shaft, and a hole made of sufficient depth to secure a cartridge of such size as to rend the bowlder, but not injure the machine.

After being broken up by the explosion of the cartridge, the fragments of the boulder will be thrust aside, to be removed by the cutters. The earth removed by the cutters is delivered to a spiral flange in the cylinder C, which, by its continual rotation, conveys it to the rear end of the said cylinder, when it may be removed or discharged through an opening made in the rear head of the cylinder for that purpose.

After a cut has been made within the range of the cylinder C, the entire apparatus is moved forward by the rams of the hydraulic cylinders, the cylinder C at the same time receding into the casing B. The operation of cutting is repeated, and at the same time an additional course of masonry is laid upon the rearwardly-projecting flange of the body A.

If piles are required to support the masonry, they may be driven through the openings P.

If there should be water in considerable quantities, so that it is impossible to remove it by pumps, the casing may be supplied with compressed air, and the water excluded and controlled by internal pressure.

Having thus described my invention, I claim as new and desire to secure by Letters Patent—

1. A casing, A, having a socket, A', in combination with a casing, B, having a globular portion, substantially as herein shown and described.

2. The hinged plates B², in combination with the casings A B, substantially as shown and described.

3. The combination of the casing B, having forward-projecting rim B¹, and longitudinal rollers G, with the cylinder F and sliding and revolving excavating-cylinder C, as and for the purpose set forth.

4. An excavating-cylinder, C, having concave front and rear heads, and a central tube, D, and provided with rollers a', in combination with the cylinder F and casing B, for guiding and supporting the excavators, substantially as set forth.

5. The combination of the excavators or cutters f g, arranged in opposite and reversed manner, with the cylinder C, as and for the purpose herein set forth.

6. The combination of the longitudinally-adjustable cutter g and screw h² with the excavating-cylinder C, as and for the purpose specified.

7. The movable back piece i, in combination with the cutter g, substantially as shown and described.

8. One or more laterally-swinging cutters, g¹, shaft g², having arms g⁴, and link for connecting it with the cutter g¹, and the cylinder C, in combination, substantially as herein shown and described.

9. The combination of the hook or grapple k and the shaft k' with the excavating-cylinder C, for removing stones or obstructions, arranged in advance of the excavators, as herein set forth.

10. The screw d¹, fitted to threads in the rear end of the tube D, and the guide G', containing rollers e, for guiding the tubular shaft E, substantially as shown and described.

11. The combination of the tubular guide and anchor shaft E, having cutters e¹ and spiral blade e², with the excavating-cylinder C, revolving upon said shaft, as and for the purpose set forth.

12. The combination of the collar d², having the screw d⁴, or its equivalents, the friction-strap d³, guide d¹, and shaft E, substantially as shown and described.

13. The combination of the solid bulk-head H and packing-plate H' with the stationary cylinder A, excavating-cylinder C, and guide and anchor shaft E, for forming an equilibrium of pressure against the excavating machinery, as herein set forth.

14. The combination of the ring I, sockets J, radial screws j¹, and internally-threaded sleeves j² with the cylinder A, and guide and anchor shaft E, and excavating-cylinder C, as and for the purpose set forth.

15. The combination of the hydraulic cylinders O, having attached air-cylinders O', with the casing A and excavating-cylinder C, as and for the purpose stated.

HAWLEY NATHAN CARGILL.

Witnesses:

L. BEMENT,

D. MCNAUGHTON.