

W. KROENER
Manufacture of Caps.

No. 197,478.

Patented Nov. 27, 1877.

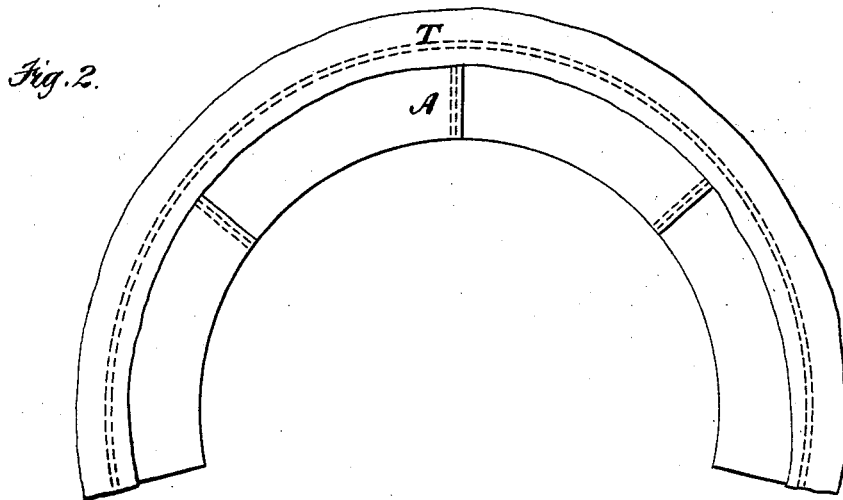
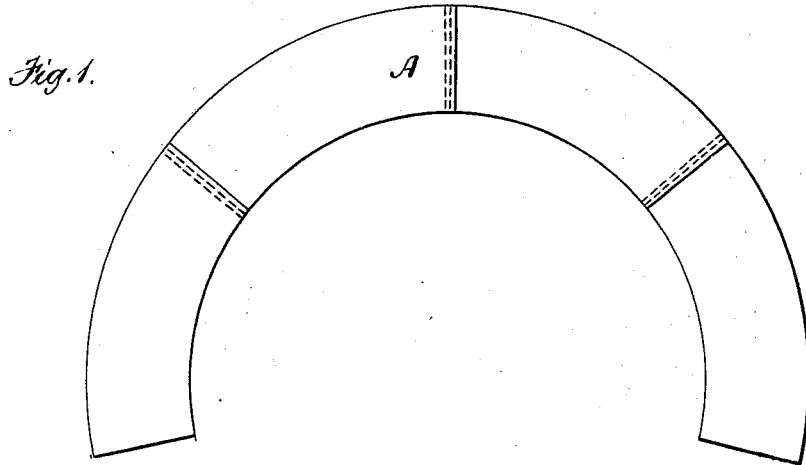
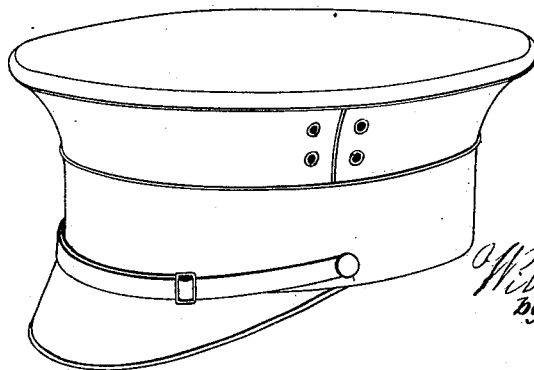

Fig. 3.



Witnesses.
Frederick Weis
John Johnson

Inventor
William Kroener
by his Attorney

UNITED STATES PATENT OFFICE.

WILLIAM KROENER, OF BOSTON, MASSACHUSETTS.

IMPROVEMENT IN THE MANUFACTURE OF CAPS.

Specification forming part of Letters Patent No. **197,478**, dated November 27, 1877; application filed September 20, 1877.

To all whom it may concern:

Be it known that I, WILLIAM KROENER, of Boston, Massachusetts, have invented an Improvement in the Manufacture of Caps, of which the following is a specification:

The object of my invention is to get, in such caps as are worn by the police, with large circular top and body or band slightly concave and diminishing in size as it recedes from the top, the peculiar shape of the same in a new way.

The present method in use requires the insertion of curved strips or springs of steel or whalebone to support the top. I claim to have produced by my invention a lighter, stronger, cheaper, and more durable cap.

Figure 1 represents the stiffening A, of varnished or stiffened horse-hair, cloth, or similar material, which is put inside the lining of the cap against the band, as hereinafter described. Fig. 2 represents the same stiffening A with a tape, T, sewed to it all around its upper edge on one side, leaving the tape overlapping the edge of the stiffening.

The top or cover of the cap, and the band or cloth covering of the cap which goes around it immediately under the top, having been turned

inside out and sewed together all the way round, the stiffening A is laid against the band, leaving the tape on the innermost side of the stiffening in contact with the common edge or edges, which have just been sewed together, of the top and band, to which common or double edge it is secured by stitches, which pass through it, but not through the stiffening A. The stitches pass through the tape T in that part where it overlaps the stiffening A, as close as possible to the edge of the stiffening. The whole thing being then turned right side out will be found to take naturally the requisite shape, and being strengthened by the rattan hoop used in such caps, which, in my cap, is put in loose into the part whose manufacture has just been described, to stretch the top and give it a firm edge, is then finished, lined, and blocked in the usual manner.

I claim as my invention—

The combination of the tape T and stiffening A with the top, band, and rattan hoop of the cap, substantially as described.

WILLIAM KROENER.

Witnesses:

JOHN JOHNSON,
FREDERICK WEIS.