

G. MEAD.

Disintegrating Apparatus for Reducing Grain, &c.

No. 197,484.

Patented Nov. 27, 1877.

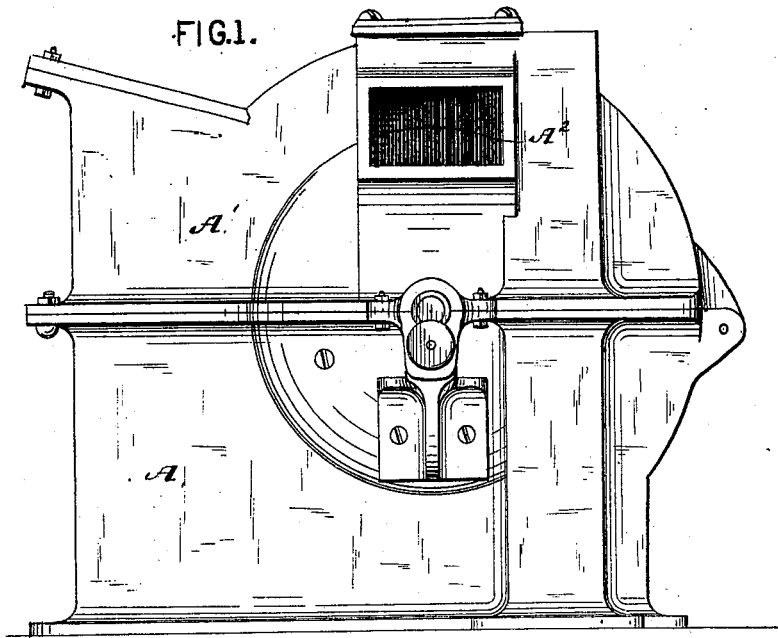
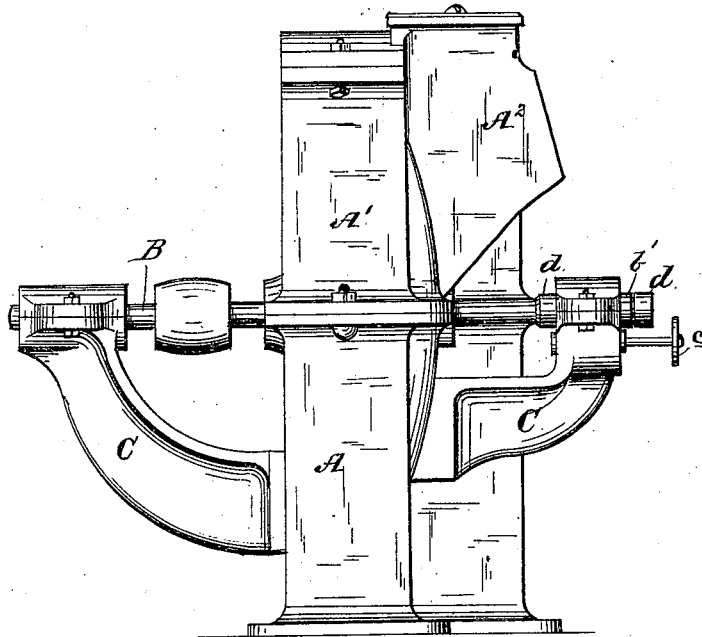

FIG. 2.



WITNESSES

R. T. Dyer
L. H. Dyer

INVENTOR

George Mead
by *Geo. W. Dyer & Co* ATTORNEYS

G. MEAD. Disintegrating Apparatus for Reducing Grain, &c.

No. 197,484.

Patented Nov. 27, 1877.

FIG. 3.

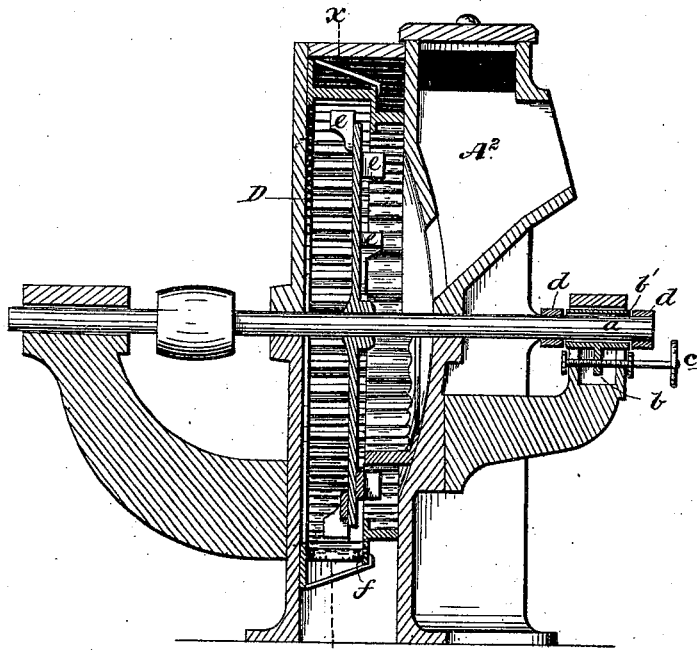
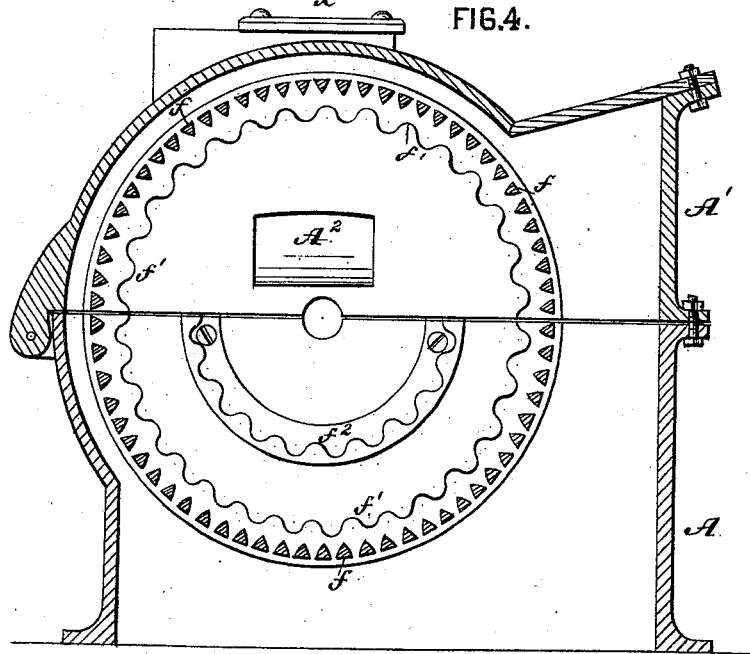

FIG. 4.



WITNESSES
R. T. Dyer.
S. H. Duly.

INVENTOR
George Mead
 by *Geo. W. Dyer & Co*
 ATTORNEYS.

UNITED STATES PATENT OFFICE.

GEORGE MEAD, OF DETROIT, MICHIGAN.

IMPROVEMENT IN DISINTEGRATING APPARATUS FOR REDUCING GRAIN, &c.

Specification forming part of Letters Patent No. **197,484**, dated November 27, 1877; application filed May 26, 1877.

To all whom it may concern:

Be it known that I, GEORGE MEAD, of Detroit, in the county of Wayne and State of Michigan, have invented a new and useful Improvement in Disintegrators; and I do declare that the following is a true and accurate description thereof, reference being had to the accompanying drawings, and to the letters of reference marked thereon, and being a part of this specification.

The nature of my invention relates to an improvement in mills for grinding or pulverizing corn and cereals, wherein their disintegration is effected by the impact of beaters on a revolving metallic disk, which, on breaking the grains, drive the particles into contact with a surrounding metallic grinding-surface.

The invention consists, mainly, in the peculiar grinding-surface, and in the combinations of the same with the peculiar disk, the hopper, and case; and, further, in the means for adjusting the shaft, as is more fully hereinafter set forth.

Figure 1 is a side elevation. Fig. 2 is an end elevation. Fig. 3 is a vertical cross-section on the line of the shaft; and Fig. 4, a longitudinal vertical section on the line $x x$ in Fig. 3, with the disk removed.

Like letters denote corresponding parts.

In the drawing, A represents the lower part or body of the case and frame, and A' the top, hinged thereto at one end. B is an arbor, provided with a driving-pulley, and is journaled in brackets C C, at either side of the machine. One of the journal-bearings, a , has a longitudinal movement in its bracket, through a temper-screw, c , tapped through a pendent lug, b , which hangs from a sleeve, b' , inclosing the shaft. A collar, d , on each side of the bearing a , carries the arbor with said bearing, the arbor being thus longitudinally adjustable. D is the grinding-disk, having two sets of L-shaped beaters, e , secured to one side or face, and one set to the other side or face, these latter at the periphery. The disk is inclosed by a screen, composed of triangular bars f , placed close together. On the feeding side a grinding-surface, f^1 , of like construction, but without intervals between the bars, is arranged. The outer row of beaters rotates inside of this grinding-surface.

f^2 is a similar grinding-surface, arranged at that side of the case, and in its lower half only, inside of which the innermost row of beaters rotates. A² is the hopper, which discharges the grain against the disk, rotating at a high velocity.

The inner row of beaters, striking the inflowing grains, throws them against the grinding-surface f^2 , breaking them in the operation. Falling off this surface, they are caught by the next row on the same side, and again dashed against the grinding-surface f^1 . They are carried entirely around this grinding-surface, and gradually fall over to the opposite side of the disk, when the particles are thrown against the screen f until they are reduced fine enough to pass between the bars of which it is composed. The discharge is around the entire periphery of the screen, but the meal naturally falls to the bottom.

By means of the screw adjustment hereinbefore referred to, the disk may be caused to approach the grinding-surfaces $f^1 f^2$. The nearer it is brought to them the longer the broken grain will be retained before passing to the screen, and vice versa.

The beaters heretofore used in machines of this class have been constructed of hard steel, tempered hard, in order to enable them to resist the enormous abrasion to which they were subjected, but which also rendered them very liable to break, owing to their extreme brittleness. These I make by piling together, alternately, hard and soft steel plates or laminæ, twisted and welded up, which construction combines the hardness to resist abrasive wear and toughness to prevent breakage.

What I claim as my invention is—

1. In a disintegrating-machine, the combination, with the case A A', of a single vertical grinding-disk, having lateral and peripheral beaters, a hopper for delivering the grain on one side of the disk, and the open and closed grinding-surfaces, substantially as and for the purposes set forth.

2. In a disintegrating-machine, the combination, with the vertical grinding-disk D, having lateral and peripheral beaters e , of the series of concentric closed and open grinding-surfaces, whereby the grain is first broken upon the closed or solid surfaces, and drops by

gravity onto the open surface, through which it is driven by the beaters, constructed and arranged substantially as described and shown.

3. In a disintegrating-machine, the series of open and closed concentric grinding-surfaces f f^1 f^2 , constructed and arranged substantially as described and shown.

4. In a disintegrating-machine, the combination, with the single vertical disk D , provided with lateral and peripheral beaters e , and adapted to be adjusted horizontally, of the open and closed concentric grinding-surfaces f f^1 f^2 , over and between which the beaters pass,

constructed and arranged substantially as described and shown.

5. In a disintegrating-machine, the combination, with the shaft a , of the collars d , fixed on such shaft on each side of the bearing, the sleeve b' , having lug b , and the screw c , constructed and arranged substantially as described and shown.

GEORGE MEAD.

Witnesses:

CHARLES J. HUNT,
C. R. HULETT.