

J. A. TURNER & J. T. STONEHAM.
Apparatus for the Manufacture of Paper for Packing
Goods, &c.

No. 197,502.

Fig. 7. Patented Nov. 27, 1877.

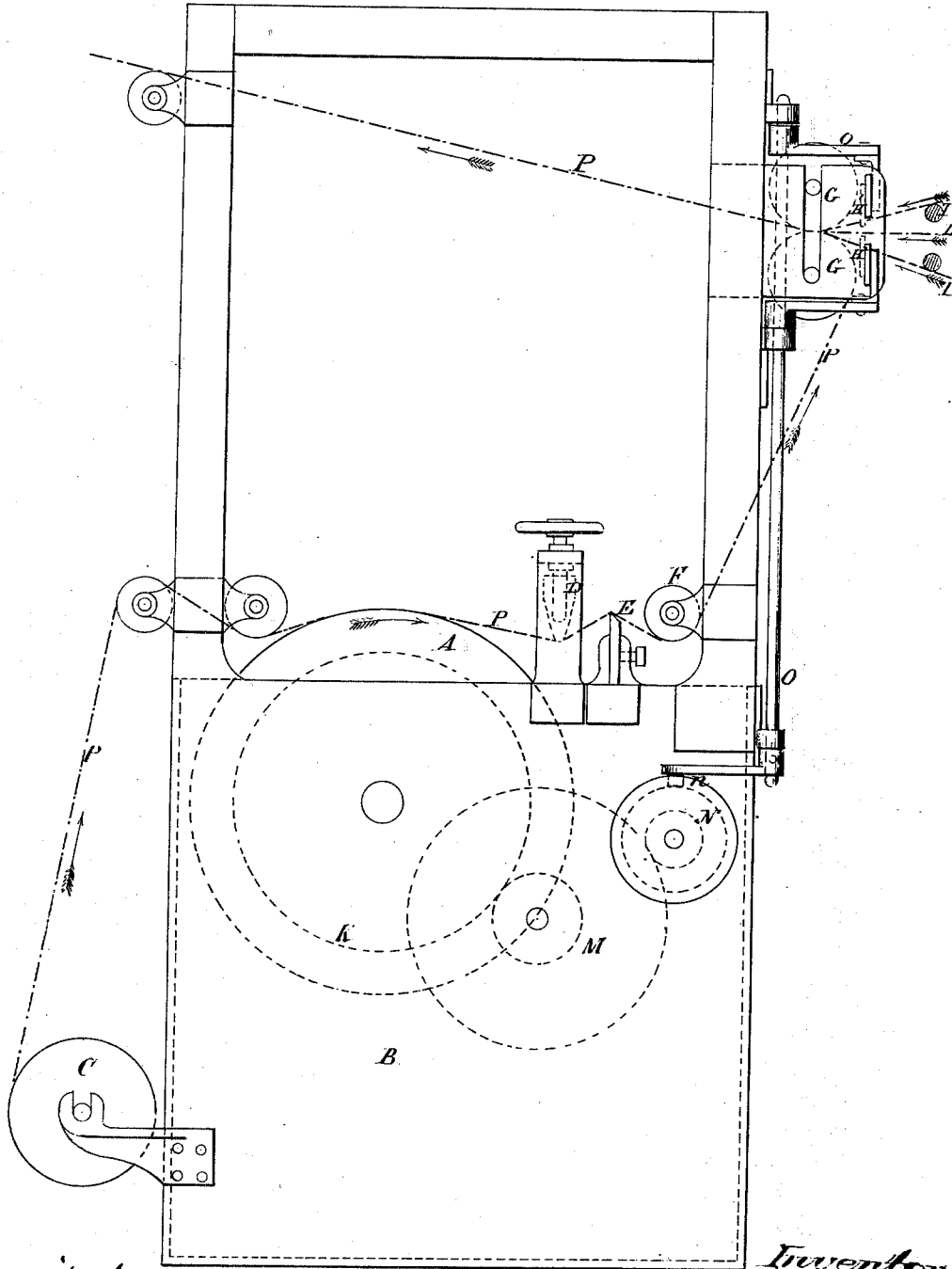

Witnesses
H. S. Boshick.
E. J. Martin

Inventors
J. A. Turner
J. T. Stoneham by
C. S. Whitman atty

J. A. TURNER & J. T. STONEHAM.
Apparatus for the Manufacture of Paper for Packing
Goods, &c.

No. 197,502.

Patented Nov. 27, 1877.

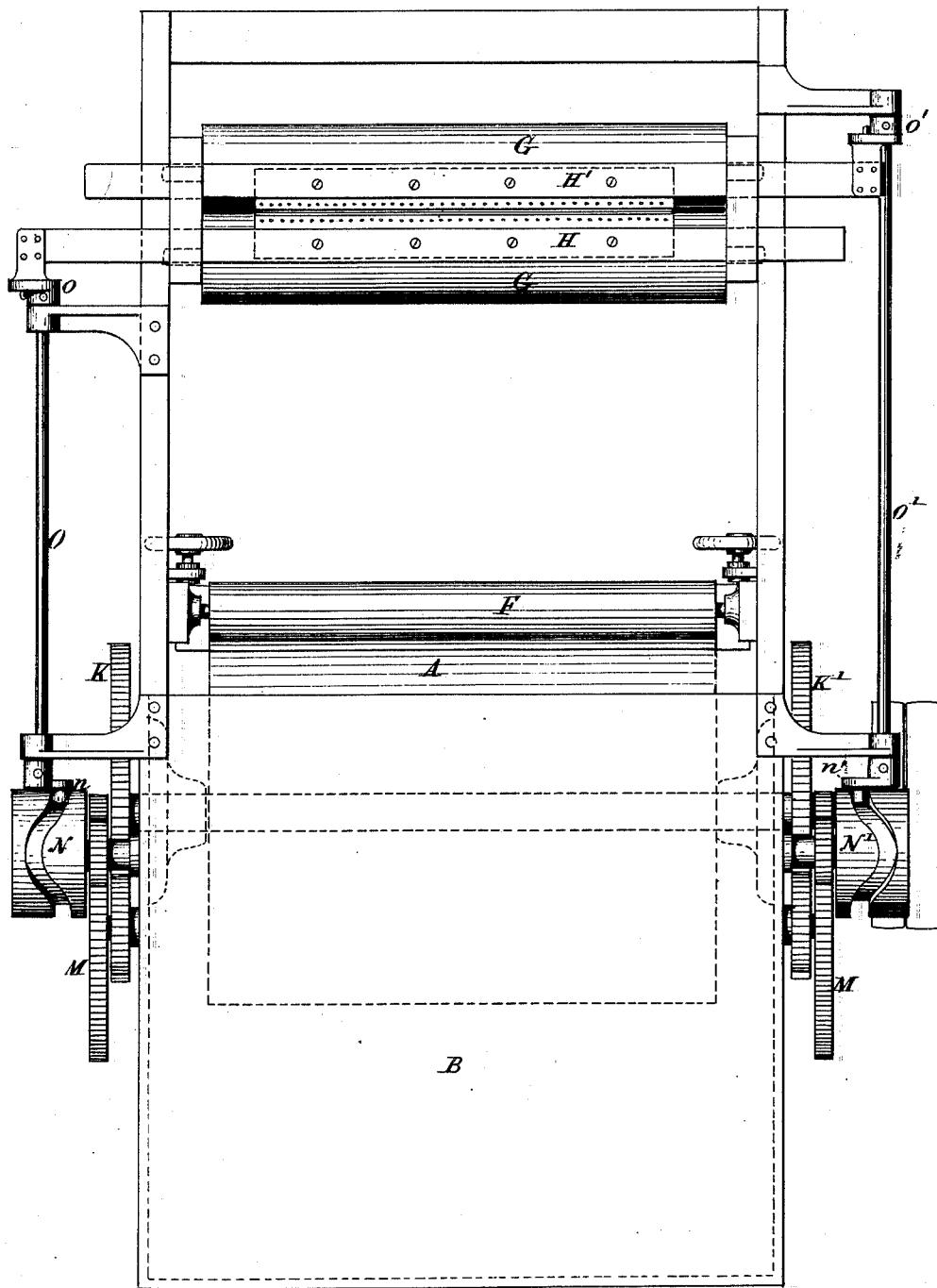

*H. D. Bostick witness
E. J. Martin*

*J. A. Turner Inventor
J. T. Stoneham by
C. S. Whitman
attorney*

J. A. TURNER & J. T. STONEHAM.
Apparatus for the Manufacture of Paper for Packing
Goods, &c.

No. 197,502.

Patented Nov. 27, 1877.

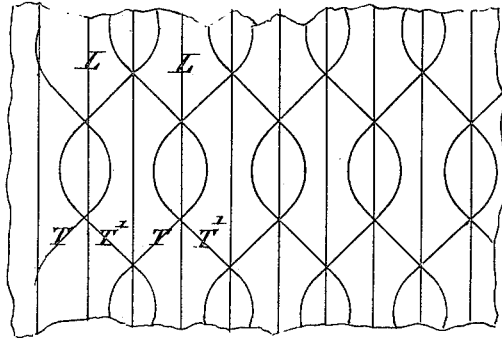

Fig. 4.

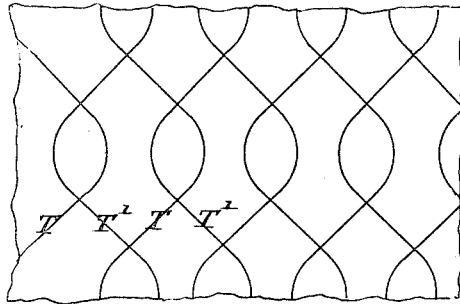
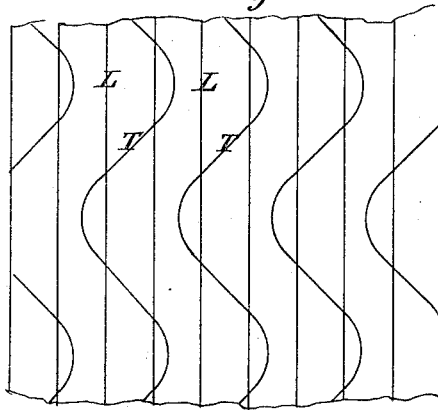

Fig. 5.



Witnesses
T. L. Boshier
E. S. Martin

Inventor
J. A. Turner
J. T. Stoneham by
C. S. Whitman atty

UNITED STATES PATENT OFFICE.

JAMES A. TURNER AND JAMES T. STONEHAM, OF WEST GORTON, ENGLAND;
SAID STONEHAM ASSIGNOR TO SAID TURNER.

IMPROVEMENT IN APPARATUS FOR THE MANUFACTURE OF PAPER FOR PACKING GOODS, &c.

Specification forming part of Letters Patent No. 197,502, dated November 27, 1877; application filed December 18, 1875; patented in England, May 5, 1875.

To all whom it may concern:

Be it known that we, JAMES ALFRED TURNER and JAMES TOLPUTT STONEHAM, both of West Gorton, in the county of Lancaster, England, manufacturers, have invented an improved material for covering or packing goods, and a process and apparatus for manufacturing the same; and do hereby declare that the following description, taken in connection with the accompanying sheets of drawings, hereinafter referred to, forms a full and exact specification of the same, wherein we have set forth the nature and principles of our said improvement, by which our invention may be distinguished from others of a similar class, together with such parts as we claim and desire to secure by Letters Patent—that is to say:

Our invention relates to the manufacture of a material suitable for covering or packing articles, for lining packing-cases, and other purposes.

Fabrics for these purposes have hitherto been produced by uniting together with water-proof material two or more thicknesses of paper or woven fabric, or a thickness of paper with a thickness of woven fabric, and, in some cases, by the use of a single thickness of paper strengthened in one direction with parallel threads.

The object of our invention is to produce at a cheap rate a material or fabric which is strengthened in both directions without the use of fabric previously woven, which we effect in the following manner: We cause a continuous web of paper to travel in the direction of its length, serving it or covering it with water-proof or water-repelling material in a fluid or semi-fluid condition—as, for example, drying-oil, resinous or bituminous material, caoutchouc, gutta-percha, and the like. From a beam or set of bobbins we supply a number of threads, which are laid or passed over and on the served paper longitudinally; and from other bobbins we supply other threads, which, by means of oscillating levers or bars, have a transverse movement imparted to them while the paper travels onward, by which means these threads are laid in a diagonal or zigzag manner over and onto the paper and longitu-

dinal threads. The whole then passes between rollers, which press the paper and threads firmly together, the water-proof or water-repelling material causing the whole to cohere.

Sometimes we employ fine wires instead of or along with the threads, either the longitudinal or the transverse, or both; and sometimes, also, we pass another thickness of paper through the pressing-rolls, so as to cover the threads or wires.

For this process of manufacture we employ apparatus of which Figure 1 of the accompanying drawings represents an end view, and Fig. 2 a front view. Figs. 3, 4, and 5 represent several different patterns of material that may be manufactured, as we will now describe.

A is a roller, which is made to revolve in the direction of the arrow in a tank or vessel B, containing the water-proof or water-repelling adhesive material in a fluid or semi-fluid condition. When the material employed is of a kind that is rendered fluid by heat, the tank B is kept hot by a steam-jacket, and A is made as a steam-roller. A continuous web of paper, P, is drawn from a beam, C, passed over the roller A, under a deflecting-rule, D, and over a knife or scraper, E, so that it receives a coating of the adhesive material from the roller A, and has this coating scraped and equalized by the knife E. The paper then passes round a guide-roller, F, and between two pressing-rollers, G G, whence it is led to drying rollers, which, being of the ordinary construction, are not shown in the figures. A number of longitudinal yarns, L, derived from a beam or from bobbins, pass with the paper between the rollers G G. Also, a number of other yarns, T T', are passed through holes in plates H H', which are caused, by means which we will presently describe, to reciprocate rapidly to and fro across the paper, and these yarns T T' pass also between the rollers G G along with the paper. The plates H H', reciprocating transversely while the paper travels onward, have the effect of laying each of the yarns T T' upon the paper in a zigzag form, and by arranging the motions of the two plates H and H' so as to make their strokes in opposite directions, the yarns T of the one set are made to cross those of the other set, T', so that when the two sets

are laid on the paper they appear arranged as a net-work in the form of a number of successive diamonds.

The plates H H' are caused to reciprocate in the following manner: On the axis of the roller A we fix a toothed wheel, K, which, by an intermediate wheel and pinion, M, drives a roller, N, having an undulating cam-path cut in its periphery. In this cam-path is inserted an anti-friction roller, *n*, mounted on an arm projecting from a vertical spindle, O. Another arm, *o*, on this spindle, is jointed to one of the plates H.

A like arrangement of gearing, with a cam-roller and upright spindle at the opposite side of the machine, is provided to work the other plate, H', and, both plates being fitted to slide horizontally in guides, their reciprocation is effected by the action of the cam-paths N N', causing the spindles O O' to rock. The cams N are so set that the plates H H' are made to reciprocate always in opposite directions.

The intermediate gearing M, by which the roller A is connected to the cams N, may be made in any desired proportions; and several sets of such gearing, in different proportions, may be provided, like the change-wheels of a lathe, so that the velocity of the cams in relation to that of the roller A may be varied. In this manner the obliquity of the yarns T T', as they are laid on the paper, may be altered at pleasure.

In some cases we dispense entirely with the longitudinal yarns L, or employ only a few of these at or near each edge of the paper to form a selvage, strengthening the edges. Also, we sometimes employ only one set of the transverse yarns T T', and in such a case one of the plates H H', being kept stationary, can serve to guide longitudinal yarns, if desired.

Fig. 3 represents a portion of the material thus manufactured, having the longitudinal yarns L, and also the two sets of transverse zigzag yarns T and T'.

In the pattern shown in Fig. 4 the longitudinal yarns are omitted, and in the pattern Fig. 5 the longitudinal yarns L are crossed by only one set, T, of the zigzag yarns. Both the zigzag yarns T T' and also the longitudinal yarns L, when these are employed, in passing with the coated paper between the rollers G G, are caused to adhere to it, strengthening it longitudinally and transversely, so

that when the adhesive material dries or sets the whole forms a water-proof paper, strengthened, as with a woven fabric, the preliminary weaving of the latter being dispensed with.

Sometimes we lead from another beam or roller a web of thin paper onto the paper P at a point beyond the rollers G G, passing both between pressing-rollers, so that the thin paper is caused to adhere to the main web P and to cover the yarns laid upon it, forming a lining to the material.

The yarns L and T T' may be threads of any suitable material; or fine wires may be used when great strength and stiffness are desired.

Having thus described the nature of our invention, and the best means we know of carrying it into practical effect, we hereby declare that we make no general claim to a material for covering or packing goods, consisting of one or more thicknesses of paper served with adhesive water-proof or water-repelling material, and strengthened by parallel warp-yarns, or by fabric previously woven; but

We claim—

1. The described apparatus for manufacturing the said material by causing a web of paper served with adhesive material to travel longitudinally, while one or two sets of yarns, threads, or wires are guided by oscillating bars to traverse to and fro across the paper, consisting of the rollers G G, the plates H H', the vertical spindle O, having an arm, upon which an anti-friction roller, *n*, is mounted, and the roller N, having an undulating cam-path cut in its periphery.

2. In apparatus for the manufacture of the said material, the oscillating bars H H', provided with holes, through which yarns T T' are passed, for guiding the yarns, threads, or wires, so that they are laid in zigzag form on the traveling paper, constructed and operating substantially as herein described.

3. The combination of the roller A, tank B, beam C, deflecting-rule D, scraper E, guide-roller F, and pressing-rollers G G.

In testimony whereof we have signed our names to this specification in the presence of two subscribing witnesses this 22d day of October, 1875.

JAMES ALFRED TURNER.
JAMES TOLPUTT STONEHAM.

Witnesses:

JOSHUA ALFRED ELLIOTT,
EDWIN ALMOND.