

M. L. UTTER.
Cultivator.

No. 197,503.

Patented Nov. 27, 1877.

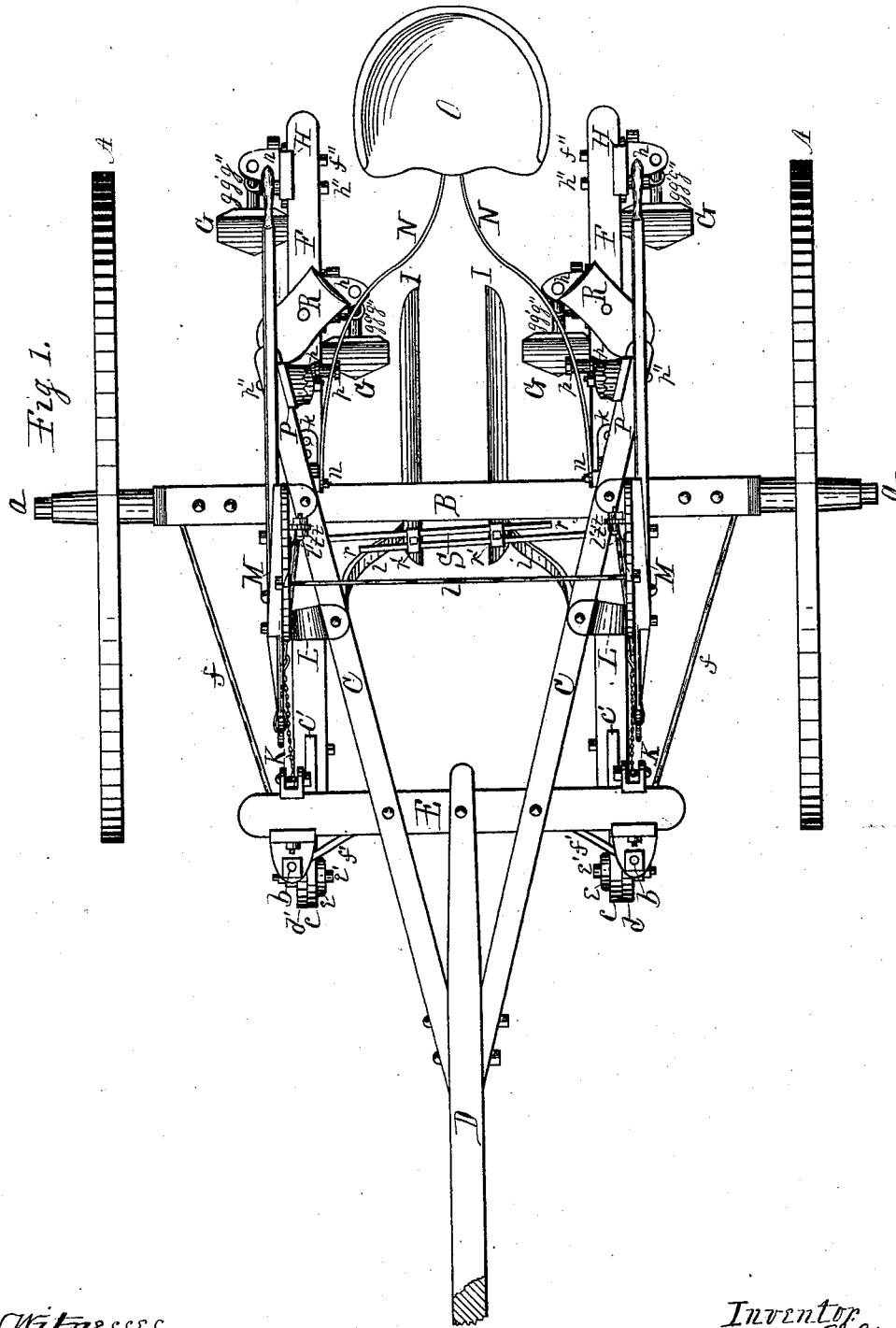

Witnesses
J. M. Doubler
A. C. Bohel

Inventor
Morris L. Utter
Per Jacob Behel
Atty

M. L. UTTER.
Cultivator.

No. 197,503.

Patented Nov. 27, 1877.

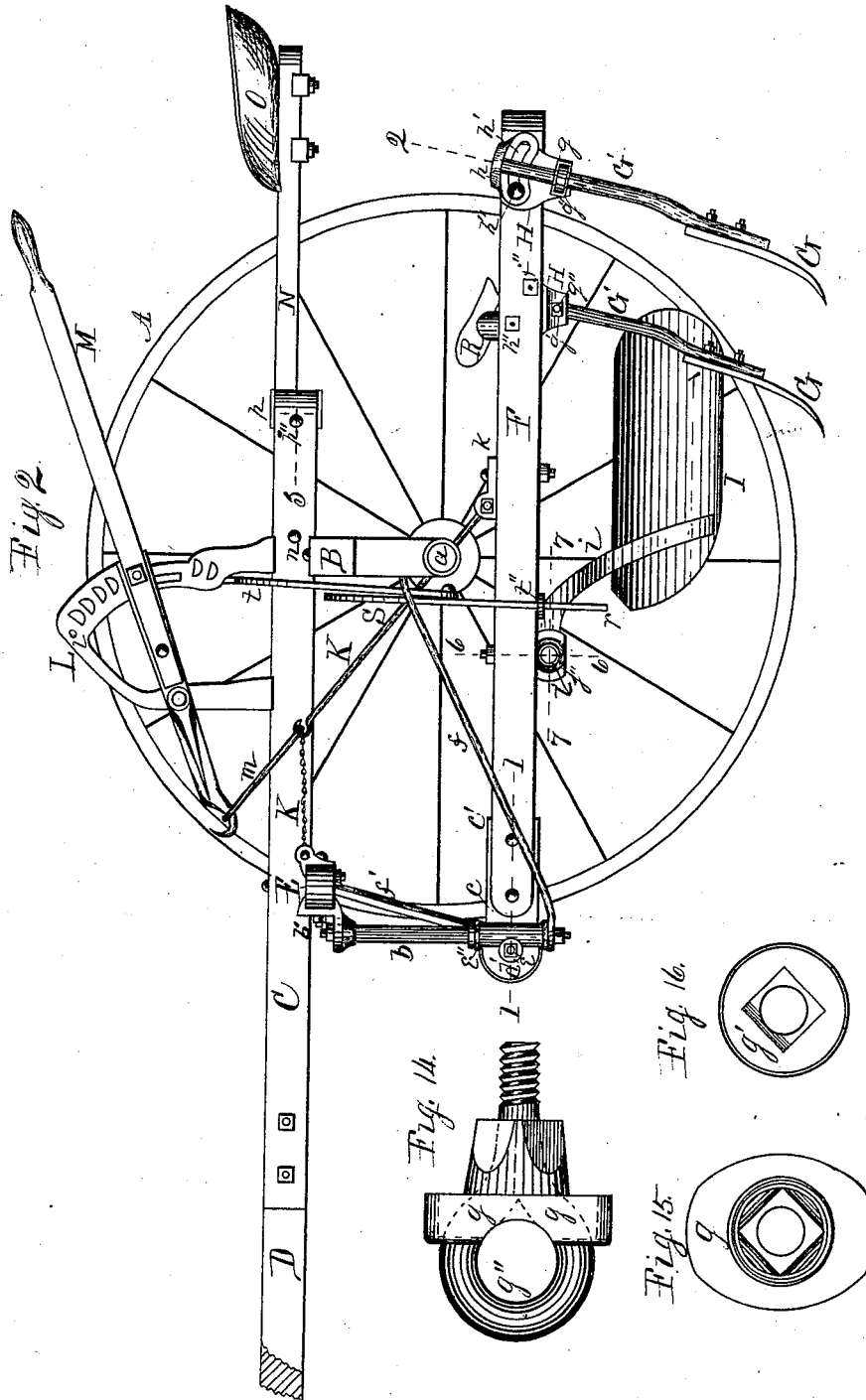

Witnesses:
W. H. Baubler
A. O. Bohel.

Inventor:
Morris L. Utter.
Per Jacob Behel
Atty.

M. L. UTTER.
Cultivator.

No. 197,503.

Patented Nov. 27, 1877.

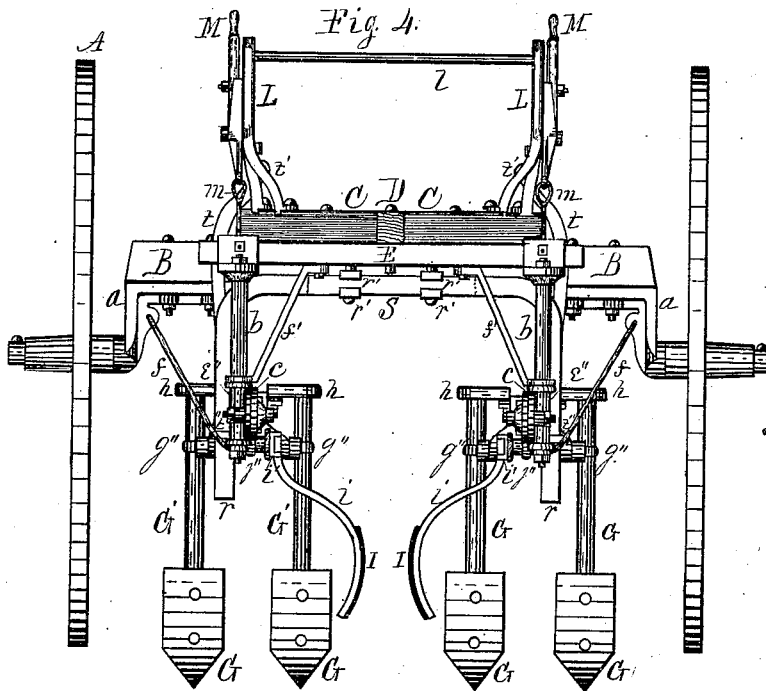
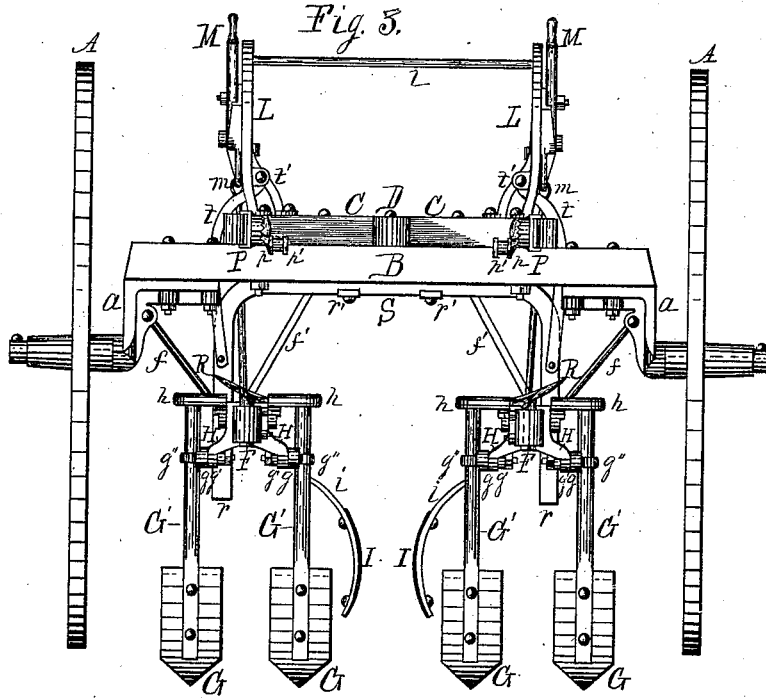

Witnesses.
J. H. Daubler
A. O. Behel

Inventor.
Morris L. Utter.
Per. Jacob Behel
Atty.

M. L. UTTER.
Cultivator.

No. 197,503.

Patented Nov. 27, 1877.

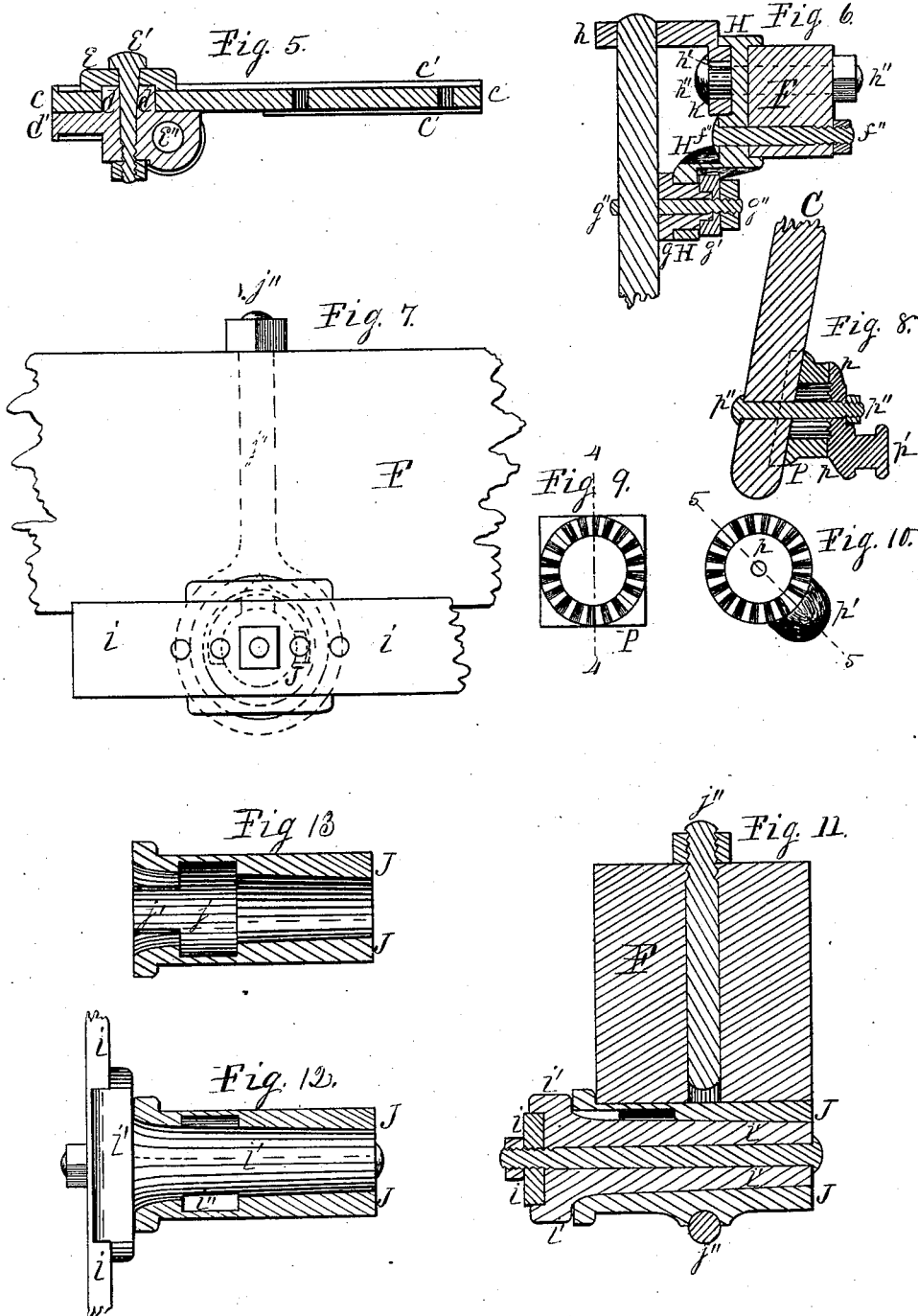

Witnesses.
J. M. Daubler
A. O. Bohel

Inventor
Morris L. Utter
Per Jacob Behel
Atty.

UNITED STATES PATENT OFFICE.

MORRIS L. UTTER, OF ROCKFORD, ILLINOIS.

IMPROVEMENT IN CULTIVATORS.

Specification forming part of Letters Patent No. 197,503, dated November 27, 1877; application filed August 14, 1877.

To all whom it may concern:

Be it known that I, MORRIS L. UTTER, of the city of Rockford, in the county of Winnebago and State of Illinois, have invented a new and useful Improvement in Cultivators, which improvement is fully set forth in the following specification and accompanying drawings, in which—

Figure 1 is a plan view of a cultivator embodying my invention. Fig. 2 is a side elevation, with the rear wheel omitted to show the remaining parts more clearly. Fig. 3 is a rear elevation, and Fig. 4 is a front elevation, in both of which the driver's seat is omitted. Fig. 5 is a transverse horizontal section of the front joint of drag-bars on dotted line 1. Fig. 6 is a transverse section of the shovel-standard bracket on dotted line 2. Fig. 7 is an inside elevation of a portion of the drag-bar and shield attachment. Fig. 8 is a horizontal section of the adjustable support for the driver's seat on dotted lines 3, 4, and 5. Figs. 9 and 10 are views of the rosette-faces of the adjustable support for the driver's seat. Fig. 11 is a vertical transverse section on dotted line 6 through the shield-support. Fig. 12 is a plan view of the shield-support, in which the adjustable socket is shown in section on dotted line 7. Fig. 13 is the upper half of the adjustable socket, removed. Fig. 14 shows the swivel-socket of shovel-standard bracket, with eyebolt in place. Fig. 15 is a view of the socket end of the swivel-socket, and Fig. 16 is a face view of the socket-washer.

This invention relates to that class of machines known as sulky or straddle-row cultivators; and consists in the construction and arrangements of the parts and of the devices employed to produce an effective machine for the cultivation of crops planted in rows or drills, which will be hereinafter more fully described.

In the figures, A represents carrying-wheels fitted to revolve on crank-formed axle-arms *a*, secured to the axle-tree B. Two converging beams, C, secured toward their rear ends to the axle-tree, are connected at their forward ends to beam D. These beams are connected rearward of their junctional point, and about on a line with the front of the carrying-wheels, by a transverse bar, E, secured to their un-

der sides, which forms the tongue of the machine, having an opening between the beams C, forward of the axle-tree. The beams C extend rearward of the axle-tree, for a purpose hereinafter explained.

Pendent bars *b* are connected by brackets *b'* to the outer ends of the transverse bar E, having their lower ends made in journal form. F are drag-bars, having their forward ends slotted, and fitted with a joint-plate, *c*, provided with flanges *c'* on their edges to embrace the opposite sides of the bars, and are held in place by screw-bolts passed through the beam and plate. The forward ends of these joint-plates are fitted to receive the studs *d*, which project from the inner face of the joint-plates *d'*.

The washers *e* are fitted to receive the ends of the studs, which project through the plates *c*. A screw-bolt, *e'*, in the axis of this joint, passes through the washer *e* and studs *d*, to receive the screw-nut on the outside of the plate *d'*, which holds the parts in place in such manner as to permit the joint-plates *c* to turn freely on the studs *d*.

The joint-plates *d'* are provided on their outside with a vertical socket, *e''*, which receives the journal-formed lower ends of the pendent bars. This joint is clearly shown, in section, in Fig. 5, and is made capable of use on both sides of the machine, to connect the drag-bars thereto, in such manner that their rear ends will be free to vibrate vertically and laterally independent of each other, and to prevent axial or rolling motion in the drag-bars.

Brace-rods *f*, secured to the lower ends of the pendent bars and to the axle-arms, in connection with brace-rods *f'*, connected to the lower ends of the pendent bars and to the cross-bar E, give firmness to the frame and support to the pendent bars to resist the draft-strain.

Cultivator-shovels of the usual form, made from suitable material, are represented at G, and are fixed to round standards G' by rivets or screw-bolts.

H represents the bed-plate of a bracket employed to hold the shovel-standards, with the shovels thereto attached in position on the drag-bars. One of these bed-plates is placed on the outside and rear end of each drag-bar,

and one on the inside of each, in advance of those on the outside, and are held in place thereon by screw-bolts f'' , which pass through the plates and through the drag-bars, which fix them firmly in place. The lower or pendent ends of these bed-plates are provided with an opening to receive the swivel-socket g , having its end, which projects through the plate, made square to receive the socket-washer g' .

An eyebolt, g'' , fitted to receive the shovel-standard is passed through the swivel-socket and socket-washer, and by means of its screw-nut the shovel is held to the socket in such manner that when the shovel swings back the swivel-socket will turn in the bracket, carrying with it the several parts that hold the shovel to the bracket, without either tightening or loosening the screw-nut on the eyebolt, when placed on either the right or left hand sides of the drag-bars. These eyebolts permit the shovels to be set to throw the earth to either side, to or from the plants, and to adjust them vertically to control their relative working depth.

Slip-arms h , fitted to receive the upper end of the shovel-standards, are provided with a base-plate, slotted as at h' , and made adjustable back and forth in the direction of the length of the drag-bar, for the purpose of changing the pitch of the shovels, so as to incline them more or less relatively with the drag-bar. These slip-arms are held in contact with bed-plates H by a screw-bolt, h'' , passing through the slot, bed-plate, and drag-bar, which hold the standards in their adjusted position sufficiently rigid for the purpose of cultivation, and when they come in contact with any substance offering greater resistance than the parts would bear with safety, the slot h' will permit the arm to slide forward, permitting the shovel to swing back to pass or ride over obstructions without breaking; and when the obstruction is passed the shovel can be readjusted. The force required to cause the parts to slip can be regulated by means of the screw-bolt h'' . These brackets are made reversible, and capable of use on either side of the drag-bars.

I are shields, made in proper form, from plate material, and to their forward portions are riveted supporting-arms i , which curve upward, outward, and forward to meet the inner face of the drag-bars. The forward ends of these supporting-arms are secured to the swivel-block i' , provided with a stop, i'' , projecting from its side. This swivel-block i' is fitted to enter the tubular socket J , provided for its reception, fitted with a chamber, j , having a slotted opening, j' , on its upper side to admit the stop i'' on the swivel-block to the chamber j .

The annular length of the chamber j is such as to limit the oscillatory movement of the swivel-block in the socket to about half a revolution. These chambered sockets are secured to the under sides of the drag-bars, forward of their centers, by an eyebolt, j'' , which

receives the socket, and is passed up through the drag-bars, and held in place by a sufficient screw-nut.

From the above it will be seen that the chambered sockets may be turned in the eyebolt, so as to limit the downward movement of the shields, and that they will be free to rise to pass over inequalities in the surface.

By raising the shields until the stop i'' comes opposite the slotted opening j' , they may be removed or replaced when required.

The object of this part of my invention is to provide a shield to protect the plants in cultivation from clods, earth, or other substance thrown by the shovels, and that can be readily adjusted, removed, and applied, as circumstances may require.

K are supporting-chains or linked rods, connected at their forward ends to the cross-bar E , slightly in rear of the pendent bars, on which the forward ends of the drag-bars are hinged, and in the same lengthwise vertical plane. The rear ends of the supporting-chains are connected to plates k , which are connected to the drag-bars about midway of their length, and are made adjustable lengthwise thereon, to control the extreme depth of cultivation.

From the foregoing, and by reference to the drawings, it will be seen that the pivotal points on which the drag-bars swing are so nearly in a vertical line that their limited lateral movements in cultivating will, for all practical purposes, be substantially in a horizontal plane.

L are segment-ratchets, of the form represented in the drawings, secured to the beams C . A transverse rod, l , connects the upper ends of these ratchets to combine their strength. Lifting and supporting levers M are pivoted to the forward legs of the ratchets, and are provided with a detent to engage the teeth therein, and are also provided with a spring, U , on their inner sides, the free ends of which operate against the side of the ratchets to hold the levers in contact therewith, from which they are relieved by pressing their handle ends outward. The forward ends of these lifting and supporting levers are connected to the supporting-chains by a link, m . These levers, with their chain-connections, furnish the means for raising and lowering the drag-bars and the shovels thereto attached, and, in connection with the detents and ratchets, serve to adjust and control their working depth and to hold them suspended for transportation.

The seat-frame is composed of curved bars N , secured at their forward ends to the beams C , near the axle-tree, on pivot-bolts n .

O is the driver's seat, secured on the rear end of the seat-frame, and made lengthwise adjustable thereon, to accommodate the operators and to balance the machine.

P are rosette-plates, provided with flanges to receive the beams C , and p are corresponding rosette-plates, from the inner face of which project studs p' eccentric to the plate. The

contiguous faces of these rosette-plates are corrugated to match, and are made adjustable to change the position of the stud p' with relation to the plate P. These plates are secured to the rear ends and inner faces of the beams C by screw-bolts p'' , which pass through the plates and beams, the inner plates being adjustable to raise or lower the inward-projecting studs p' , on which the seat-bars are supported for the purpose of raising and lowering the seat to accommodate the operator.

R are foot-supports secured to the drag-bars, to receive the feet of the operator, for the purpose of moving the drag-bars and the shovels thereto attached laterally to conform to the sinuosities of the rows of plants, and to pass plants out of line.

S represents a sway-bar composed of two similar halves, consisting of bars r bent at right angles, forming two legs of about equal lengths, placed so that their crowning portions lap each other, and form three sides of a rectangle, and are held in position relatively by clasp-plates r' placed on the upper and under sides of the crowning portion, where the parts lap, and hold them in position laterally adjustable by screw-clamping bolts passing upward through the clasp-plates and between the overlapping bars. This sway-bar is suspended in front of the axle-tree on links t , pivoted at their lower ends to the depending legs of the sway-bar, and at their upper ends to studs t' projecting from the rear legs of the ratchets inward, to permit the sway-bar to swing laterally.

The depending ends of the sway-bar are received loosely in guide-sockets t'' fixed to the drag-bars, which hold them in such manner that their relative lateral movements shall be in unison and vertically independent.

By means of the clasp-plates r' and clamping-bolts the depending legs of the sway-bar are made adjustable closer to or farther from each other, to increase or lessen the distance between the drag-bars to cultivate closer to or farther from the plants.

I claim as my invention—

1. The combination, with the axle-tree, the converging beams C, secured thereto, and cross-bar E, of the pendent bars b , secured to the ends of cross-bar E by brackets, and the brace-rods f and f' , the brace-rod f being secured to the pendent arm and arm of the axle, while the brace connects the lower end of the pendent arm with the cross-bars, substantially as described.

2. The joint-plates c and d , washer e , and joint-bolt e' , these parts constructed, arranged, and operating, as herein described, to produce a double hinge-joint, reversible and interchangeable, capable of use on either side of the machine, as and for the purpose hereinbefore set forth.

3. The combination, with the levers M, located in front of the driver's seat, of the supporting-chains or linked rods, connected at their forward ends to levers M, and also to the frame at a point practically in the same vertical plane with the forward ends of the drag-bars, and at their rear ends connected to the longitudinally-adjustable plates K, substantially as described.

4. In a standard-bracket, the combination of the bed-plate H, the slotted slip-arm h , fitted to receive the shovel-standard, screw-bolt h'' , upon which the slip-arm works, swivel-socket g , and eyebolt g'' , whereby the shovel is allowed to turn back to pass obstructions, as hereinbefore set forth.

5. The swivel-block i' , in combination with the shield and chambered socket, substantially as herein described, to limit the oscillatory movement of the shield, as hereinbefore set forth.

6. The chambered socket secured to the drag-bar, and made adjustable thereon by means of the screw-eyebolt, as herein described, in combination with the swivel-block, secured to curved supporting-bar to limit the downward movement of the shield, as hereinbefore set forth.

7. The rosette-plates herein described, secured to the inner face and rearward-projecting ends of the converging beams, the inner plate made adjustable to raise or lower the stud projecting eccentrically from its inner face, for the purpose of raising and lowering the driver's seat, as and for the purpose hereinbefore set forth.

8. The adjustable seat-plates P, in combination with the curved bars N, pivoted at their forward ends to the frame, and the seat O, made longitudinally adjustable on the seat-bars, and arranged to turn the seat forward, substantially as set forth.

MORRIS L. UTTER.

Witnesses:

A. O. BEHEL,
JAMES FERGUSON.