

G. HAMMER,
Cork-Cutting Machine.

No. 197,514.

Patented Nov. 27, 1877.

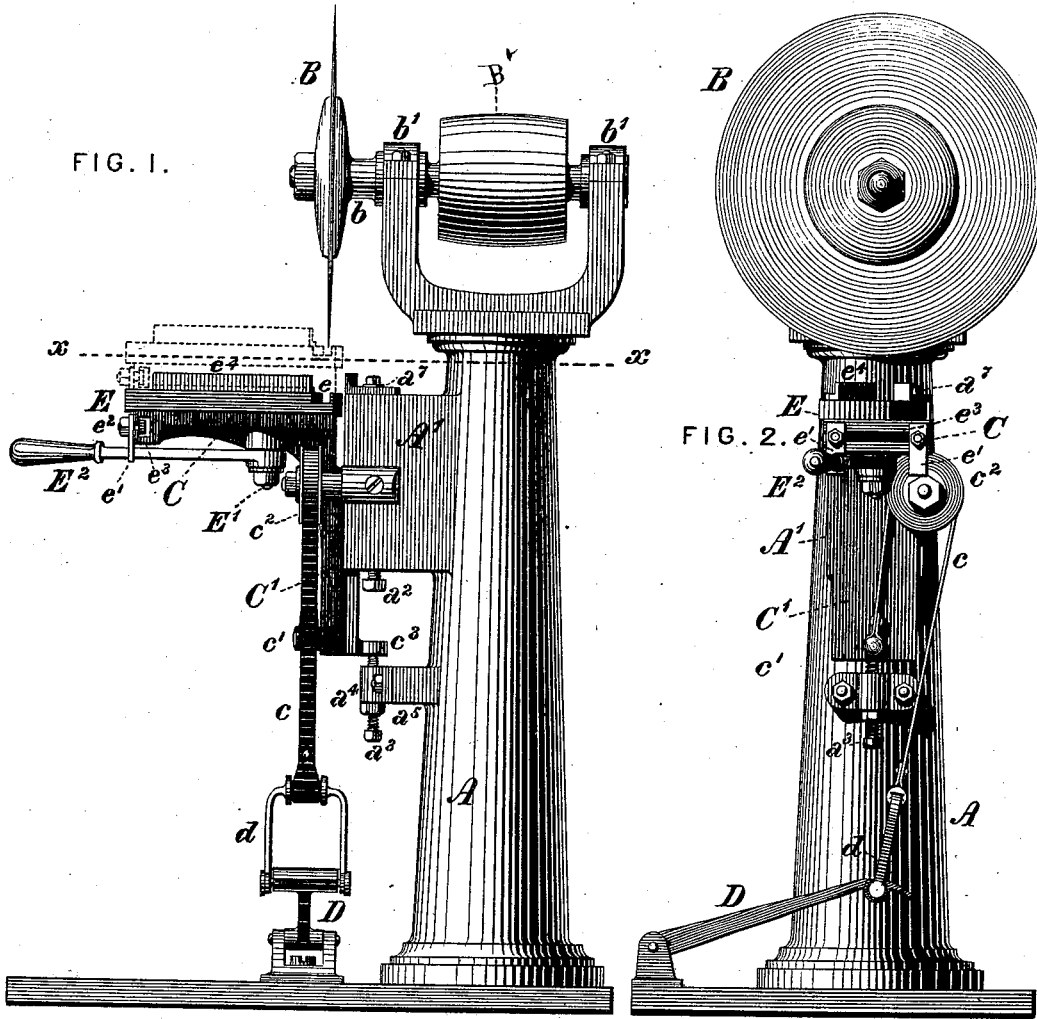
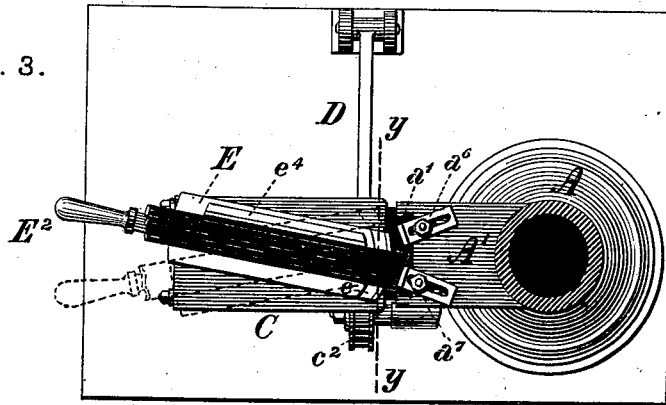

FIG. 1.

FIG. 2.

FIG. 3.



WITNESSES.

Geo. A. Vaillant.
W. A. Cheyney.

INVENTOR.

George Hammer.
By J. Thomson Bell.
att'y.

UNITED STATES PATENT OFFICE.

GEORGE HAMMER, OF REUTLINGEN, GERMANY, ASSIGNOR OF ONE-HALF HIS RIGHT TO WILLIAM RAUSCH, OF PHILADELPHIA, PENNSYLVANIA.

IMPROVEMENT IN CORK-CUTTING MACHINES.

Specification forming part of Letters Patent No. **197,514**, dated November 27, 1877; application filed October 19, 1877.

To all whom it may concern:

Be it known that I, GEORGE HAMMER, of Reutlingen, in the Empire of Germany, at present residing in the city and county of Philadelphia, and State of Pennsylvania, have invented certain new and useful Improvements in Cork-Cutting Machines, of which the following is a specification:

My improvements relate to that class of machines in which slabs or blocks of cork are subdivided by the action of a cutter into blanks designed to be subsequently worked into frusto-conoidal form, for use as stoppers in jugs, bottles, and other vessels; and my invention is designed to economize material in providing means by which the blanks may be cut so that two of their sides shall be inclined relatively to their ends at an angle corresponding with the desired taper of the finished cork, thus correspondingly reducing the amount of waste in turning or finishing the blanks.

To this end my improvements consist in combining, with a knife or cutter, a table which is movable toward and from the cutter, a rest or support pivoted to the table and adjustable thereon at different angles relatively to the line of cut, and adjustable stops which regulate the traverse of the rest and table and position of the slab, and maintain them in position during the operation of the cutter on the slab, all as hereinafter more fully set forth.

In the accompanying drawings, Figure 1 is a side view, in elevation, of a cork-cutting machine embodying my improvements; Fig. 2, a front view of the same; and Fig. 3, a horizontal section at the line *x x* of Fig. 1.

The mechanism is mounted on and supported by a vertical column, A, which may be provided with a special bed-plate, or secured directly to the floor, as desired. A circular knife or cutter, B, is secured upon a shaft, *b*, which is rotated in bearings *b'* on the top of the column A by a belt passing around the driving-pulley B'. A vertical guide, A', is formed upon or secured to the column A, and has on its outer face a dovetail groove, *a'*, within which is fitted the guide-arm C' of a horizontal table, C. The guide-arm and attached table are movable vertically toward and from the cutter-shaft, in this instance by means of a strap, *c*, which is

secured at one end to a pin, *c'*, on the lower portion of the guide-arm C', and, passing around a pulley, *c''*, on the guide A', is connected to the stirrup *d* of a treadle, D, pivoted to the floor or bed-plate. The vertical traverse of the table C is regulated by set-screws *a''* and *a'''*, which are, respectively, tapped into the bottom of the guide A' and into a nut, *a'''*, bolted to a lug, *a''''*, on the column A, below the guide A'. A dog, *c'''*, on the inner side of the guide-arm C', abuts against the set-screws *a''* and *a'''* to limit the upward and downward movement of the table, which, by proper adjustments of said set-screws, may be varied and regulated as required in the operation of the machine.

A rest or support, E, for the slabs of cork to be cut is pivoted upon the upper surface of the table C by a pin or bolt, E¹, passing through a socket in the table, and having a horizontal hand-lever, E², below the same. A segmental groove, *e*, is formed in the upper surface of the support E, at the inner end thereof, the radius of the center line of the groove being equal to the horizontal distance between the centers of the cutter B and the pivot-bolt E¹ of the support. The degree of traverse of the support E' relatively to the axial line of the cutter is regulated and limited by stops *e'*, which project below the table C, so as to serve as abutments for the hand-lever E², and are adjusted and held in position by nuts *e''* on bolts which fit in a slot, *e'''*, in the outer face of the table. A longitudinal bearing or guide piece, *e''''*, is secured upon the support E, against which the side of the slab of cork rests while being cut, and the end of the slab abuts against one or the other of two stops, *a^b a^c*, which are secured to and adjustable at desired angles upon the top of the guide A' by slots and set-screws.

In the operation of the machine, the stops *e'*, *e''*, *a^b*, and *a^c* are adjusted and secured in position, so that when the hand-lever E² abuts against one of the stops *e'* the line of cut will be at the desired angle, with the sides of the slab resting on the support against the bearing *e''* and stop *a^c*, as shown in Fig. 3, in which the slab is represented in heavy black lines, and the line of cut by the dotted line *yy*. The table is then elevated by the treadle, and a blank cut from the slab, the groove *e* enabling

the cutter to pass entirely through the slab without coming in contact with the support. The table being then lowered, the support is moved by the hand-lever until the latter abuts against the stop e^1 on the opposite side, and the end of the slab being moved up to and resting against the stop a^6 , the table is again elevated, and another blank cut from the slab, and so on, until the slab is exhausted, the successive divisions being made, as shown, at the same inclination or angle with the sides of the slab, and alternately reversed in direction.

It is obvious that the table and support might be raised and lowered by a hand-lever, if desired; but the treadle, as shown, is preferable, for the reason that it leaves the hands of the operator free for the management of the support and slab.

Wear of the knife and support and variation in thickness of the slabs operated on may

be compensated by proper adjustments of the set-screws a^2 and a^3 , by which the movements of the table are regulated.

I claim as my invention and desire to secure by Letters Patent—

1. The combination, in a cork-cutting machine, of a cutter, a table movable toward and from the same, and a cork-support pivoted upon the table, and adjustable at desired inclinations relatively to the line of cut, substantially as set forth.

2. The combination of the stationary guide, the sliding table, the pivoted cork-support and its hand-lever, and adjustable stops, secured, respectively, upon the table and the guide, substantially as set forth.

GEORGE HAMMER.

Witnesses:

J. SNOWDEN BELL,
THEODORE BERGNER.