

W. BROWN.
 Machine for Splitting and Flaring Hoop-Iron.
 No. 197,596. Patented Nov. 27, 1877.

FIG. 1.

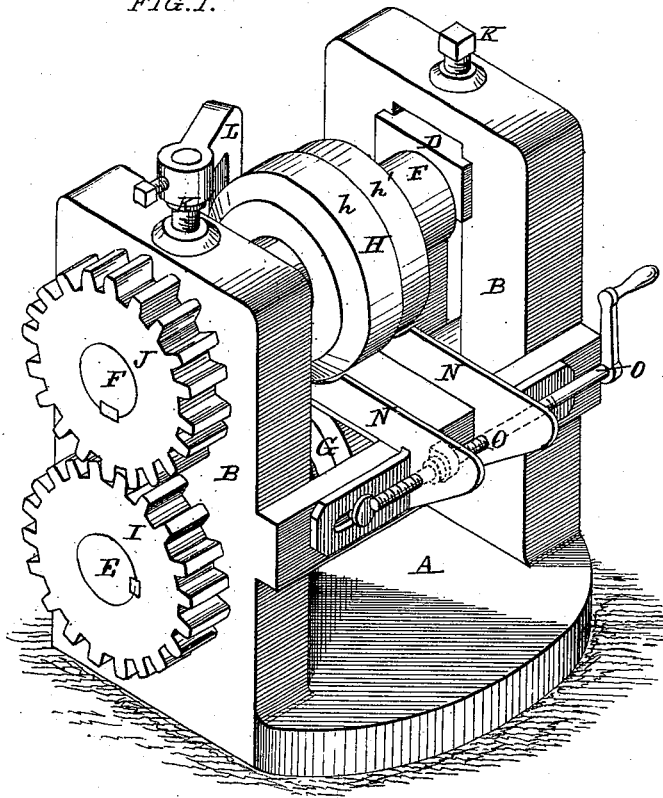
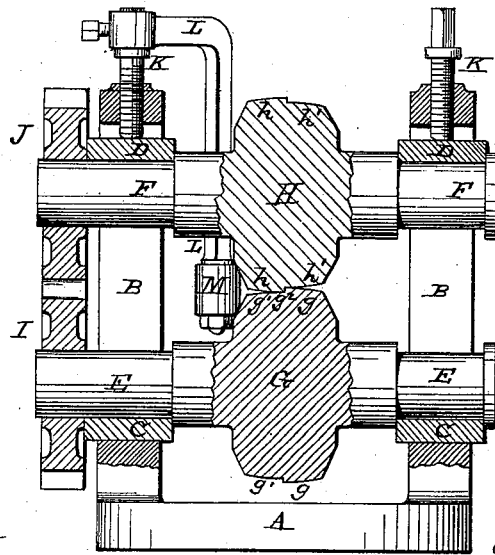

FIG. 2.



ATTEST:
 Geo. H. Knight
 Chas. J. Gooch

INVENTOR:
 William Brown
 By *Wm. H. Knight*

UNITED STATES PATENT OFFICE.

WILLIAM BROWN, OF ST. LOUIS, MISSOURI.

IMPROVEMENT IN MACHINES FOR SPLITTING AND FLARING HOOP-IRON.

Specification forming part of Letters Patent No. **197,596**, dated November 26, 1877; application filed October 24, 1877.

To all whom it may concern:

Be it known that I, WILLIAM BROWN, of the city of St. Louis, in the State of Missouri, have invented a certain new and useful Improvement in Machines for Splitting and Flaring Hoop-Iron, of which the following is a full, clear, and exact description, reference being had to the accompanying drawings, making part of this specification.

My improvement consists in combining, with rolling shears, beveled rollers, that expand one edge of the split hoop-iron, so as to give to the hoops made therefrom the necessary flaring form.

My improvement also relates to an automatic device for relieving the roller-pressure upon the hoop-iron when it is too great, so as to impart too great a curvature. This device consists of an arm which extends down from a set-screw bearing upon a box of the upper roller-shaft to a position where the outer edge of the hoop comes in contact with it, (said arm.) When too great a curvature is given to the hoop-iron it moves the arm outward, and turns up the set-screw, so as to relieve the roller-pressure.

In the drawings, Figure 1 is a perspective view of the machine, and Fig. 2 a vertical section in the plane of the roller-shaft.

A is the bed-plate. B B are standards, supporting the boxes C C and D D of the shafts E F, carrying the rollers G and H. These shafts E F carry spur-wheels I and J, engaging together, so as to insure synchronous motion in the rollers.

Power may be applied to drive the machine through the spur-wheel I, or otherwise.

Each of the rollers has a part of its periphery of greater diameter than the other part, and the parts of the larger diameter g and h are matched with the parts of smaller diameter, h' and g' , of the other rollers, respectively, and thus a rolling or rotating cutter is formed by the angular edge or corner g^2 , extending around both rollers, and the hoop-iron is split as it is fed in endwise.

The rolling surfaces g g' and h h' are beveled, as shown, the sides of the surfaces at the cutter g^2 having a diameter greater than that at the outer sides of such surfaces, so that it will be seen the inner edges of the hoops, after splitting, will be compressed. This imparts to the hoop-iron a curve in the plane of its width,

so that when made up into hoops the hoops have the required flaring form.

The boxes D D are movable vertically, and are held down by set-screws K, so as to make the rolling-pressure adjustable, (by turning the set-screws.)

To one or both of the set-screws is attached a bent arm, L, which extends down so that its lower end is in the course of the hoop upon that side when it leaves the rollers, being in such position that when the hoop has too great roller-pressure, and, consequently, too great a curve imparted to it, it will move the arm outward and turn up the set-screw K, so as to relieve the roller-pressure and decrease the curvature of the hoop-iron.

At the point of contact of the hoop-iron with the arm, the arm carries an anti-friction roller, M.

The machine is calculated for splitting hoop-iron of various widths.

N N are feed-guides, whose distance apart corresponds with the width of the hoop-iron being fed into the machine. The guides may be adjusted in distance asunder by a right-and-left-hand screw, O, passing through them, or by other means.

Among the advantages of my machine I will mention two: First, as the narrower widths of hoop-iron are much higher in price per pound than the wider, I am able to use a cheaper article in the production of hoops for small work, such as kegs and buckets, &c., and which, owing to the second advantage I shall name, will be seen to be better as well as cheaper.

The second advantage is, that the compression of the iron to form the flare of the hoop is made upon the split edge, which is whole and solid, whereas the outer edge is more or less ragged from imperfection in rolling.

I claim as my invention—

1. The combination, in the rollers G and H, of the shears g^2 and beveled surfaces g g' h h' , substantially as and for the purpose set forth.

2. The combination, with the set or temper screw K, of the arm L and beveled rollers G H, operating substantially as set forth.

WM. BROWN.

Witnesses:

SAML. KNIGHT,
GEO. H. KNIGHT.